



REV	CHANGE NUMBER	DATE
A	ECOWHT6844	10/14/10

- NOTES:
1. SYMBOL  INDICATES CENTER OF BALANCE.
  2. SYMBOL  INDICATES MOUNTING POINT, M10 THREADED HOLE.
  3. SYMBOL  INDICATES MOUNTING POINT, M10 THREADED HOLE FOR OMNIMOUNT 120.0 SERIES.
  4. WEIGHT APPROX. 25.2 kg [55.6 lb]
  5. SHIPPING WEIGHT APPROX. 28.2 kg [62.2 lb]

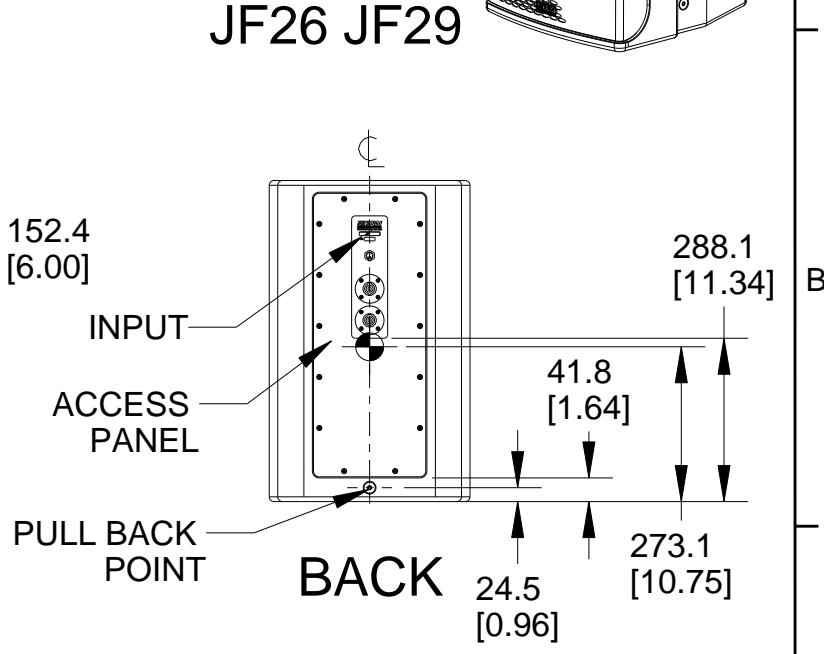
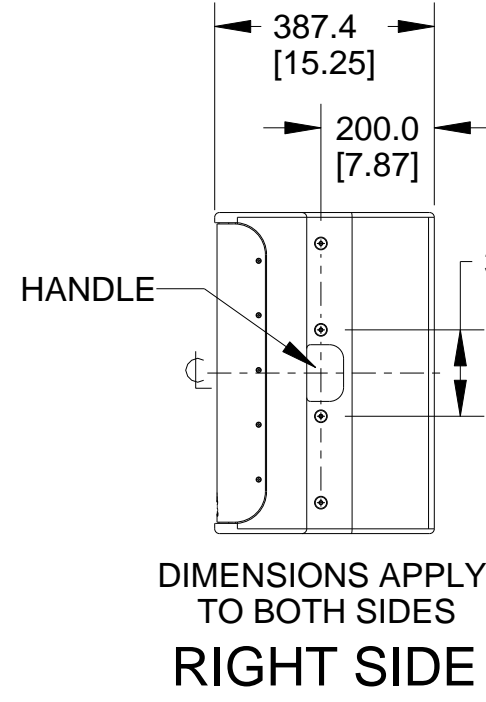
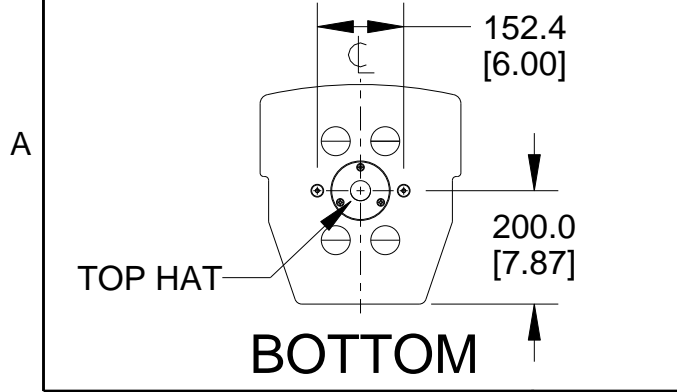
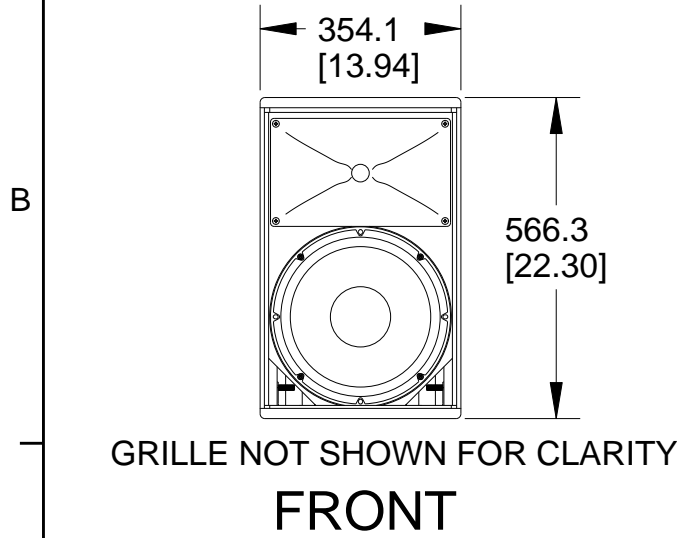
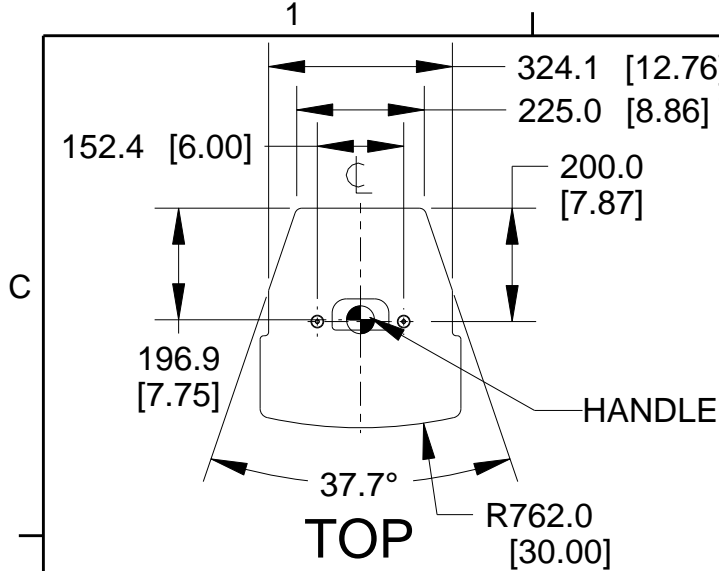
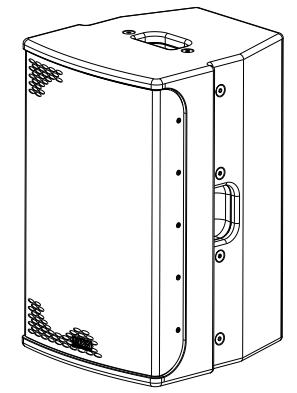
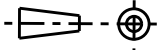

<p>THIRD ANGLE PROJECTION</p> 	<p>UNLESS OTHERWISE SPECIFIED: ALL DIMENSIONS ARE IN MILLIMETERS DUAL [INCHES] DIMENSIONS FOR REF ONLY</p>	<p><b>EAW</b> www.eaw.com</p>
	<p>TOLERANCE IN MILLIMETERS LINEAR ± 3.3 mm / ± 0.13 in ANGLES ± 1°</p>	
<p>THE INFORMATION CONTAINED HEREIN IS PROPRIETARY AND CONFIDENTIAL PROPERTY OF LOUD TECHNOLOGIES, INC. ALL RIGHTS RESERVED</p>	<p>(X.XX) = REF DIMS NO TOLERANCE IMPLIED</p>	<p><b>A</b> SHEET 1 OF 1 SCALE: 0.075</p>
	<p>TSC = THEORETICAL SHARP CORNER</p>	<p>DIMENSIONS ACROSS CENTERLINES TO BE SYMMETRICAL</p>