

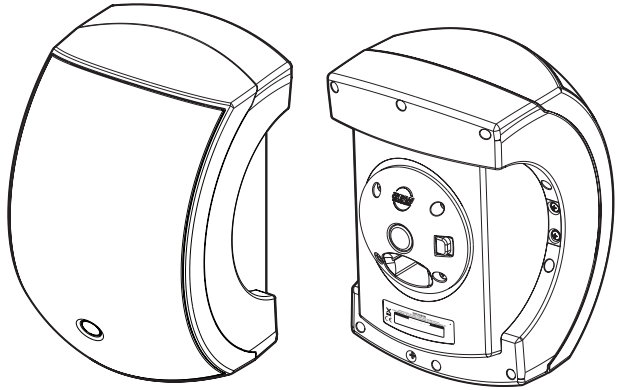

# SMS2124 SMS2990

Compact Two-Way Loudspeakers



INSTRUCTION MANUAL

# 1. SAFETY INSTRUCTIONS

1. Read these instructions.
2. Keep these instructions.
3. Heed all warnings.
4. Follow all instructions.
5. Do not use this apparatus near water.
6. Clean only with a dry cloth.
7. Do not block any ventilation openings. Install in accordance with the manufacturer's instructions.
8. Do not install near any heat sources such as radiators, heat registers, stoves, or other apparatus (including amplifiers) that produce heat.
9. Only use attachments/accessories specified by the manufacturer.
10. Refer all servicing to qualified service personnel. Servicing is required when the apparatus has been damaged in any way, such as liquid has been spilled or objects have fallen into the apparatus, the apparatus has been exposed to rain or moisture, does not operate normally, or has been dropped.
11. The entire sound system must be designed in compliance with the current standards and laws regarding electrical systems.
12. When installing and using this apparatus, keep in mind the technical specifications indicated in the dedicated section of the manual.
13. Exposure to high sound levels can cause permanent hearing loss. The sound pressure level which leads to hearing loss varies considerably from one person to another, and depends on the duration of exposure. The U.S. Government's Occupational Safety and Health Administration (OSHA) has established the maximum sound pressure levels that can be with stood without causing damage, which are shown in the table below. According to the OSHA regulations, any exposure over the maximum limits indicated in the table can reduce the hearing capacity of a person. To prevent potentially dangerous exposure to high sound pressure levels, anyone subjected to such levels must use suitable protection. When a EAW Commercial product capable of producing high sound levels is being used, it is therefore necessary to wear ear plugs or protective earphones when the limits shown in the table are exceeded. Consult the specifications provided in the instruction manual to know the maximum sound pressure (SPL) the loudspeaker is capable of producing.



The exclamation point within an equilateral triangle is intended to alert the user of the presence of important operating and maintenance (servicing) instructions in the literature accompanying the apparatus.



**WARNING!** *This equipment has been designed to be installed by qualified professionals only! There are many factors to be considered when installing professional sound reinforcement systems, including mechanical and electrical considerations, as well as acoustic coverage and performance. EAW Commercial strongly recommends that this equipment be installed only by a professional sound installer or contractor.*

Duration per day (hours)	Sound level (dBA)	Typical example
8	90	Duo in a small club
6	92	
4	95	Subway train
3	97	
2	100	Very loud classical music
1.5	102	
1	105	Locomotive at 50 feet
0.5	110	
0.25 or less	115	Loudest parts at a rock concert

Part No. 0018446 Rev. A 04/2008

© 2008 LOUD Technologies Inc. All Rights Reserved.

Printed in China.

14. Rigging Precautions: When mounting or suspending EAW Commercial loudspeaker enclosures, it is essential that load ratings, rigging techniques, and special safety considerations be appropriate for the installation. Use only the mounting/rigging points on the loudspeaker enclosure intended for this purpose. The user must determine the load requirements, dynamic loading, and any other contributing factors affecting the loudspeaker installation. The user must determine the proper design factor for specific applications and the required load rating of the connection to structure. Comply with all applicable federal, state, and local regulations.

EAW Commercial strongly recommends the following rigging system practices:

- Documentation: Thoroughly document the mounting/rigging design with detailed drawings and parts lists.
- Analysis: Have a licensed structural engineer or other qualified professional review and approve the mounting/rigging design before its implementation.
- Installation: Use personnel experienced and qualified for mounting/rigging loudspeakers in accordance with and in compliance with all federal, state and local regulations.



**DANGER:** Loudspeakers should be mounted or suspended only by persons with knowledge of the proper hardware and rigging techniques. Failure to follow these precautions may result in damage to the equipment, personal injury, or death.

## TABLE OF CONTENTS

<b>1. SAFETY INSTRUCTIONS</b> .....	<b>2</b>
<b>2. INTRODUCTION</b> .....	<b>4</b>
<b>3. INSTALLATION</b> .....	<b>5</b>
<b>4. OPTIONAL CLIP-FIT WALL BRACKETS</b> .....	<b>10</b>
<b>5. SPECIFICATIONS</b> .....	<b>16</b>
<b>Dimensions</b> .....	<b>17</b>
<b>Performance Graphs</b> .....	<b>18</b>
<b>6. SERVICE INFORMATION</b> .....	<b>23</b>
<b>7. EAW COMMERCIAL WARRANTY</b> .....	<b>23</b>

## 2. INTRODUCTION

Congratulations on the purchase of your new EAW Commercial loudspeaker. You now own one of the finest professional audio products available – the result of exceptional engineering and meticulous craftsmanship. Please read these instructions to get the maximum performance from your new loudspeaker.

Each EAW Commercial loudspeaker is intended for professional use. The construction, components, and hardware have been designed to provide robust, reliable performance for its intended application. Please ensure that you fully understand its proper installation and operation before use.

This manual describes the SMS2990 and SMS2124 loudspeakers and the optional clip-fit mounting system. Each loudspeaker is an economical solution for exceptional fidelity in speech reinforcement and background music applications. They are especially suited for small to mid-sized spaces with excessive reverberation or problematic sound reflections. The drivers and system voicing are designed to maximize vocal range clarity and speech intelligibility, without compromising the broadband frequency response required for pleasing music reproduction. The included U bracket allows setting the enclosure's angle for wall-mounting.

Both loudspeakers have four 3 inch Kevlar woofers configured in a precise arrangement. The SMS2990 uses one 1.3" dome tweeter, and has a 90° x 90° coverage pattern. The SMS2124 uses two 2" cone tweeters, and has a 120° x 40° coverage pattern. Apart from this difference, the operation and details of the loudspeakers are identical, and this manual covers both models.

Two optional "clip-fit" mounting brackets are available that allow the loudspeaker to be easily clipped in place and adjusted within a wide range of angles. One bracket (CF-2TX) includes an internal transformer for constant voltage applications, and the other (CF-2LZ) is for constant impedance applications

### Features:

- SMS2990 has 90° horizontal x 90° vertical nominal beamwidth
- SMS2124 has 120° horizontal x 40° vertical nominal beamwidth
- Passive crossover for economical, single-amplifier operation, optimized for speech intelligibility
- Includes adjustable mounting bracket
- Optional clip-fit bracket for constant-voltage systems
- Optional clip-fit bracket for constant-impedance systems
- Five-year warranty

### Applications include:

- Meeting rooms
- Houses of worship
- Courtrooms
- Multizone paging/music systems
- Hotels
- Boardrooms
- Multi-purpose facilities

# 3. INSTALLATION

## Unpacking and Inspection

Visually inspect the outside of the shipping carton and check for any damage. After unpacking, if you find concealed damage to the loudspeaker, save the packing materials for the carrier's inspection, notify the carrier immediately, and file a shipping damage claim. Although EAW Commercial will help in any way possible, it is always the responsibility of the receiving party to file any shipping damage claim. The carrier will help prepare and file this claim.

## Mounting Precautions

The mounting bracket provided can be used for wall mounting the loudspeaker.



**WARNING:** Installation should only be done by an experienced technician.

Improper installation may result in damage to the equipment, injury or death. Make sure that the loudspeaker is installed in a stable and secure way in order to avoid any conditions that may be dangerous for persons or structures:

- Check to make sure that the support surface (e.g., wall, etc.) has the necessary mechanical characteristics to support the weight of the loudspeaker without the danger of it falling.
- Always use support elements suitable for the material of the wall that will support the loudspeaker (e.g., screw anchors for bricks, screw anchors for cement, etc.). Due to various construction methods and materials used today, the hardware for securing the bracket to the mounting surface is not supplied. Consult a building professional for the proper mounting hardware before mounting the bracket.
- Before mounting the loudspeaker, carefully check all the components to be used to make sure there is no damage, deformation, corrosion and/or missing or damaged parts that could reduce the safety of the installation.
- Consult a professional rigger or structural engineer prior to mounting loudspeakers from a structure not intended for that use. Always know the working load limit of the structure supporting the loudspeaker. Always make sure that the rigging hardware minimum rating is at least five times the actual load.
- Avoid installing the loudspeaker in places exposed to harsh weather conditions.

## Wall bracket mounting instructions

Follow these instructions to mount the loudspeaker using the supplied wall mount bracket.



Warning: Installation should only be done by an experienced technician. Improper installation may result in damage to the equipment, injury or death.

1. Mounting the wall bracket to the wall:

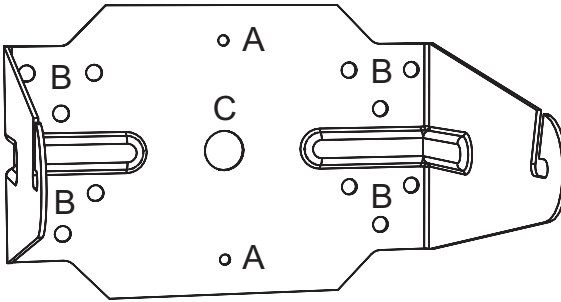

Horizontal mounting

- a. Mount the bracket so the slots in the ends are upwards as shown. This will support the loudspeaker even if the clamp nuts become loose.

When mounted on a wall, the bracket should be centered over a J-box that is appropriately rated and installed for the weight of the speaker and bracket. The provided 6-32 screws should be inserted through two holes labeled "A" as shown. In addition, the holes labeled "B" should be used to attach the bracket to a wall stud with user-supplied hardware. Wiring from the J-box can pass through the large center hole "C."

- b. The wall bracket can also be mounted sideways on a vertical wall, or mounted on a ceiling. Make sure that you consult a rigging professional to examine the wall or ceiling and determine the proper hardware for mounting the bracket safely and securely.

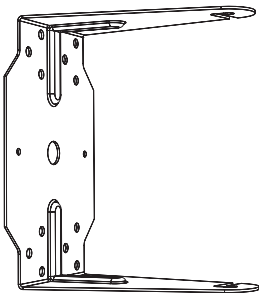

Side mounting

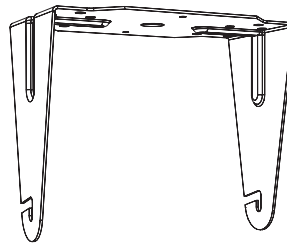

Ceiling mounting

## 2. Mounting the loudspeaker to the wall bracket:

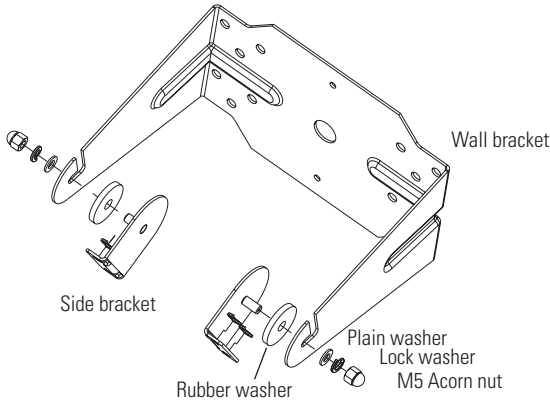

- a. On each side of the loudspeaker, undo two screws as shown. Remove the small trim pieces and keep them safe.

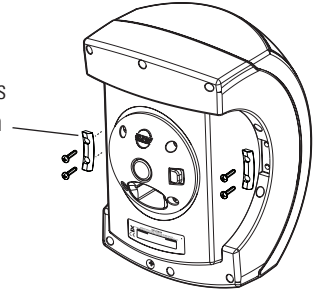

- b. Use the same screws, and the lock washers provided in the accessories box, to attach a side bracket to each side of the loudspeaker.

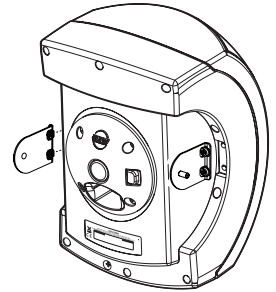

- c. Fit a large rubber washer on each side bracket and fit this assembly onto the wall bracket. Add the plain washer, lock washer, and acorn nut and hand-tighten.
- d. Adjust the loudspeaker to the desired angle, and secure the acorn nuts. These are M5 size.

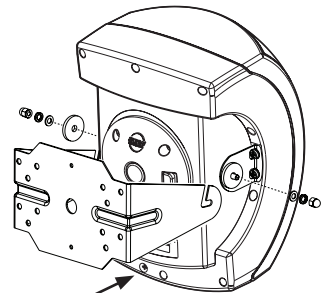

## Tethering the loudspeaker:

An M5 threaded hole in the bottom rear of the loudspeaker is provided for tethering the loudspeaker. This will reduce the chance of it from falling during structural events such as earthquakes or fires. Professional installers will be able to advise the best tethering system for your installation.

# Electrical Installation



**Note:** Observe all local and national codes when installing the loudspeaker.

All connections must be made with the power amplifier turned off.

The following example of a low-impedance connection uses a EAW Commercial CAZ800 amplifier. This amplifier uses a screw-terminal output.

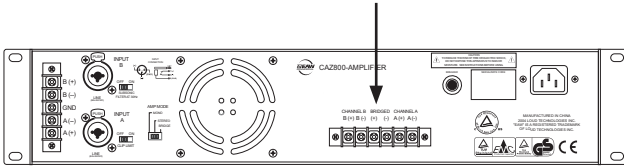

1. Connect the A + terminal on the amplifier to the (+) screw terminal of the input connector as shown.
2. Connect the A – terminal on the amplifier to the (–) screw terminal of the input connector.

CHANNEL B BRIDGED CHANNEL A  
B (+) B (-) (+) (-) A (+) A (-)

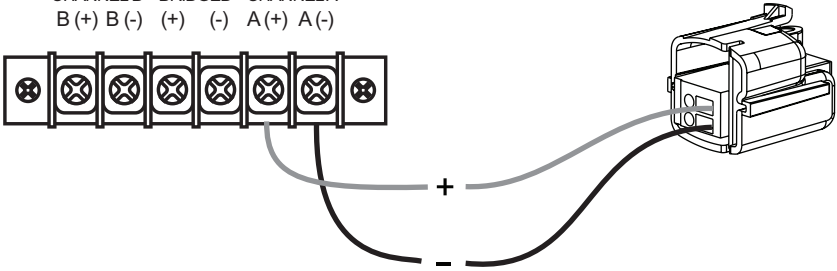

The loudspeakers have a nominal impedance of 8 ohms. If you connect other loudspeakers in parallel, make sure that the overall impedance does not drop below the minimum required by your power amplifier.

3. Plug the input connector into the back of the loudspeaker, until it clicks securely in place.

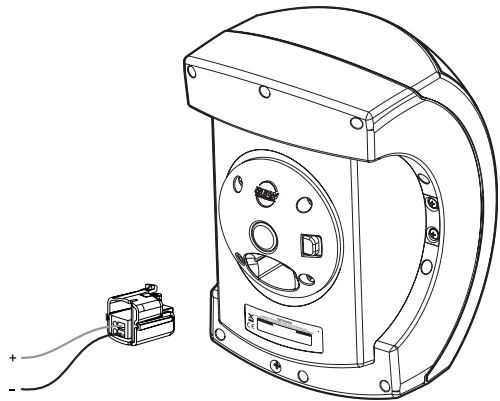



4. Disconnecting the input connector:

- a. Slide the red plastic tab towards the center of the loudspeaker, and hold it there while you press the red center button inwards. The input connector can then be removed.

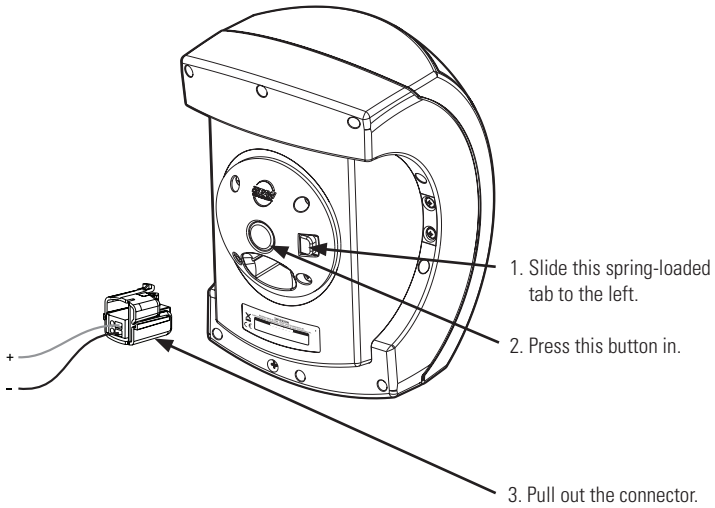

## 4. OPTIONAL CLIP-FIT WALL BRACKETS

Follow these instructions to mount the loudspeaker using the optional clip-fit wall mount brackets CF-2TX and CF-2LZ.



**Warning:** Installation should only be done by an experienced technician. Improper installation may result in damage to the equipment, injury or death.

### Overview

These optional brackets allow the loudspeaker to be mounted to the wall and electrically connected at the same time. They also allow you to wire all the brackets in your system, and add the loudspeakers at a later time.

Once the bracket has been wired and mounted to the wall, the loudspeaker can be quickly pressed onto the input connector and held securely in place. It can be easily adjusted in vertical and horizontal angle, and locked in place with a locking wheel.

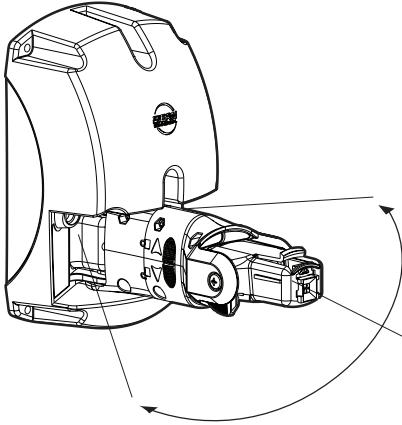

Horizontal adjustment

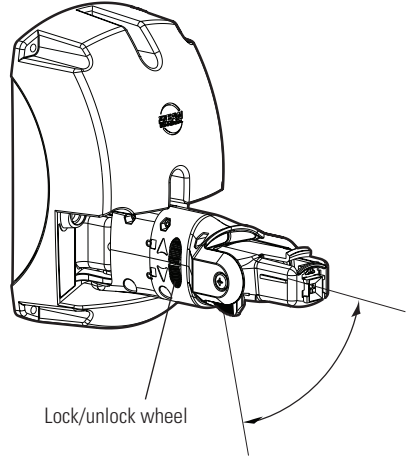

Vertical adjustment

Two brackets are available:

- The CF-2TX includes an internal transformer for constant voltage applications. The transformer has multiple taps, with a selector switch that allows you to set the desired power tap wattage for your system.
- The CF-2LZ is used for constant impedance applications, with no internal power transformer.
- Each bracket comes with two wire crimps, used for connecting the two bracket wires to your system wiring.

The mounting details are identical for each clip-fit bracket.

# CF-2TX Electrical Installation

Before the clip-fit bracket is mounted to the wall, the electrical connections to your system should be made. Two wire crimps are included to make the connections.

**⚠ Note:** Observe all local and national codes when installing the CF-2TX. All connections must be made with the power amplifier turned off.

The following examples of 70 V and 100 V connections show an EAW Commercial CAM160, a typical mixer/amplifier. Its speaker-level output is a screw terminal strip, with outputs for 25 V, 70 V, 100 V, ground, and 4 ohm.

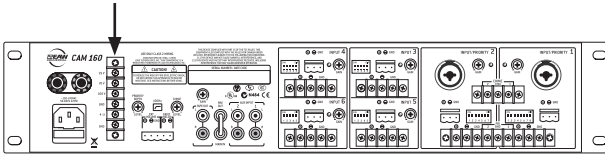

## 70 V connection example

1. Connect the amplifier's 70 V terminal to the red (+) input wire on the CF-2TX.
2. Connect the amplifier's GND terminal to the black (-) input wire on the CF-2TX.

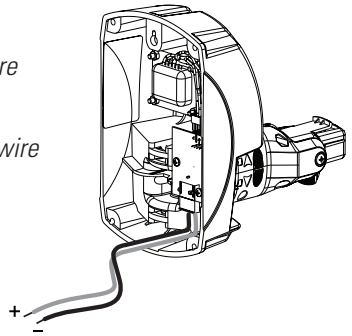
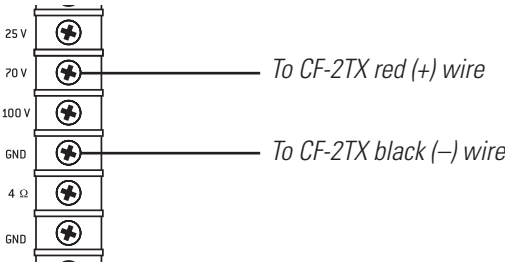

3. Select the power tap as shown on the next page.

## 100 V connection example

1. Connect the amplifier's 100 V terminal to the red (+) input wire on the CF-2TX.
2. Connect the amplifier's GND terminal to the black (-) input wire on the CF-2TX.

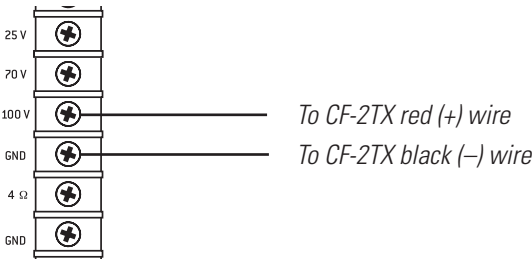

3. Select the power tap as shown on the next page.



## Selecting the power tap (CF-2TX only):

 Make sure the power amplifier is turned off when adjusting the power taps or making connections.

1. Select the desired power tap by turning the switch with a flat-ended screwdriver.

If you are using a 70 V system, the wattage ratings are: 8, 16, 32 and 64 W.

If you are using a 100 V system, the available wattage ratings are: 16, 32, and 64 W.

 Make sure that you do not overload the amplifier. This may cause overheating to the amplifier, and possible damage to your loudspeakers. To avoid overloading, make sure that the selected taps on the loudspeakers add up to no more than 80% of the rated power of the amplifier being used.

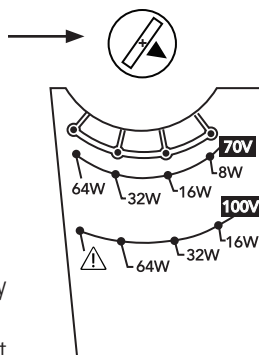

## CF-2LZ Electrical Installation

 **Note:** Observe all local and national codes when installing the CF-2LZ clip-fit bracket. All connections to the loudspeaker must be made with the power amplifier turned off. Two wire crimps are included to make the connections.

The following example of a low-impedance connection uses a EAW Commercial CAZ800 amplifier. This amplifier uses a screw-terminal output.

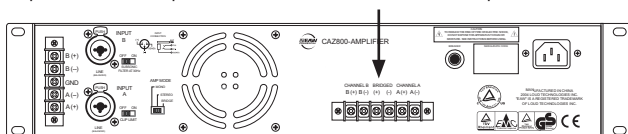

1. Connect the A + terminal on the amplifier to the red (+) input wire on the CF-2LZ.
2. Connect the A – terminal on the amplifier to the black (-) input wire on the CF-2LZ.

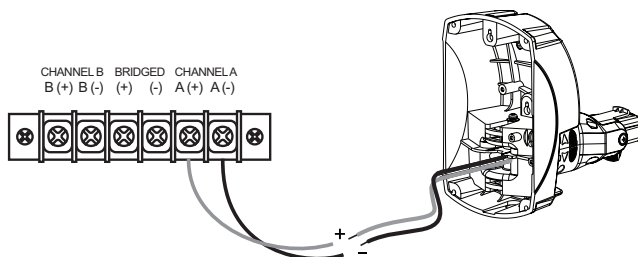

 The loudspeakers have a nominal impedance of 8 ohm. If you connect other loudspeakers in parallel, make sure that the overall impedance does not drop below the minimum required by your power amplifier.

## Mechanical Installation

### Mounting the clip-fit brackets to the wall:

- a. Mount the wall bracket to the desired surface, in this vertical orientation only. Note that the bracket has two mounting keyholes with vertical spacing that allows them to be used with a standard wall J-box.

Two screws are supplied for securing the wall bracket to a J-box. Install the shorter 6-32 screw in the top hole of the J-box, and the longer screw in the bottom. Only screw them in by a few threads initially, then place the clip-fit bracket over the screws through the key-hole slots in the bracket as shown. Tighten the screws once the bracket is securely in place.

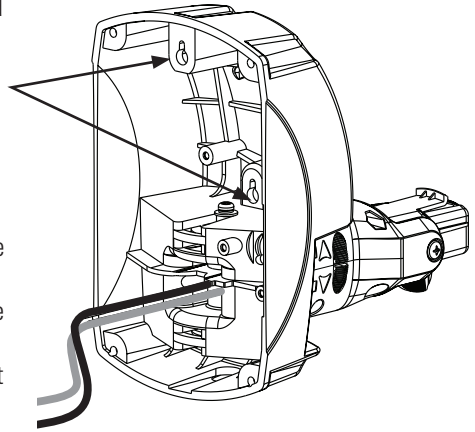

- b. In addition to securing the bracket to a J-box, secure it to a structural wall stud with user-supplied hardware. The spacing of the four corner holes is designed to align with structural studs on either side of the single-position J-box.

### Rotating the loudspeaker's input section (if required):

The loudspeaker can be mounted vertically (as shown) onto the clip-fit bracket, or horizontally. If you want to change the orientation, follow these steps:

- a. Remove the four screws holding the circular input section in place.
- b. Pull out the input section by approximately half an inch, and rotate it through no more than 90 degrees.
- c. Secure the input section into its new position with the four screws.

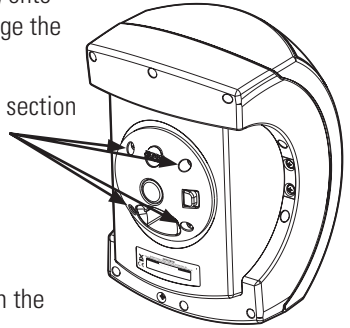

## Mounting the loudspeaker onto a clip-fit bracket:

- a. Once the clip-fit bracket has been wired and secured to the wall, press the loudspeaker onto the input connector, until it clicks in place.



Make sure it is fitted on correctly and clicks in place securely.

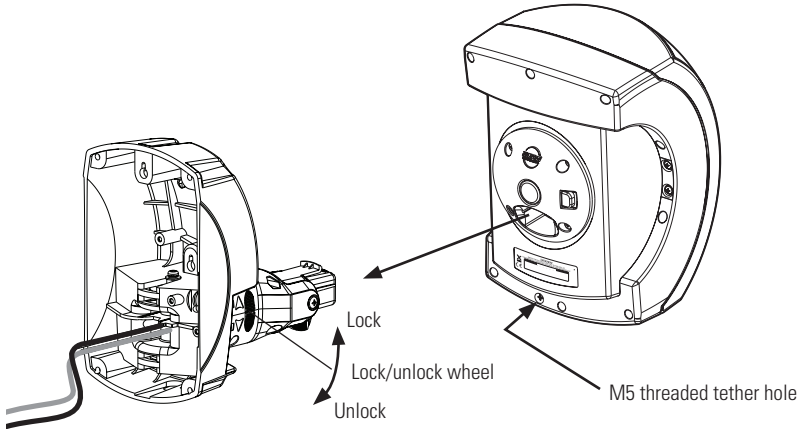

## Tethering the loudspeaker:

An M5 threaded hole in the bottom rear of the loudspeaker is provided for tethering the loudspeaker. This will reduce the chance of it from falling during structural events such as earthquakes or fires. Professional installers will be able to advise the best tethering system for your installation.

## Adjusting the loudspeaker angle:

The adjustment and locking mechanism has been designed to be easy to use.

- a. Rotate the locking wheel until the loudspeaker can be rotated horizontally and vertically. Find the desired loudspeaker position, and then rotate the locking wheel until it locks this position. Slots are provided in the locking wheel to allow further tightening with a flathead screwdriver if required.
- b. Perform a listening test to verify that the coverage is acceptable.

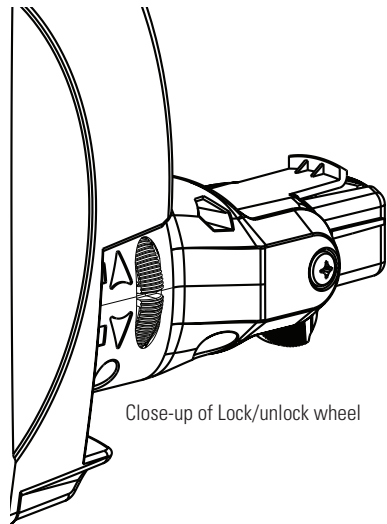

## Unmounting the loudspeaker from the bracket:

- a. Slide the red plastic tab towards the center of the loudspeaker, and hold it there while you press the red center button inwards. Pull the loudspeaker off the bracket.

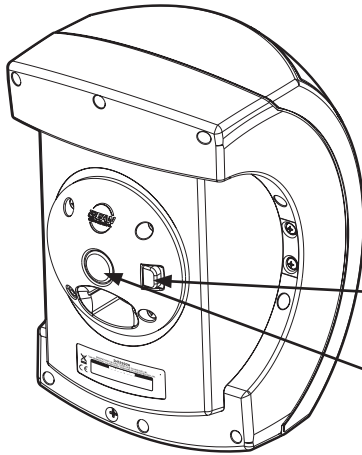

1. Slide this red spring-loaded tab to the left and hold it there.

2. Press this button in and pull off the loudspeaker from the bracket.

## Clip-fit bracket dimensions:

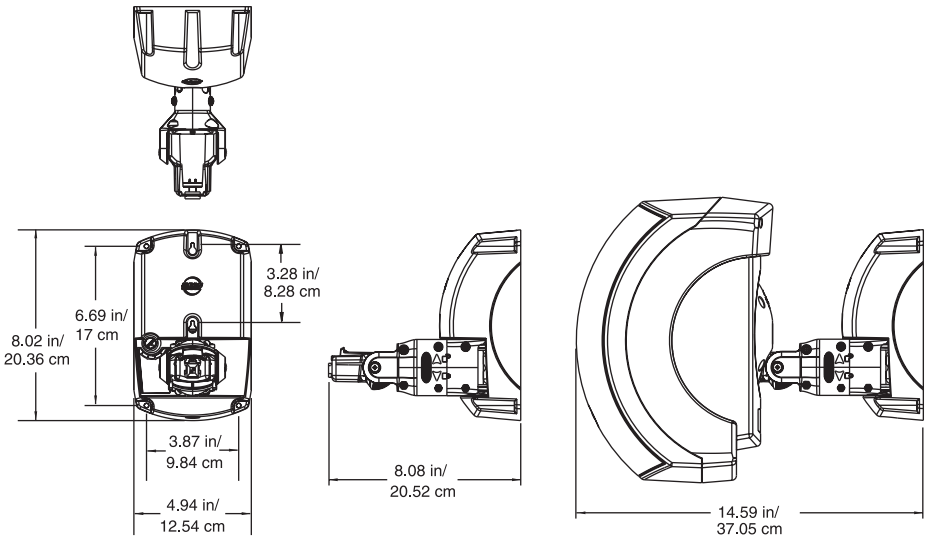

# 5. SPECIFICATIONS

Model:	SMS2124	SMS2990
Woofers	3 in x 4 cone	3 in x 4 cone
Woofers Loading	Vented	Vented
Tweeters	2 in x 2 cone	1.3 in x 1 dome
Tweeters Loading	Horn-loaded	Horn-loaded
Operating Range (-10 dB)	93 Hz - 20 kHz	90 Hz - 20 kHz
Horizontal Beamwidth - Nominal	120 degrees	90 degrees
Vertical Beamwidth - Nominal	40 degrees	90 degrees
Axial Sensitivity (whole space SPL)	90 dB, 93 Hz - 20 kHz	90 dB, 90 Hz - 20 kHz
Input Impedance - Nominal	8 ohm	8 ohm
Input Impedance - Minimum	6.4 ohm @ 321 Hz	6.5 ohm @ 325 Hz
Recommended High Pass Filter	≥ 90 Hz, 24 dB/octave Butterworth	≥ 90 Hz, 24 dB/octave Butterworth
Power Handling	125 W, 32 V @ 8 ohm	125 W, 32 V @ 8 ohm
Power taps 70 V (with CF-2TX optional mounting bracket/transformer)	64 W, 32 W, 16 W, and 8 W	64 W, 32 W, 16 W, and 8 W
Power taps 100 V (with CF-2TX optional mounting bracket/transformer)	64 W, 32 W, and 16 W	64 W, 32 W, and 16 W
Maximum SPL, Average	111 dB	111 dB
Maximum SPL, Peak	117 dB	117 dB
Height	12.00 in/ 30.48 cm	12.00 in/ 30.48 cm
Width	7.62 in/ 19.35 cm	7.62 in/ 19.35 cm
Depth	8.26in/ 20.98 cm	8.26in/ 20.98 cm
Dimension Tolerance	± 0.1 in/0.25 cm	± 0.1 in/0.25 cm
Weight	6.2 lb/ 2.8 kg	8.0 lb/ 3.6 kg

## Disclaimer

EAW Commercial continually engages in research related to product improvement, new materials, and production methods. Design refinements are introduced into existing products without notice as a routine expression of that philosophy. For this reason, any current EAW Commercial product may differ in some respect from its published description, but will always equal or exceed the original design specifications unless otherwise stated.

“EAW Commercial” is a trademark of LOUD Technologies Inc.

All other brand names mentioned are trademarks or registered trademarks of their respective holders, and are hereby acknowledged.



# Dimensions

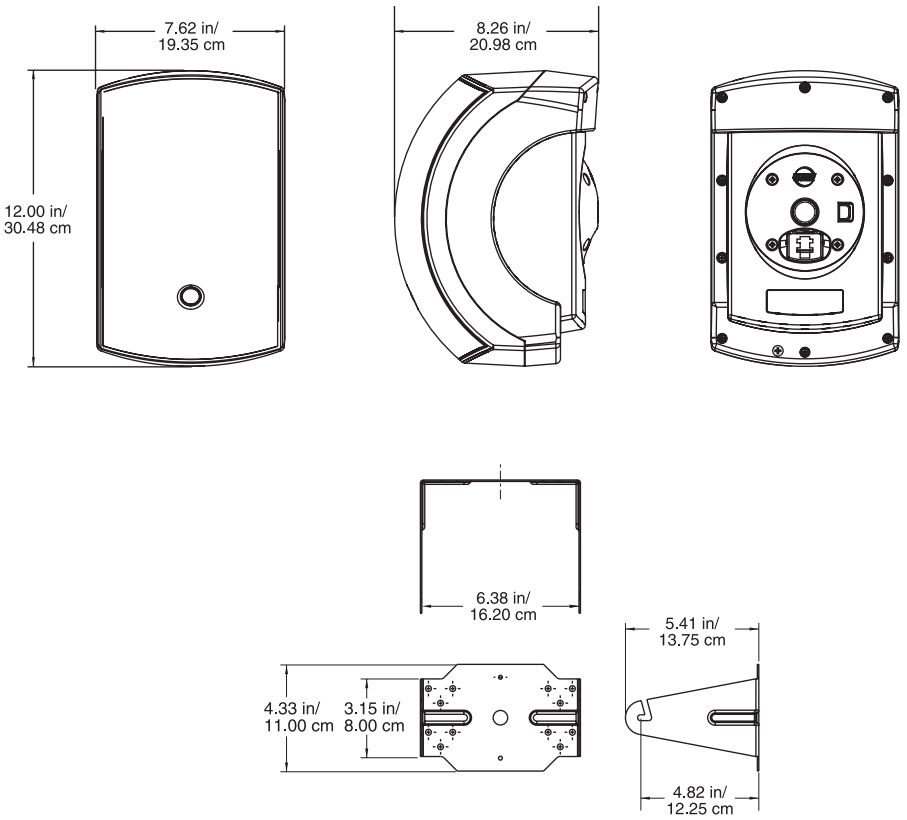

## Mounting Bracket (supplied)

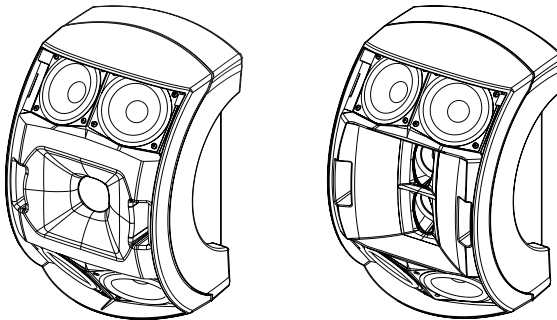

**SMS2990**

**SMS2124**

These views show the differences between the two models in the tweeter section. Note that the grill is not removable.



# Performance Graphs

## Impedance vs Frequency

### SMS2124

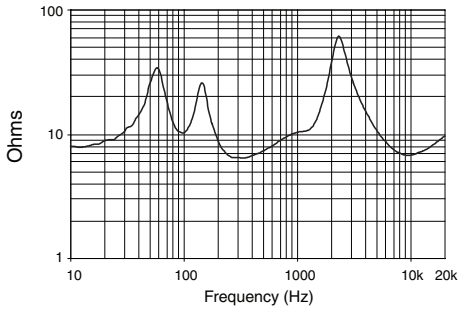

### SMS2990

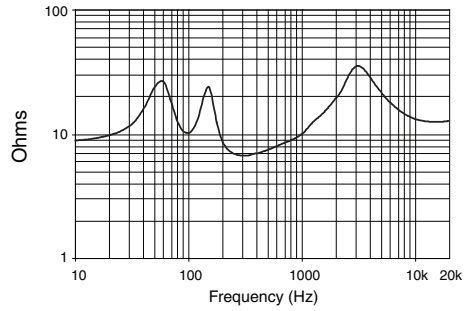

## Axial Response vs Frequency

### SMS2124

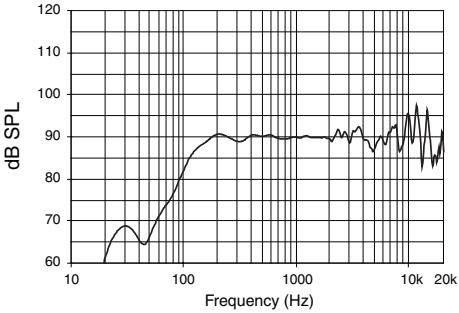

### SMS2990

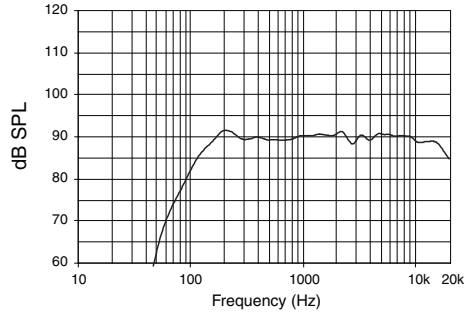

## Beamwidth vs Frequency

### SMS2124

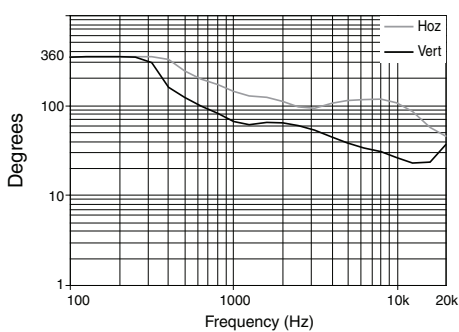

### SMS2990

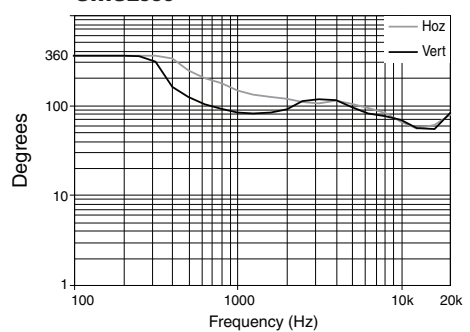

# SMS2124 Vertical Polar Diagrams

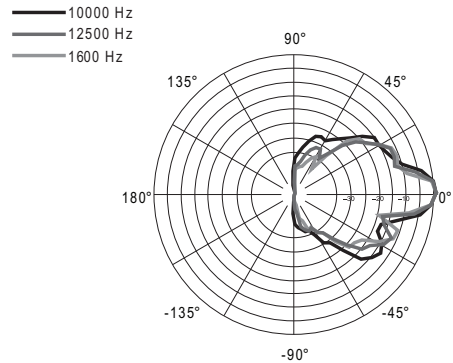
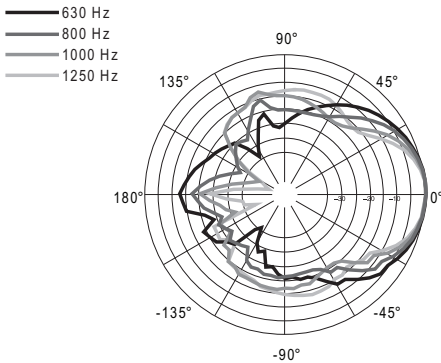
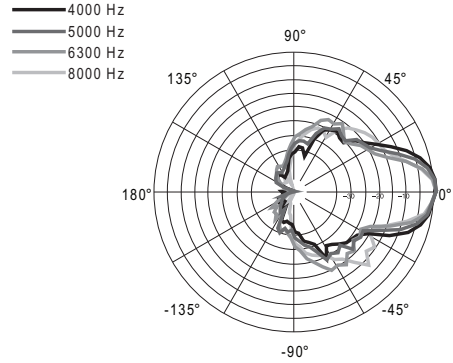
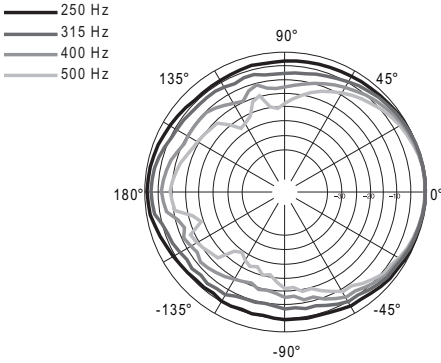
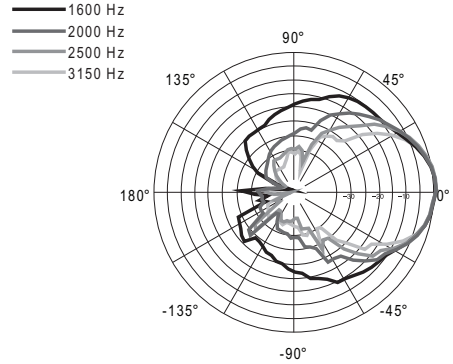
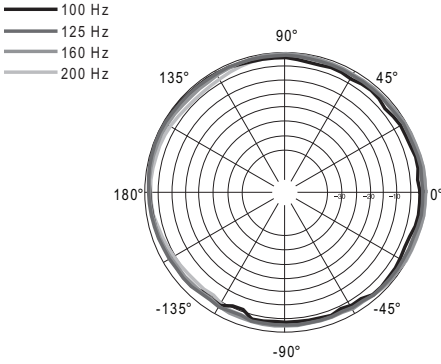

# SMS2124 Horizontal Polar Diagrams

- 100 Hz
- 125 Hz
- 160 Hz
- 200 Hz

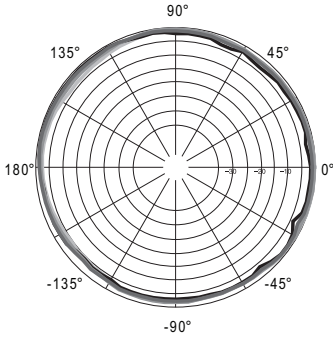

- 1600 Hz
- 2000 Hz
- 2500 Hz
- 3150 Hz

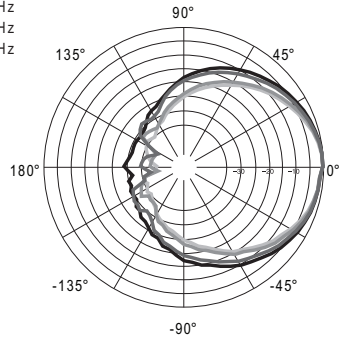

- 250 Hz
- 315 Hz
- 400 Hz
- 500 Hz

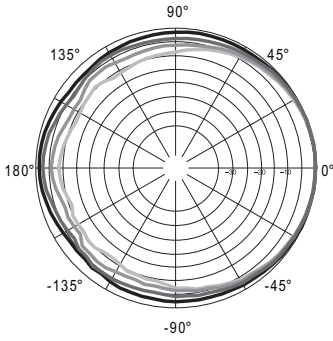

- 4000 Hz
- 5000 Hz
- 6300 Hz
- 8000 Hz

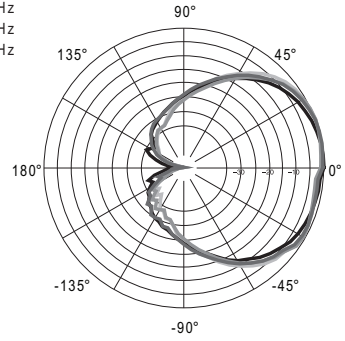

- 630 Hz
- 800 Hz
- 1000 Hz
- 1250 Hz

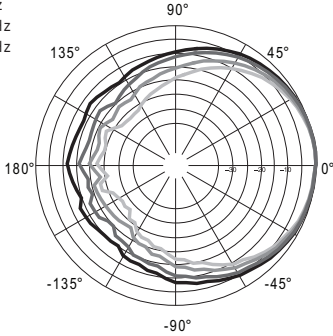

- 10000 Hz
- 12500 Hz
- 16000 Hz

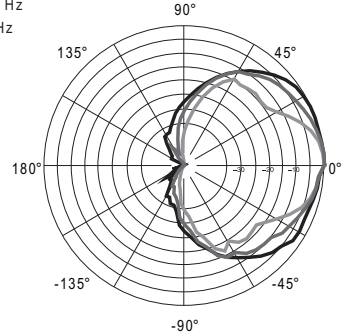

# SMS2990 Vertical Polar Diagrams

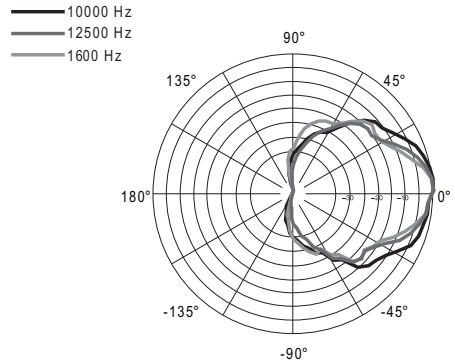
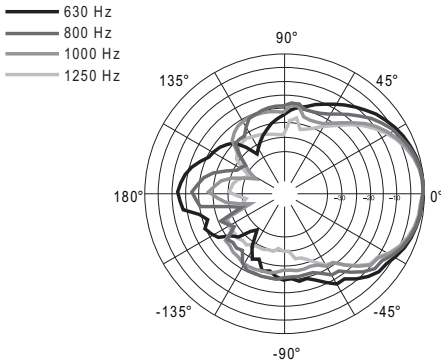
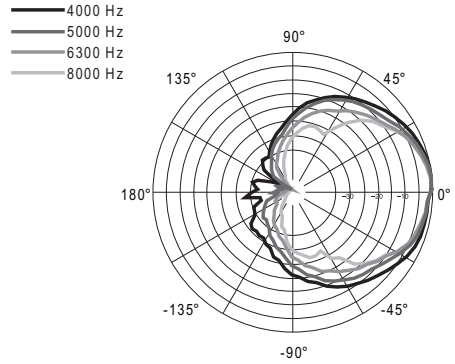
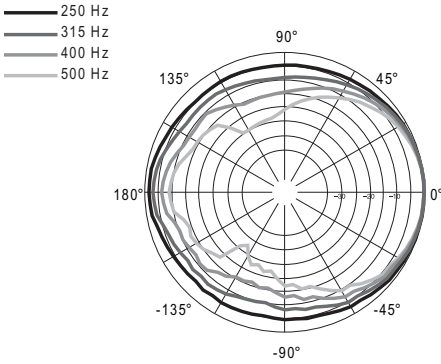
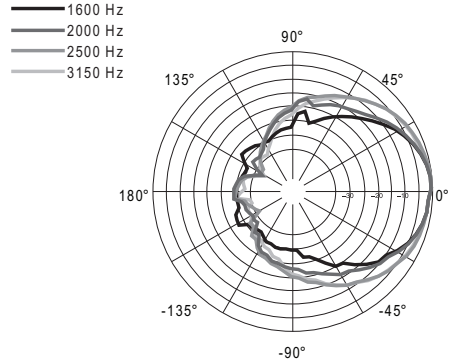
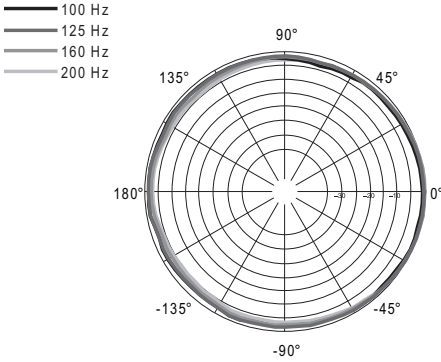

# SMS2990 Horizontal Polar Diagrams

- 100 Hz
- 125 Hz
- 160 Hz
- 200 Hz

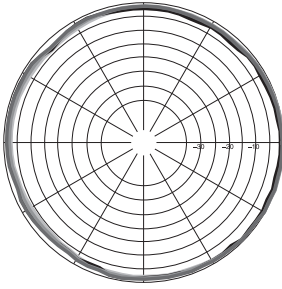

- 1600 Hz
- 2000 Hz
- 2500 Hz
- 3150 Hz

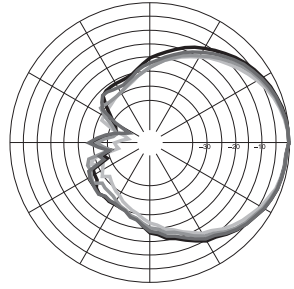

- 250 Hz
- 315 Hz
- 400 Hz
- 500 Hz

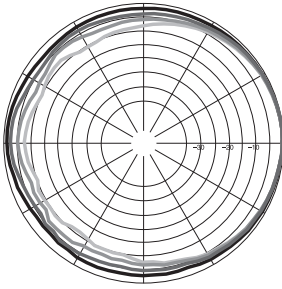

- 4000 Hz
- 5000 Hz
- 6300 Hz
- 8000 Hz

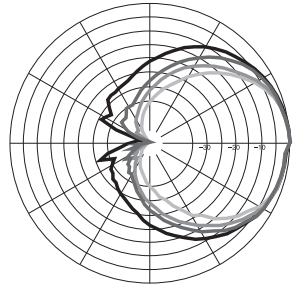

- 630 Hz
- 800 Hz
- 1000 Hz
- 1250 Hz

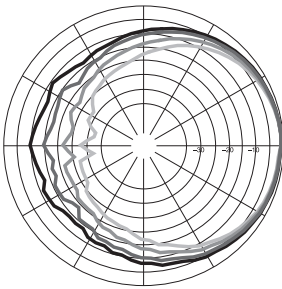

- 10000 Hz
- 12500 Hz
- 16000 Hz

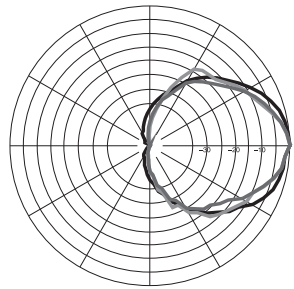

## 6. SERVICE INFORMATION

If your loudspeaker should require servicing, please follow these instructions:

1. Call EAW Commercial Tech Support at 1-888-337-7404, 7 am to 5 p.m. PST (Monday-Friday), to verify the problem and obtain a Return Authorization (RA) Number. Be sure to have the serial number of the unit when you call. You must have a Return Authorization Number in order to obtain warranty service at an authorized service center. You can also e-mail EAW Commercial Tech Support at: [service@eaw.com](mailto:service@eaw.com)
2. Pack the unit in its original packaging. THIS IS VERY IMPORTANT. LOUD Technologies is not responsible for any damage that occurs during shipping due to non-conventional packaging. Original packaging helps to minimize the possibility of shipping damage.
3. Include a legible note stating your name, return address (no P.O. boxes), daytime phone number, Return Authorization Number, and a detailed description of the problem, including how we can duplicate it.
4. Write the Return Authorization Number in BIG BOLD PRINT on the top of the box.
5. Tech Support will tell you where to ship the unit when you call for an RA Number. We suggest insurance for all forms of cartage.

## 7. EAW COMMERCIAL WARRANTY

**Warranty:** LOUD Technologies Inc. requires its authorized EAW Commercial distributors to abide by the following warranty terms for all EAW Commercial brand products (all dates are from the date of delivery from an Authorized EAW Commercial Distributor to the end user/installation site): Loudspeakers – 5 years; Active Electronics – 5 years; Accessories – 2 years.

**What Is Covered:** Defects in workmanship and materials and against malfunctions. EAW Commercial distributors must remedy all such defects and malfunctions without charge for parts or labor if the warranty applies. Final determination of warranty coverage lies solely with each authorized EAW Commercial distributor.

**What Is Not Covered:** This warranty does not extend to damage or malfunctions resulting from, but not limited to, shipment, improper installation, misuse, neglect, abuse, normal wear, accident, or to any product on which the serial number has been modified or removed. Exterior defects in or damage to the exterior appearance are specifically excluded from this warranty. EAW Commercial distributors shall not be liable for incidental or consequential damages resulting from the use of EAW Commercial products. Repairs and/or modifications by other than an Authorized EAW Commercial Distributor automatically voids this warranty.



**Correct Disposal of this product:** This symbol indicates that this product should not be disposed of with your household waste, according to the WEEE Directive (2002/96/EC) and your national law. This product should be handed over to an authorized collection site for recycling waste electrical and electronic equipment (EEE). Improper handling of this type of waste could have a possible negative impact on the environment and human health due to potentially hazardous substances that are generally associated with EEE. At the same time, your cooperation in the correct disposal of this product will contribute to the effective usage of natural resources. For more information about where you can drop off your waste equipment for recycling, please contact your local city office, waste authority, or your household waste disposal service.





**EAW Commercial** A LOUD Technologies Inc. Company

EAW Commercial | One Main Street | Whitinsville, MA 01588 USA | TEL toll free within US/Canada 888.337.7404  
TEL outside US 425.892.6503 | FAX 425.485.1152 | [www.eaw.com](http://www.eaw.com)

© 2008 LOUD Technologies Inc. All Rights Reserved.