

NOTES:

1. SYMBOL \odot INDICATES MOUNTING POINT, 3/8-16 THREADED HOLE (PI ANGLE).
2. SYMBOL \oplus INDICATES CENTER OF BALANCE.
3. WEIGHT APPROX. 154 LBS.
4. SHIPPING WEIGHT APPROX. 172 LBS.
5. ALLOW 4" CLEARANCE BEHIND CABINET FOR STRAIN RELIEF AND CABLE.

REV	DESCRIPTION	APVD/DATE
2	REVISED PER ECO #4724 DM 8/17/00.	KFH 9/6/00

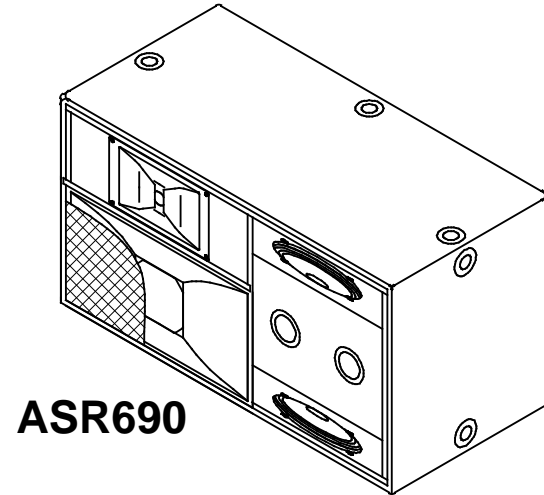

ASR690

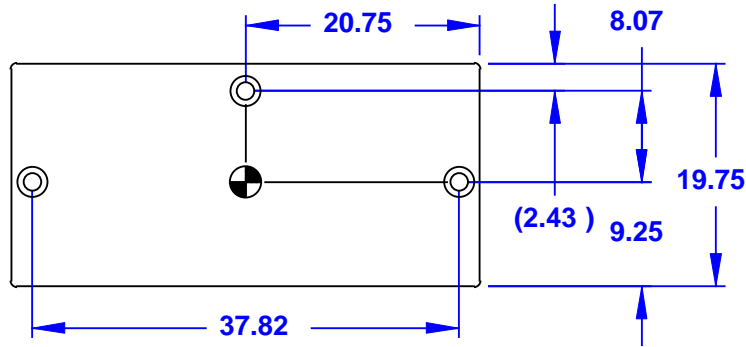

TOP
DIMENSIONS APPLY TO TOP & BOTTOM

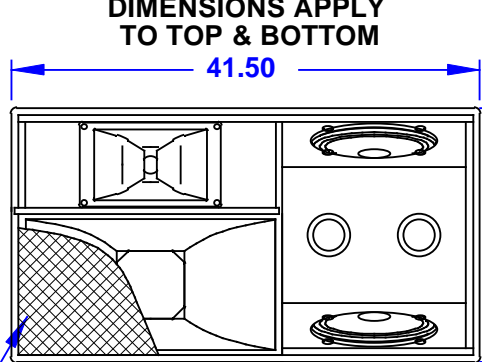

FRONT
GRILLE PARTIALLY SHOWN

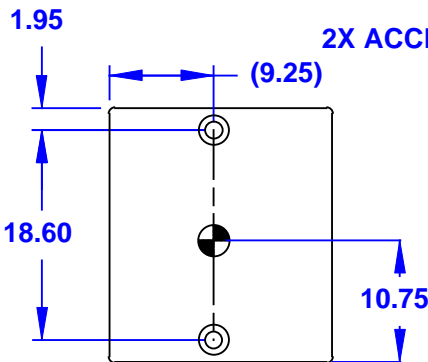

SIDE
DIMENSIONS APPLY TO BOTH SIDES

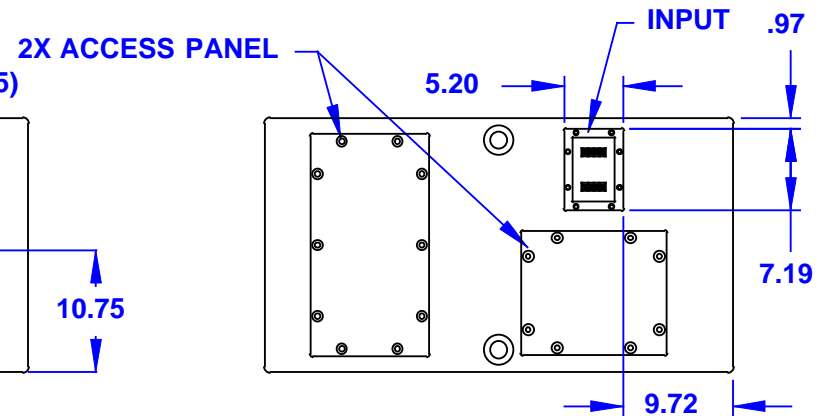

BACK

DOCUMENT CONTROL PER SPECIFICATION 4.5.201

<p>THIRD ANGLE PROJECTION</p>	<p>UNLESS OTHERWISE SPECIFIED: ALL DIMENSIONS ARE IN INCHES TOLERANCE IN INCHES .XX ± .13 ANGLES ±1°</p> <p>(X.XX) = REF DIMS NO TOLERANCE IMPLIED</p> <p>T.S.C.=THEORETICAL SHARP CORNER</p> <p>DIMENSIONS ACROSS CENTERLINES TO BE SYMMETRICAL</p>	<p>STATUS: PRODUCTION</p>		<p>EAOW EASTERN ACOUSTIC WORKS ONE MAIN STREET WHITINSVILLE, MA 01588 USA</p>
		<p>APPROVALS</p> <p>DRAWN: JAH</p> <p>CHECKED: FEL</p> <p>DES ENG: ZC</p> <p>MFG ENG: KRV</p>	<p>DATE</p> <p>2/27/98</p> <p>2/27/98</p> <p>2/27/98</p> <p>2/27/98</p>	
<p>THIS DRAWING IS THE PROPERTY OF EAOW AND SHALL NOT BE COPIED, REPRODUCED, OR USED AS THE BASIS FOR MANUFACTURE OR SALE OF APPARATUS WITHOUT WRITTEN AUTHORIZATION. DO NOT SCALE DRAWING.</p>		<p>SCALE: 1 TO 16</p>		<p>DRAWING NUMBER: 510631</p>
				<p>REVISION: 2</p>