

# Installation Instructions

## CB523/CB523M BRACKET

EAW DWG NO 480361 (0)

### 1. Inventory

Before beginning installation, inventory kit to items listed.

Item	EAW P/N	Qty	Description
1	606098	1	Bracket
2	102246	3	Screw, 3/8-16 x 1-1/2, SHCS, Black
3	105062	2	Washer, Neoprene, 3/8 I.D. X 1 O.D.
4	105010	3	3/8 Washer, Flat, Black
5	105011	3	3/8 Washer, Lock, Black

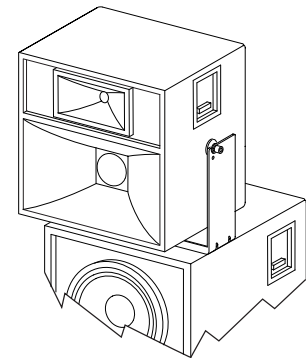

### 2. Removing the Shipping Hardware

Using a 7/32 Allen wrench, remove the middle screw from the top of the BV253C cabinet and the flat head screw from the each side of the HK523 (HK523M) cabinet.

### 3. Mounting the Bracket

Position the bracket on the BV253C cabinet. The bracket's center elongated hole must face forward. Insert a hex head screw with its lock washer and flat washer thru the slot into the cabinet's threaded hole and hand tighten, to allow side-to-side horizontal aiming.

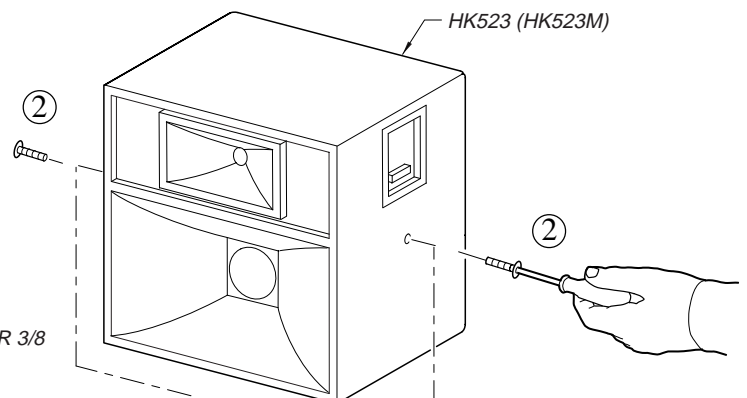

### 4. Hanging the HK523 Cabinet

A. Insert a hex head screw, lock washer, flat washer and neoprene washer into the left side of the cabinet.

B. Repeat step A through the opposite side of the cabinet.

C. With the cabinet's side screws loose, lower the cabinet onto the open slot on the bracket. The neoprene gasket must be between the bracket and cabinet as shown.

D. Aim the HK523 (HK523M) cabinet and tighten the three screws with a 5/16 Allen wrench.

(3) FLAT WASHER 3/8  
EAW P/N 105010

(4) (3) SCREW 3/8-16 X 1-1/2  
SHCS 18-8 BLK  
EAW P/N 102246

(2) NEOPRENE WASHER  
EAW P/N 105062

(3) LOCK WASHER 3/8  
EAW P/N 105011

CENTER  
ELONGATED HOLE

MOUNTING BRACKET  
HK523 EAW P/N 606098

