

NOTES.

1. MATERIAL: 13 GA (.09) LOW CARBON CRS
2. FINISH: BLACK MATTE POWDERCOAT.
3. REMOVE BURRS AND SHARP EDGES.
4. PARTS TO BE CLEANED AND FREE OF GREASE AND DEBRIS
5. EAW PART NUMBER AND CURRENT REVISION TO BE STAMPED OR PRINTED IN AREA SHOWN WITH INDELIBLE WHITE INK.
6. REFER TO EAW MATERIAL SPECIFICATION 480455 FOR LABELING AND SHIPPING REQUIREMENTS.

REV	DESCRIPTION	APVD/DATE
0	NEW ISSUE WAS 606087 (3) PER DSR 00-431 4/7/00	DM 4/26/00

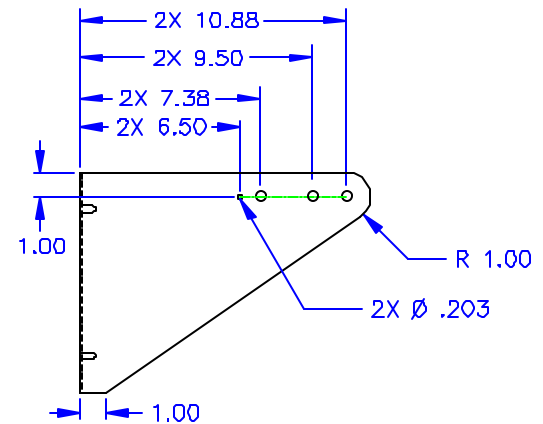
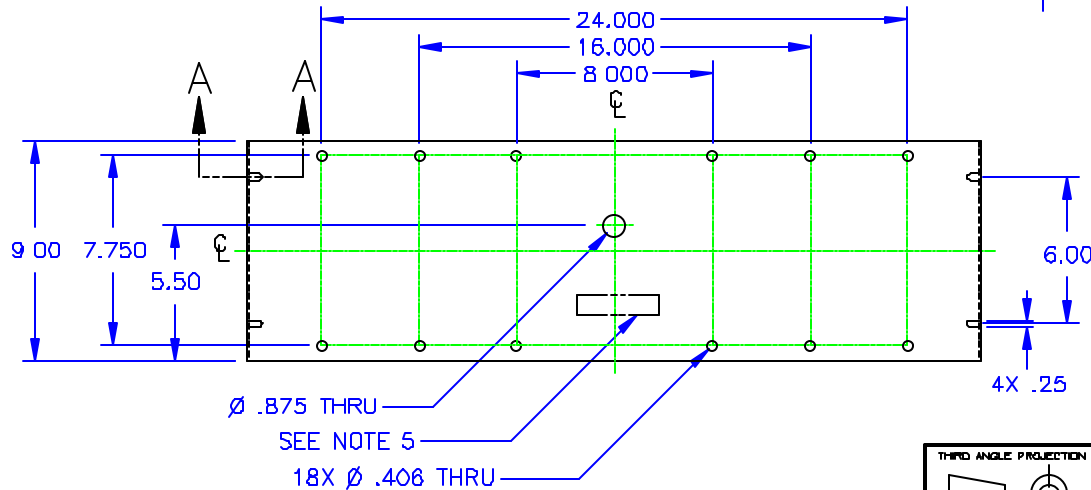
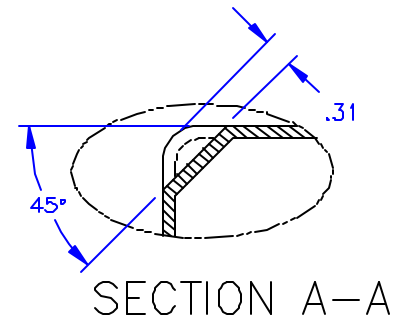
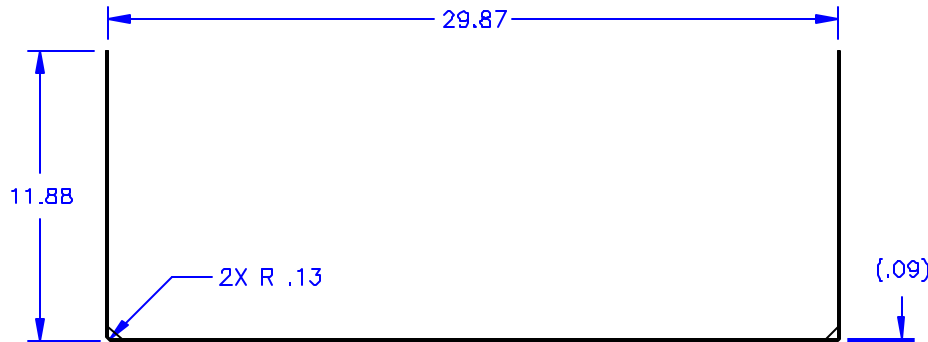

DOCUMENT CONTROL PER SPECIFICATION 4.5.201

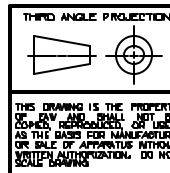

UNLESS OTHERWISE SPECIFIED:
ALL DIMENSIONS ARE IN INCHES
TOLERANCE IN INCHES
X ± .1 XX ± .03 XXX ± 0.10
FRACTIONS ± 1/32
ANGLES ± 1/2°
XXX = REF DIMS
NO TOLERANCE IMPLIED
T B C = THEORETICAL SHARP CORNER
DIMENSIONS ACROSS CENTERLINES
TO BE SYMMETRICAL

STATUS	PRODUCTION	
	APPROVALS	DATE
DRAWN	MFL	4/7/00
CHECKED	DM	4/26/00
DESIGN	JAR	4/27/00
MFG ENG	MCB	4/28/00

EAW EASTERN ACOUSTIC WORKS ONE MARK STREET MARTINSVILLE, VA 24108 USA	
TITLE BRACKET/WALLMOUNT/CR57e	
B SHEET 1 OF 1	SCALE 1 TO 3
DRAWING NUMBER 606154	REVISION 0

THIS DRAWING IS THE PROPERTY OF EAW AND SHALL NOT BE COPIED, REPRODUCED, OR USED AS THE BASIS FOR MANUFACTURE OR SALE OF ANY PARTS WITHOUT WRITTEN AUTHORIZATION. DO NOT SCALE DRAWING.