

| REV | DESCRIPTION   | APVD/DATE     |
|-----|---|---------------|
| 0   | NEW ISSUE WAS 6061219 (0)<br>PER DSR 00-431 MFL 4/12/00 | DM<br>4/26/00 |

NOTES:

1. MATERIAL: 10 GA (.134) CRS
2. FINISH: BLACK MATTE POWDERCOAT.
3. REMOVE BURRS AND SHARP EDGES.
4. PARTS TO BE CLEANED AND FREE OF GREASE AND DEBRIS.
5. EAW PART NUMBER AND CURRENT REVISION TO BE STAMPED OR PRINTED IN AREA SHOWN WITH INDELIBLE WHITE INK.
6. REFER TO EAW MATERIAL SPECIFICATION 480455 FOR LABELING AND SHIPPING REQUIREMENTS.

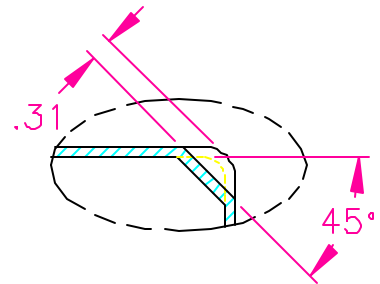

SECTION A-A

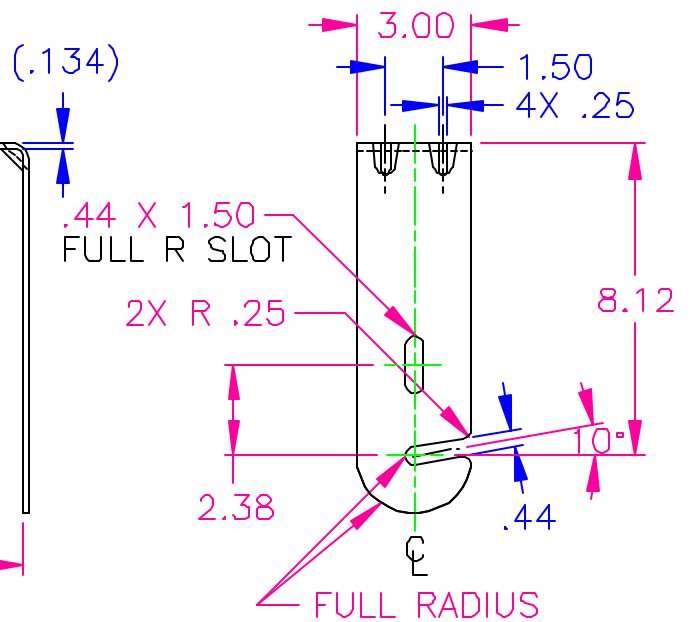
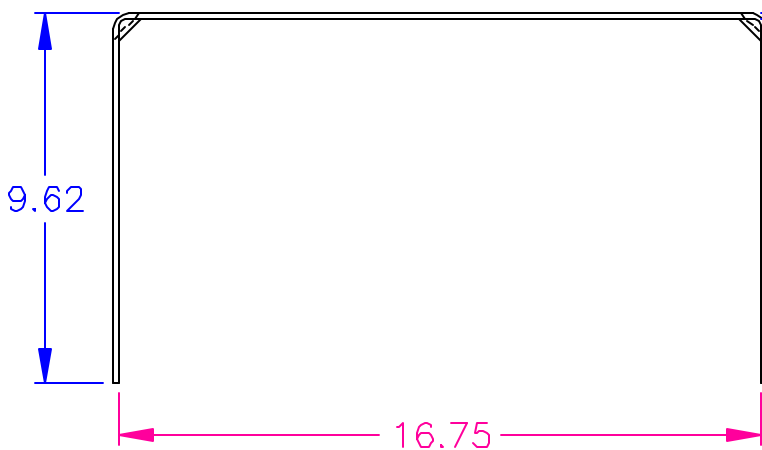
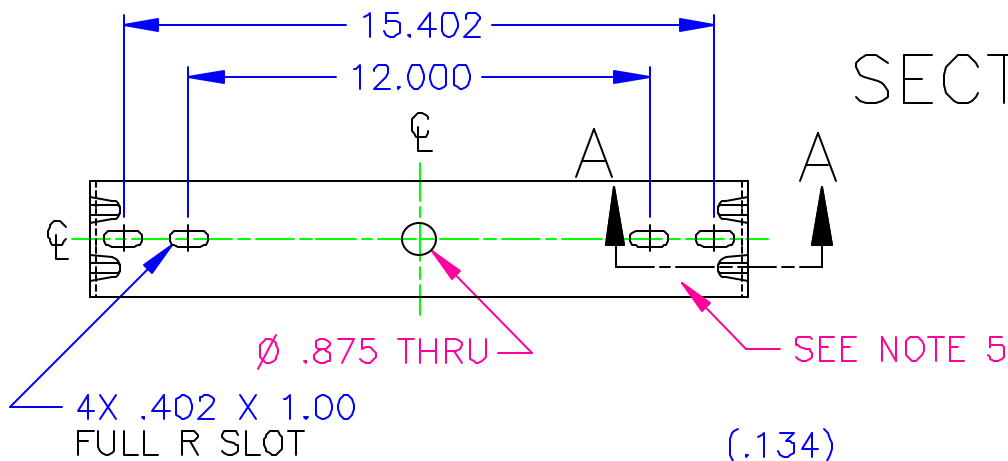

DOCUMENT CONTROL PER SPECIFICATION 4 5.201

|   |   |  |             |   |
|---|---|--|-------------|---|
| <p>THIRD ANGLE PROJECTION</p>   | <p>UNLESS OTHERWISE SPECIFIED:<br/>ALL DIMENSIONS ARE IN INCHES</p> <p>TOLERANCE IN INCHES<br/>.X ± .1 .XX ± .03 .XXX ± .010<br/>FRACTIONS ± 1/32<br/>ANGLES ± 1/2°</p> <p>(X.XX) = REF DIMS<br/>NO TOLERANCE IMPLIED</p> <p>T.S.C.=THEORETICAL SHARP CORNER</p> <p>DIMENSIONS ACROSS CENTERLINES<br/>TO BE SYMMETRICAL</p> | <p>STATUS: <b>PRODUCTION</b></p>   |             | <p><b>EAW</b> EASTERN ACOUSTIC WORKS<br/>ONE MAIN STREET<br/>WHITINSVILLE, MA 01588 USA</p> |
|   |   | <p>APPROVALS</p> <p>DRAWN: MFL 4/12/00</p> <p>CHECKED: DM 4/26/00</p> <p>DES ENG: JR 4/27/00</p> <p>MFG ENG: MCB 4/28/00</p> | <p>DATE</p> |   |
| <p>THIS DRAWING IS THE PROPERTY<br/>OF EAW AND SHALL NOT BE<br/>COPIED, REPRODUCED, OR USED<br/>AS THE BASIS FOR MANUFACTURE<br/>OR SALE OF APPARATUS WITHOUT<br/>WRITTEN AUTHORIZATION. DO NOT<br/>SCALE DRAWING</p> |   |  |             | <p><b>A</b> SHEET 1 OF 1 SCALE 1 TO 5</p>   |
|   |   |  |             | <p>DRAWING NUMBER: 606157 REVISION: 0</p>   |