



Instructions/Installation Cover Plate Assembly, DSA

The Cover Plate Assembly, DSA should be installed on the bottom of the lowest enclosure of a cluster. Looking up at the uncovered bottom of a cluster you will see the contrast between the dark electrical panel and the light finish of the enclosure. The Cover Plate Assembly, DSA is designed to hide the dark electrical panel and finish the installation.

Warning: Installing the Cover Plate Assembly, DSA should only be done by an experienced technician. Improper installation may result in damage to the equipment or injury.

KIT/COVER PLATE/WHITE/DSA PARTS LIST, EAW P/N0011405:

Item	EAW P/N	Qty	Description
A	0011270	1	Plate Cover, DSA
B	0011399	4	Screw, 8-32 x 3/4 Lg PH PHMS Zinc
C	0011404	4	Rivet Nut/Neoprene/Brass/8-32 x 1/2 Lg
D	RD0179	1	Instructions, Installation, Cover Plate Kit/DSA (this sheet)

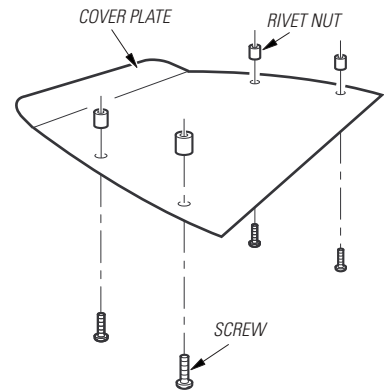

1. ASSEMBLING END COVER

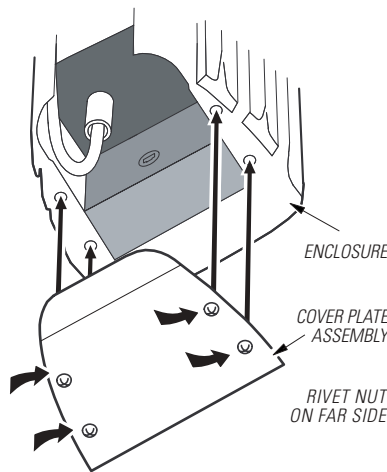

2. END PLATE INSTALLATION

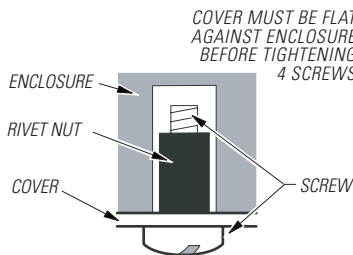

3. BEFORE TIGHTENING

COMPRESS RIVET NUTS BY TIGHTENING EACH SCREW UNTIL COVER IS HELD TIGHTLY.

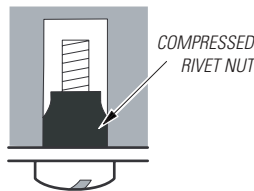

4. AFTER TIGHTENING

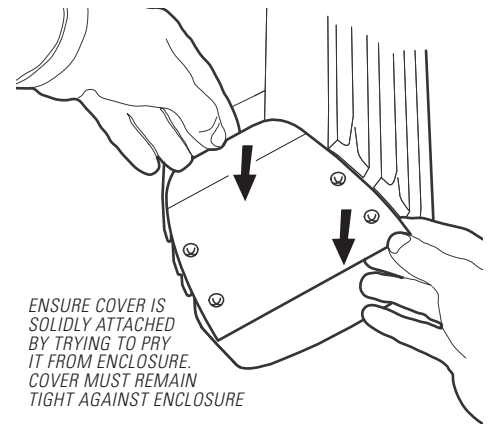

5. TESTING INSTALLATION

Thank you for purchasing EAW products

If you have questions about DSA End Cover Assembly please contact the EAW Application Support Group by one of the methods below, or by e-mail at asg@eaw.com.

