



SPECIFICATIONS JF590z

FEATURES

- High output two-way loudspeaker systems with 15-in woofer and 1.4-in exit/3-in voice coil HF compression driver on 90° x 45° constant directivity horn
- Beamwidth matching crossover point selection for smooth power response
- Switchable powering: internal passive crossover or bi-amplified operation
- Handles and pole mount cup for portable applications
- 3/8"-16 threaded mounting points for permanent installation

DESCRIPTION

EAW's JF590z two-way loudspeaker system provides high output, low distortion sound reinforcement for the entire range of pro audio applications.

The newly re-engineered 15-in low frequency cone and 1.4-in exit 3-in voice coil high frequency compression driver provides higher output and lower distortion plus enhanced power handling capabilities for better performance in both portable and permanently installed applications. The new constant directivity HF horn – inspired by the new AS Series systems – provides optimized dispersion of HF information without problematic beaming.

EAW's advanced beamwidth matching crossover selects a crossover point where the HF horn's beamwidth matches that of the woofer. The result is more even off-axis frequency response (power response) for more complete coverage.

The JF590z offers a switchable powering mode: passive operation using the internal crossover filter network or bi-amplified operation requiring the use of pre-configured MX Series processor settings.

APPLICATION

The JF590z was designed to support the widest possible range of pro audio applications and was optimized for use in distributed systems.

The pole mount cup and balance-optimized handles allow for quick and easy load-in of portable uses. Its high output capabilities let it act as a main system for smaller concert or portable A/V events or even provide front or side fill for concert touring applications.

The comprehensive system of integral 3/8"-16 threaded mounting points permit safe, load-rated suspension in permanent installations.



PERFORMANCE

Frequency Response (1 Watt @ 1m, MX200i Processing)

±3 dB	56 Hz to 18 KHz
-10 dB	50 Hz

Axial Sensitivity (dB SPL, 1 Watt @ 1m)

Full Range	97
LF	97
HF	105

Impedance (Ohms)

Full Range	8
LF	8
HF	16

Power Handling, AES Standard (Watts)

Full Range	500
LF	800
HF	200

Calculated Maximum Output (dB SPL)

Full Range Peak	130.0
LF Peak	132.0
HF Peak	134.0
Full Range Long Term	124.0
LF Long Term	126.0
HF Long Term	128.0

PHYSICAL

Configuration	2-way, full range
Powering	Switchable: passive (LF/HF crossover) or bi-amplified
LF Subsystem	1x 15-in, vented
HF Subsystem	1x 1.4-in exit/3-in voice coil compression driver on CD horn





SPECIFICATIONS JF590z

DIMENSIONAL DRAWING

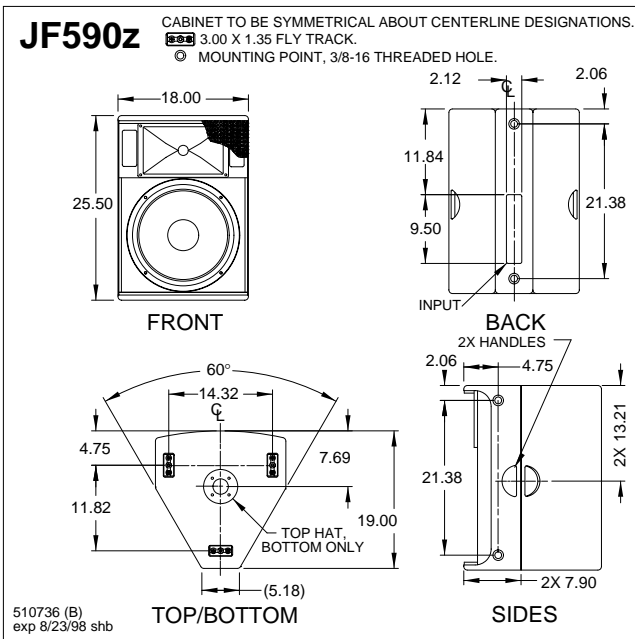

PHYSICAL

Coverage Angles (h° x v°)	90 x 45
Cabinet Type (shape)	Trapezoidal
Enclosure Materials	Baltic birch plywood
Finish	Black polyurethane
Connectors	2x Neutrik NL4 Speakon
Suspension Hardware	(6) 3/8"-16 threaded mounting/suspension points (2 each back and sides), (6) 3 position flytrack (3 each top and bottom), stand mount cup (bottom)
Grille	Powder coated perforated steel, foam backed
Controls (switches, knobs)	Powering mode switch

Dimensions	inches	millimeters
Height	25.50	648
Width (Front)	18.00	457
Width (Rear)	5.18	132
Depth (Max)	19.00	483
Trapezoid Angle	30 degrees per side	

Weights	pounds	kilograms
Net Weight	83	37.8
Shipping Weight	90	41.0

SERVICE ITEMS

LF: Complete Cone Driver:	EAW Part No.	804083
HF: Complete Compression Driver/Tweeter:	EAW Part No.	803045
HF: Diaphragm Assembly:	EAW Part No.	806049

LF: Recone Assembly:

EAW Part No. 460060

Filter/Crossover Network: Complete Assembly

EAW Part No. 225420

A & E SPECIFICATIONS

The two-way full range loudspeaker systems shall incorporate a 15-in LF transducers and a 1.4-in exit/3-in voice coil compression driver HF transducer.

The LF driver shall be mounted in a vented enclosure tuned for optimum low frequency response. The HF driver shall be loaded on a constant directivity horn with a nominal coverage pattern of 90° (h) x 45° (v).

A switch shall be provided allowing the user to select between bi-amplified or full range passive powering modes. In full range passive mode, an internal passive filter network shall provide fourth order acoustical crossover and system equalization between the low and high frequency sections.

System frequency response shall vary no more than ± 3 dB from 56 Hz to 18 kHz measured on axis. In full range mode, the system shall produce a Sound Pressure Level (SPL) of 97 dB SPL on axis at 1 meter with a power input of 1 Watt, and shall be capable of producing a peak output of 130.0 dB SPL on axis at 1 meter. In full range mode, the system shall handle 500 Watts of amplifier power (AES Standard) and shall have a nominal impedance of 8 Ohms.

In bi-amplified mode, the low frequency section shall produce a Sound Pressure Level (SPL) of 97 dB SPL on axis at 1 meter with a power input of 1 Watt, and shall be capable of producing a peak output of 132.0 dB SPL on axis at 1 meter, and the high frequency section shall produce a Sound Pressure Level (SPL) of 105 dB SPL on axis at 1 meter with a power input of 1 Watt, and shall be capable of producing a peak output of 134.0 dB SPL on axis at 1 meter. In bi-amplified mode, the low frequency section shall handle 800 Watts of amplifier power (AES Standard) and shall have a nominal impedance of 8 Ohms and the high frequency section shall handle 200 Watts of amplifier power and shall have a nominal impedance of 16 Ohms.

The loudspeaker enclosure shall be trapezoidal in shape. It shall be constructed of 1/2-in thickness void-free cross-grain-laminated Baltic birch plywood and shall employ extensive internal bracing. It shall be finished in black catalyzed polyurethane. Input connectors shall be dual Neutrik NL4. A total of 6x 3/8"-16 threaded mounting/suspension points (2 each sides and back) shall be provided as well as 6x 3-position flytracks (3 each top and bottom). A stand mount cup shall be provided on the bottom of the enclosure. The front of the loudspeaker shall be covered with a powder coated perforated steel grille.

The 2-way full range loudspeaker shall be the EAW model JF590z.