



REV	CHANGE NUMBER	DATE
A	ECOWHT6969	10/8/10

- NOTES:
1. SYMBOL  INDICATES CENTER OF BALANCE.
 2. SYMBOL  INDICATES MOUNTING POINT, M10 THREADED HOLE.
 3. SYMBOL  INDICATES MOUNTING POINT, M10 THREADED HOLE FOR OMNIMOUNT 120.0 SERIES.
 4. WEIGHT APPROX. 33 kg [72.4 lb]
 5. SHIPPING WEIGHT APPROX. 38 kg [83.4 lb]



JF56NT
JF59NT

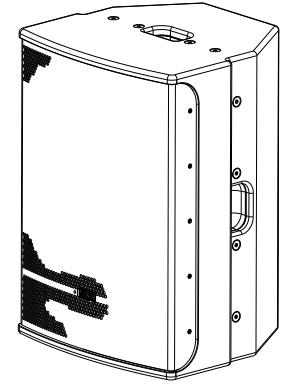
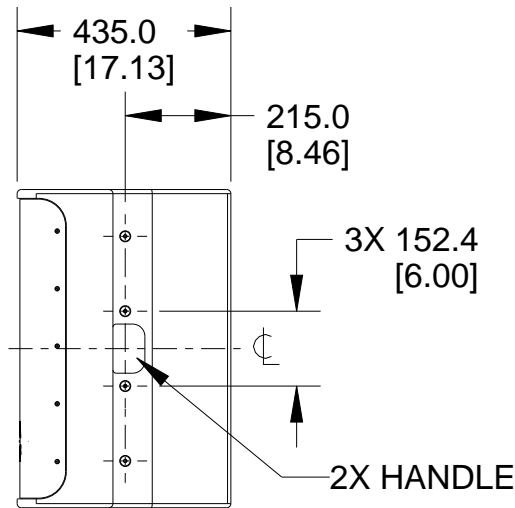
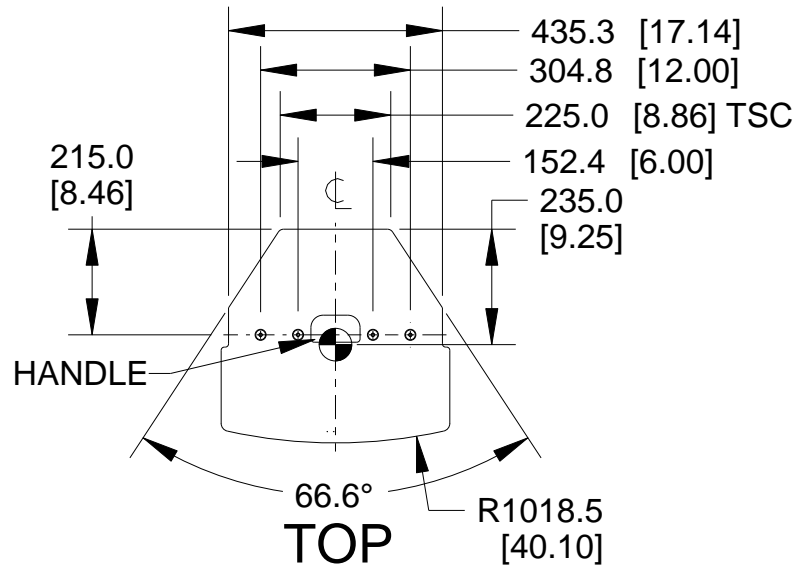

POWER AMPLIFIER

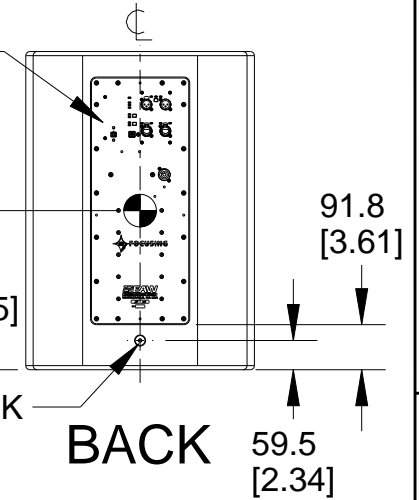

RIGHT SIDE
DIMENSIONS APPLY
TO BOTH SIDES

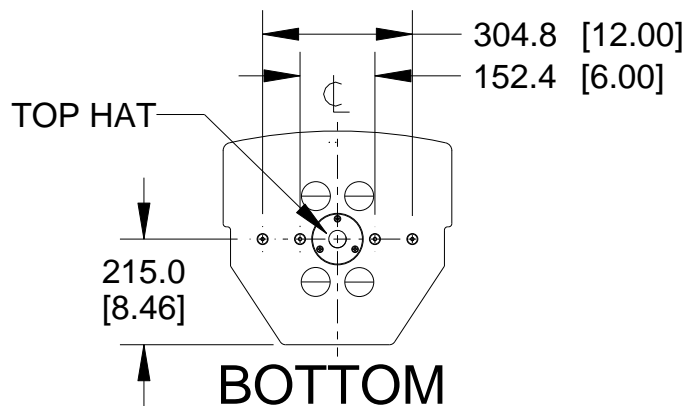
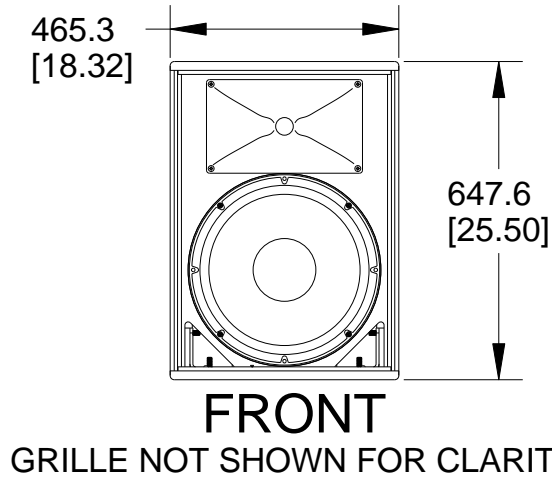

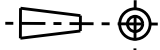
<p>THIRD ANGLE PROJECTION</p> 	<p>UNLESS OTHERWISE SPECIFIED: ALL DIMENSIONS ARE IN MILLIMETERS DUAL [INCHES] DIMENSIONS FOR REF ONLY</p> <p>TOLERANCE IN MILLIMETERS LINEAR ± 3.3 mm / ± 0.13 in ANGLES ± 1°</p> <p>(X.XX) = REF DIMS NO TOLERANCE IMPLIED</p> <p>TSC = THEORETICAL SHARP CORNER</p> <p>DIMENSIONS ACROSS CENTERLINES TO BE SYMMETRICAL</p>	<p>EAW www.eaw.com</p>	
		<p>TITLE: DWG CUSTOMER JF56NT JF59NT [MECHANICAL SPECIFICATION]</p>	
<p>THE INFORMATION CONTAINED HEREIN IS PROPRIETARY AND CONFIDENTIAL PROPERTY OF LOUD TECHNOLOGIES, INC. ALL RIGHTS RESERVED</p>	<p>DRAWING NUMBER: 2034636-CD</p>	<p>A</p>	<p>SHEET 1 OF 1</p>
		<p>SCALE: 0.065</p>	<p>REVISION: A</p>