

- NOTES:
1. MATERIAL: 10 GA (.134) CRS
 2. FINISH: BLACK MATTE POWDERCOAT.
 3. REMOVE BURRS AND SHARP EDGES.
 4. PARTS TO BE CLEANED AND FREE OF GREASE AND DEBRIS.
 5. EAW PART NUMBER AND CURRENT REVISION TO BE STAMPED OR PRINTED IN AREA SHOWN WITH INDELIBLE WHITE INK.
 6. REFER TO EAW MATERIAL SPECIFICATION 480455 FOR LABELING AND SHIPPING REQUIREMENTS.
 7. ALL DIMENSIONS IN BRACKETS ARE IN [MILLIMETERS].

REV	DESCRIPTION	APVD/DATE
A	ORACLE REVISION CONVERSION DRAWING WAS REVISION 0 UPDATED PER ECO #5151 JH 3/22/01	SS 6/04/01
B	UPDATE REVISION OF BRACKET TO REFLECT AGILE PART REV. MELANIE 11/4/02	RS 11/12/02
C	MADE ALL DIMENSIONS DUAL, SEE NOTE 7. 3X REPLACED Ø .313 THRU HOLES WITH .39 X 2.39 FULL R SLOTS, SEE TOP VIEW. REMOVED DIM (.134). DIM 21.21 INSIDE WAS 21.13, 10.3 WAS 10.25, SEE FRONT VIEW. DIM .3 WAS .31. 4X 45° WAS 45°, SEE SECTION A-A. DIM 2X 2.00 WAS 2X 2.000. 4X ADDED NOTCHES TO SIDE SLOTS, SEE ADDED DETAIL B AND SIDE VIEW PER ECOWHT3533 MELANIE 9/13/04	KFH 9/15/04

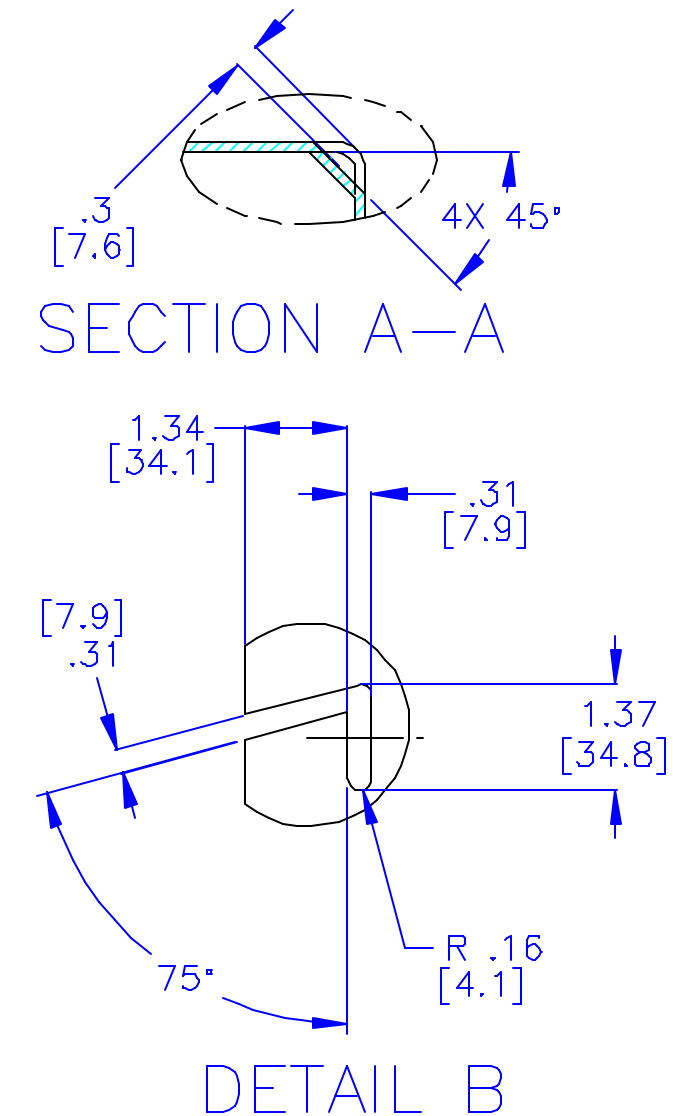
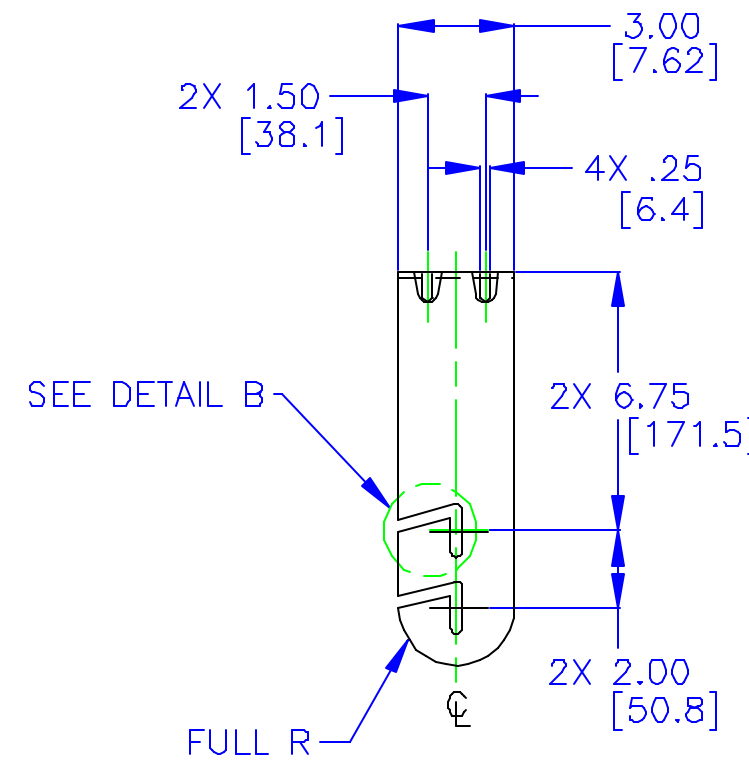
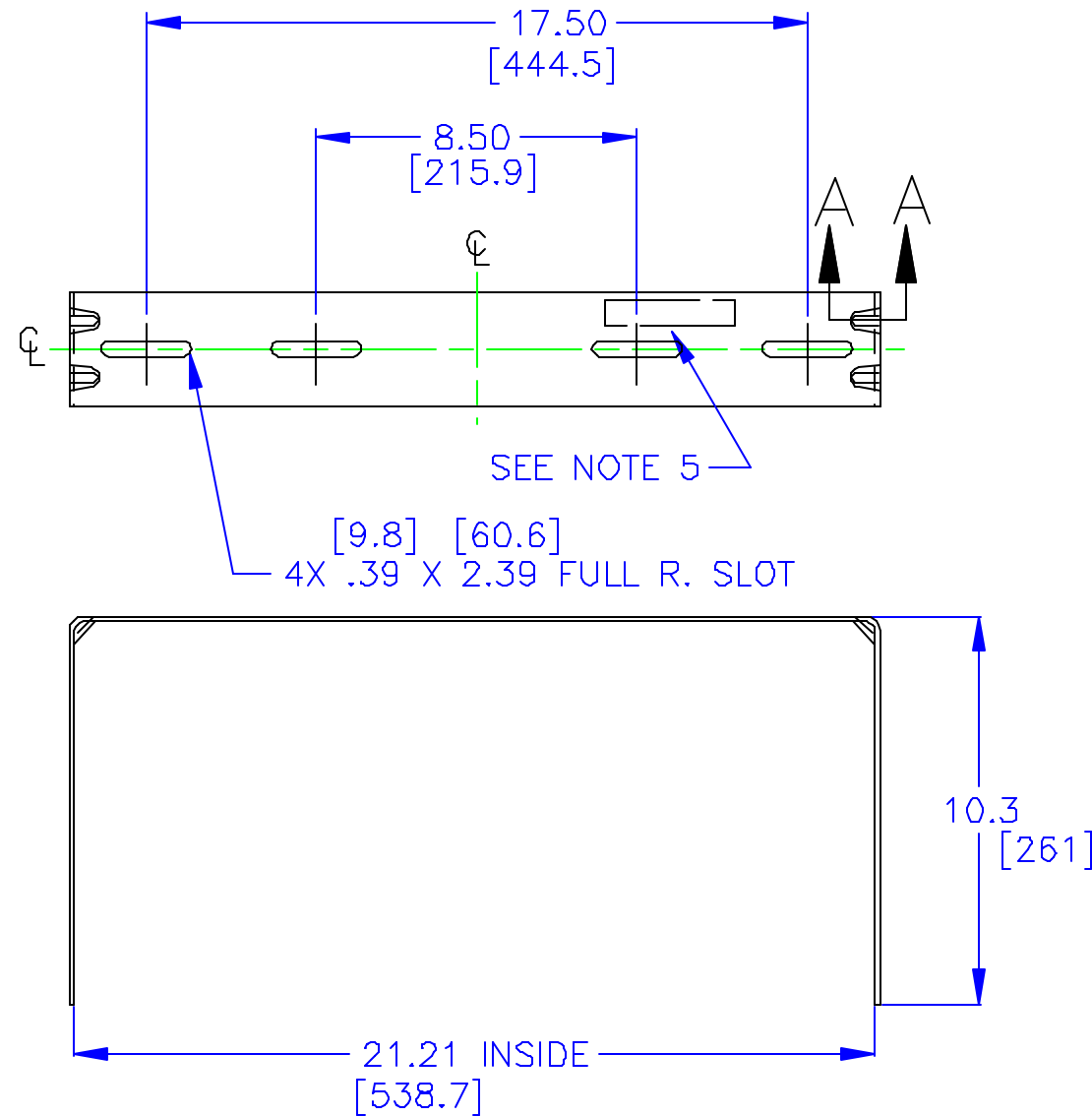
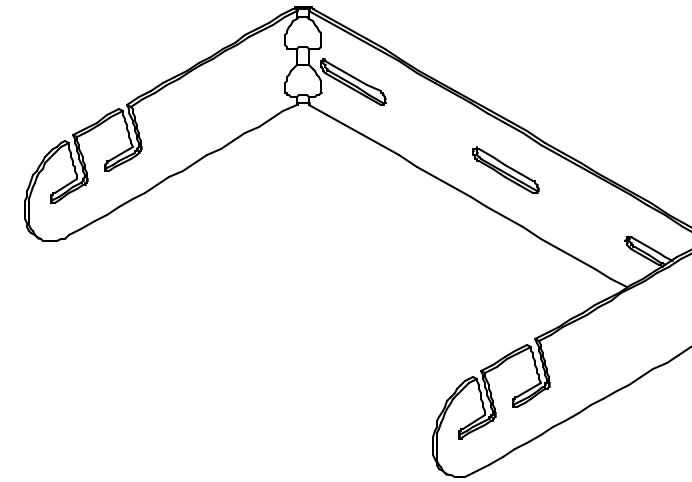

DOCUMENT CONTROL PER SPECIFICATION 4.5.201

THIRD ANGLE PROJECTION 	UNLESS OTHERWISE SPECIFIED: ALL DIMENSIONS ARE IN INCHES TOLERANCE IN INCHES .X ± .1 .XX ± .03 .XXX ± .010 FRACTIONS ± 1/32 ANGLES ± 1/2° (X.XX) = REF DIMS. NO TOLERANCE IMPLIED T.S.C.=THEORETICAL SHARP CORNER DIMENSIONS ACROSS CENTERLINES TO BE SYMMETRICAL	STATUS: PRODUCTION		EASTERN ACOUSTIC WORKS ONE MAIN STREET WHITINSVILLE, MA 01588 USA
		APPROVALS	DATE	
THIS DRAWING IS THE PROPERTY OF EAW AND SHALL NOT BE COPIED, REPRODUCED, OR USED AS THE BASIS FOR MANUFACTURE OR SALE OF APPARATUS WITHOUT WRITTEN AUTHORIZATION. DO NOT SCALE DRAWING.		DRAWN: MFL	4/3/00	SHEET 1 OF 1
		CHECKED: DM	4/26/00	SCALE: 1 TO 5
		DES ENG: JAR	4/27/00	DRAWING NUMBER: 606150
		MFG ENG: MCB	4/28/00	REVISION: C