



REV	DESCRIPTION	APVD/DATE
4	REVISED PER ECO #4724 DM 7/12/00	KFH 9/6/00

**NOTES:**

1. SYMBOL  INDICATES 19.00 X 1.35 FLYTRACK.
2. SYMBOL  INDICATES CENTER OF BALANCE.
3. WEIGHT APPROX. 250 LBS.
4. SHIPPING WEIGHT APPROX. 258 LBS.

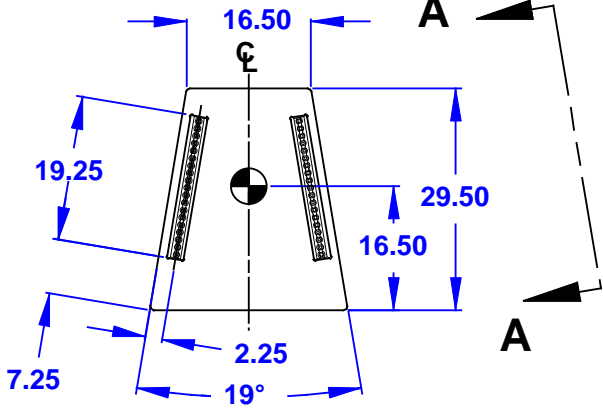

**TOP**

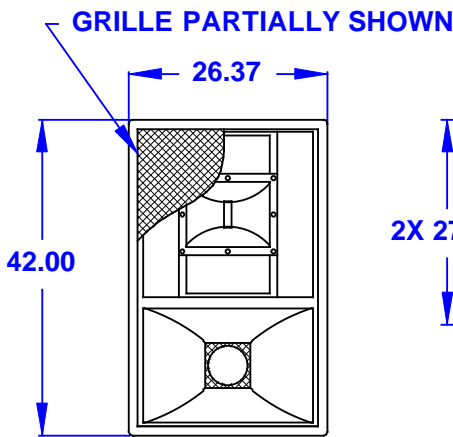

**FRONT**

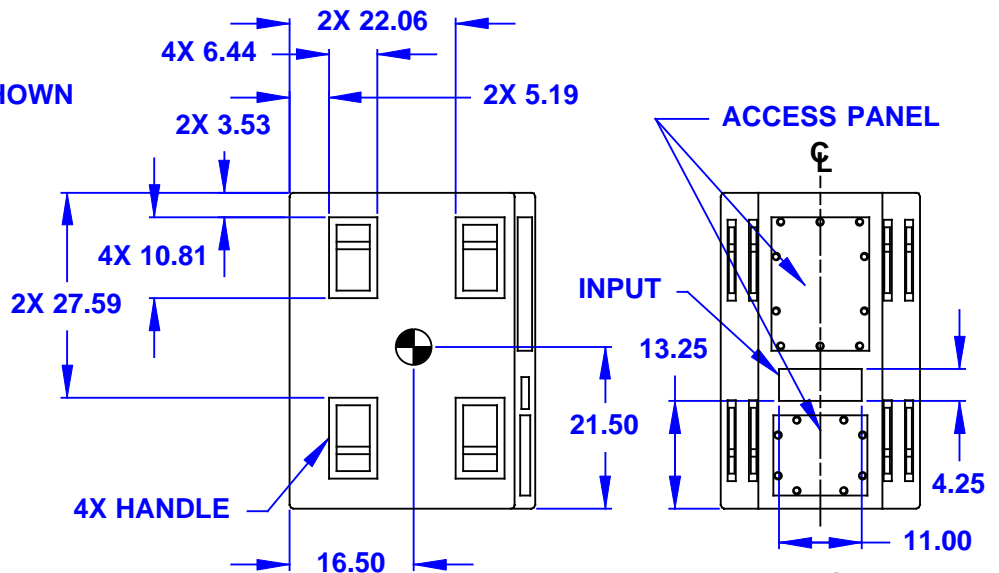

**VIEW A-A**

**BACK**

DIMENSIONS APPLY TO BOTH SIDES

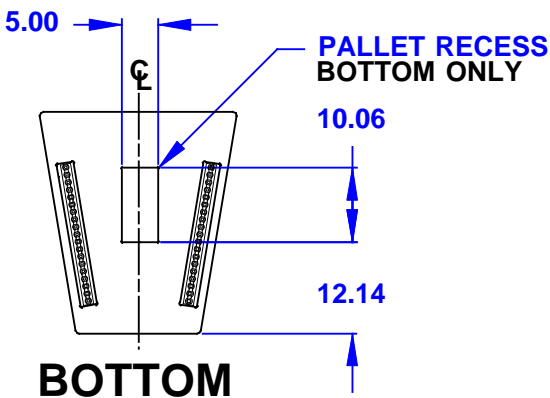

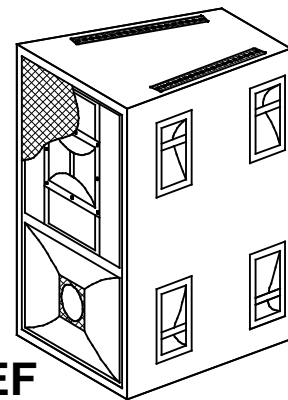

**BOTTOM**

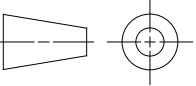

**KF850EF**

DOCUMENT CONTROL PER SPECIFICATION 4.5.201

<p>THIRD ANGLE PROJECTION</p>  <p>THIS DRAWING IS THE PROPERTY OF EAW AND SHALL NOT BE COPIED, REPRODUCED, OR USED AS THE BASIS FOR MANUFACTURE OR SALE OF APPARATUS WITHOUT WRITTEN AUTHORIZATION. DO NOT SCALE DRAWING.</p>	<p>UNLESS OTHERWISE SPECIFIED: ALL DIMENSIONS ARE IN INCHES</p> <p>TOLERANCE IN INCHES .XX ± .13 ANGLES ±1°</p> <p>(X.XX) = REF DIMS NO TOLERANCE IMPLIED</p> <p>T.S.C.=THEORETICAL SHARP CORNER</p> <p>DIMENSIONS ACROSS CENTERLINES TO BE SYMMETRICAL</p>	STATUS: <b>PRODUCTION</b>		 <b>EASTERN ACOUSTIC WORKS</b> ONE MAIN STREET WHITINSVILLE, MA 01588 USA	
		APPROVALS	DATE		<p>TITLE: CABINET/FINISHED/KF850EF [MECHANICAL SPECIFICATION]</p>
		DRAWN: RAS	2/5/96		
		CHECKED: N/A	N/A		
		DES ENG: N/A	N/A		
MFG ENG: N/A	N/A				
<p>A</p>		<p>SHEET 1 OF 1</p>		<p>SCALE: 1 TO 24</p>	
<p>DRAWING NUMBER: 510164</p>			<p>REVISION: 4</p>		