



TECHNICAL SPECIFICATIONS KF850EF

DESCRIPTION

A 3-way triamplified full range system in a trapezoidal enclosure. Includes a 15-in woofer in a wave guide cavity with ARC™ device, a horn-loaded 10-in midrange cone and a 2-in exit compression driver mounted coaxially in the wave guide cavity on a 55 x 40 constant directivity horn..

APPLICATIONS

The KF850 Virtual Array loudspeaker is the world touring standard, accepted in more technical riders than any other loudspeaker. True 3-way design dramatically improves the quality of vocal reproduction while the cone-driven midrange horn and horn-loaded woofer extend pattern control to the lowest octaves. Effective for large format permanent or portable applications. Six year warranty.

Applications include:

- | | |
|----------------|------------------|
| Concert Tours | Corporate Events |
| Large Theaters | Stadiums |
| Cathedrals | Live Music Clubs |

DESCRIPTIVE DATA

Part Number	999100
Product Group	S
LF Subsystem & Loading	1x 15-in Horn Loaded Cone in Wave Guide Cavity with ARC™
MF Subsystem & Loading	1x 10-in Horn Loaded Cone
HF Subsystem & Loading	1x 2-in Exit Compression Driver on Constant Directivity Horn
System Configuration	3-way, Full Range
Powering Configuration(s)	Triamplified
Recommended High-Pass Frequency (24 dB/Octave)	60Hz
Cabinet Type (shape)	Trapezoidal
Enclosure Materials	Baltic Birch Plywood
Finish	Black Catalyzed Polyurethane
Connectors	1 each male and female AP6
Suspension Hardware	(4) 19-postition Flytracks (2 each top and bottom)
Grill	Vinyl Coated Perforated Steel, Foam Backed
Options	179001 Flyclip with ring 179002 Flyclip with hook Mounting Bracket 255010 Caster Pallet 850

NOMINAL DATA

Frequency Response (Hz)		
±3 db	86Hz to 17kHz	
-10 dB	65Hz	
Axial Sensitivity (dB SPL/1 Watt/1m)		
LF	102	
MF	109	
HF	112	



Impedance (Ohms)

LF	8
MF	8
HF	10

Power Handling, AES Standard (Watts)

LF	1000
MF	400
HF	200

Calculated Maximum Output (dB SPL, @ 1m)

LF Peak	138.0
MF Peak	141.0
HF Peak	141.0
LF Long Term	132.0
MF Long Term	135.0
HF Long Term	135.0

Nominal Coverage Angle / -6 dB points (degrees)

Horizontal	55
Vertical	40

Recommended Complementary Systems

Sub	SB850/SB1000e
-----	---------------

Dimensions	inches	millimeters
	Height	42 1067
Width (Front)	26.375	670
	Width (Rear)	16.5 419
Depth	29.5	749
	Trapezoid Angle	9.5 degrees per side

Weights	pounds	kilograms
	Net Weight	250 113.8
	Shipping Weight	258 117.4





TECHNICAL SPECIFICATIONS KF850EF

DIMENSIONAL DRAWING

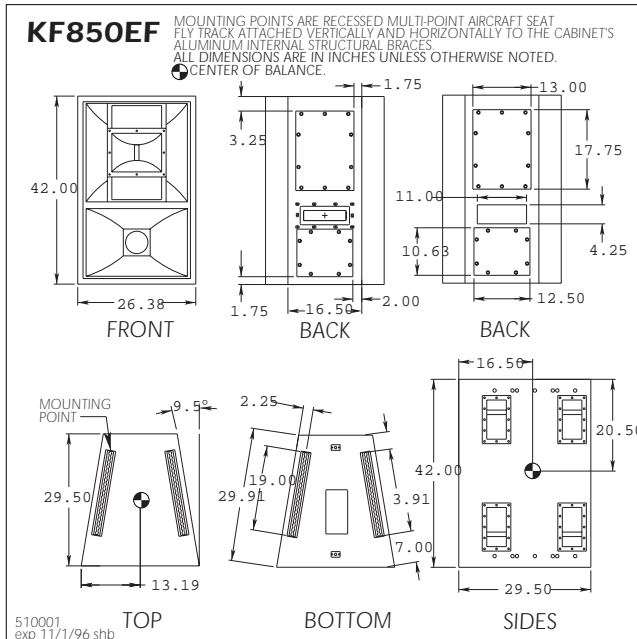

SERVICE ITEMS

LF: Complete Cone Driver:	EAW Part No. 804036
MF: Complete Cone Driver	EAW Part No. 804022
HF: Complete Compression Driver/Tweeter	EAW Part No. 803011
Filter/Crossover Network: Complete Assembly	EAW Part No. 201062

ARCHITECTURAL SPECIFICATIONS

The three-way full range loudspeaker systems shall incorporate a 15-in LF transducer, a 10-in cone MF transducer and a 2-in exit compression driver HF transducer.

The LF driver shall be mounted in a wave guide cavity for optimum low frequency directivity. The MF driver shall be loaded into a midrange horn constructed of 3mm birch plywood reinforced with high density polyurethane foam. The MF horn shall incorporate a phase/displacement plug. The HF driver shall be mounted in the wave guide cavity directly in front of the LF driver and shall be loaded on a constant directivity horn with a nominal coverage pattern of 55° (h) x 40° (v). An acoustical filter shall be installed in the LF waveguide cavity behind the HF section to absorb refracted HF energy. An internal filter network shall provide system equalization.

System frequency response shall vary no more than ± 3 dB from 86 Hz to 17 kHz measured on axis. The low frequency section shall produce a Sound Pressure Level (SPL) of 102 dB SPL on axis at 1 meter with a power input of 1 Watt, and shall be capable of producing a peak output of 138 SPL on axis at 1 meter. It shall handle 1000 Watts of amplifier power (AES Standard) and shall have a nominal impedance of 8 Ohms. The midrange frequency section shall produce a Sound Pressure Level (SPL) of 109 dB SPL on axis at 1 meter with a power input of 1 Watt, and shall be capable of producing a peak output of 141 SPL on axis at 1 meter. It shall handle 400 Watts of amplifier power (AES Standard) and shall have a nominal impedance of 8 Ohms. The high frequency section shall produce a Sound Pressure Level (SPL) of 112 dB SPL on axis at 1 meter with a power input of 1 Watt, and shall be capable of producing a peak output of 141 SPL on axis at 1 meter. It shall handle 200 Watts of amplifier power (AES Standard) and shall have a nominal impedance of 10 Ohms.

The loudspeaker enclosure shall be trapezoidal in shape. It shall be constructed of 15mm thickness void-free cross-grain-laminated Baltic birch plywood and shall employ extensive internal bracing. It shall be finished in black catalyzed polyurethane. Input connectors shall be one each male and female AP6. A total of four 19-position flytracks (2 each top and bottom) shall be provided. The front of the loudspeaker shall be covered with a vinyl coated perforated steel grill backed with open cell foam to protect against dust.

The three-way full range loudspeaker shall be the EAW model KF850EF.