

REV	DESCRIPTION	APVD/DATE
2	REVISED PER ECO #4724 DM 7/31/00.	KFH 9/6/00

NOTES:

1. SYMBOL ● INDICATES MOUNTING POINT, 3/8-16 THREADED HOLE (NUT PLATE).
2. SYMBOL ⊙ INDICATES MOUNTING POINT, 3/8-16 THREADED HOLE (PI ANGLE).
3. SYMBOL ⊕ INDICATES CENTER OF BALANCE.
4. WEIGHT APPROX. 60 LBS.
5. SHIPPING WEIGHTS APPROX. 70 LBS.

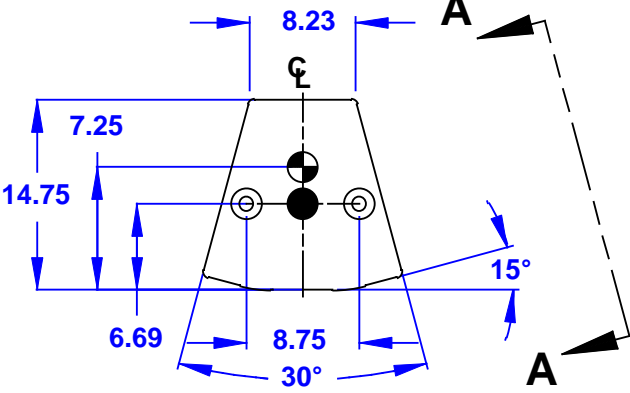

TOP
DIMENSIONS APPLY TO TOP & BOTTOM

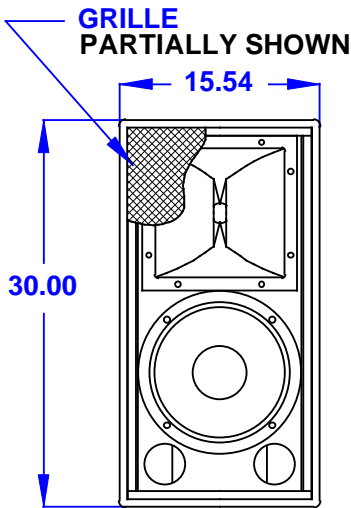

FRONT

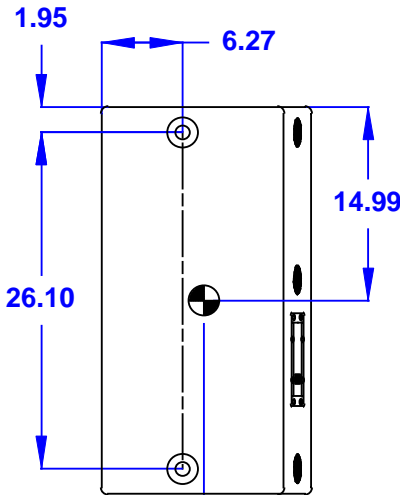

VIEW A-A
DIMENSIONS APPLY TO BOTH SIDES

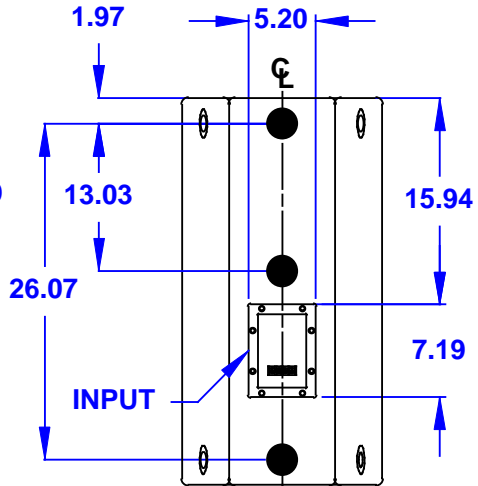

BACK

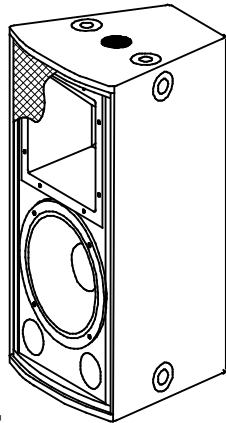

MK2194

DOCUMENT CONTROL PER SPECIFICATION 4.5.201

<p>THIRD ANGLE PROJECTION</p> <p>THIS DRAWING IS THE PROPERTY OF EAW AND SHALL NOT BE COPIED, REPRODUCED, OR USED AS THE BASIS FOR MANUFACTURE OR SALE OF APPARATUS WITHOUT WRITTEN AUTHORIZATION. DO NOT SCALE DRAWING.</p>	<p>UNLESS OTHERWISE SPECIFIED: ALL DIMENSIONS ARE IN INCHES</p> <p>TOLERANCE IN INCHES .XX ± .13 ANGLES ± 1°</p> <p>(X.XX) = REF DIMS NO TOLERANCE IMPLIED</p> <p>T.S.C.=THEORETICAL SHARP CORNER</p> <p>DIMENSIONS ACROSS CENTERLINES TO BE SYMMETRICAL</p>	STATUS: PRODUCTION		<p>EAW EASTERN ACOUSTIC WORKS ONE MAIN STREET WHITINSVILLE, MA 01588 USA</p> <p>TITLE: CABINET/FINISHED/MK2194 [MECHANICAL SPECIFICATION]</p>		
		APPROVALS	DATE		DRAWING NUMBER: 510494	REVISION: 2
		DRAWN: JWB	7/14/97			
		CHECKED: RAS	7/15/97		SHEET 1 OF 1	
		DES ENG: SO	7/25/97			DRAWING NUMBER: 510494
MFG ENG: KRV	7/30/97					