



DESCRIPTION

- Premium Performance
- Application Flexibility

The MK2300 Series of 2-way, high output, trapezoidal loudspeakers are designed as main PA for smaller venues, including houses of worship, auditoriums/theaters, A/V systems, hotel ballrooms, and meeting rooms. The Series is also ideal for distributed or fill purposes in larger venues, including houses of worship, auditorium/theaters, arenas, stadiums, nightclubs, and themed-entertainment complexes.

To meet the design goals for the intended applications, EAW engineers developed a new, high performance, 3-inch voice coil, compression driver mating it to a selection of six different HF horns with patterns from 60° x 45° to 120° x 60°. The horns are as large as the enclosure size allows to maintain consistent directivity throughout the HF passband. A3-inch voice coil, 12 inch LF driver, was designed to complement the sonic character and output of the HF driver. All MK2300 models are carefully voiced to sound similar, permitting diverse horn patterns to be mixed throughout an installation while maintaining the same sonic quality. The results are cleaner, usable, high-fidelity output to significantly higher levels than is normally expected from loudspeakers of this size and price.

Single-amp and bi-amp operating modes are user-selectable. In singleamp mode, the beamwidth-matching passive crossover is designed for even power response through crossover, low power losses, and high power handling. In bi-amp mode a digital signal processor (DSP) is required, providing sophisticated processing to maximize performance. Foam-backed grilles hide the drivers from view for pleasing aesthetics. Thirteen mounting points allow enclosures to be mounted in virtually any configuration. Additional mounting points mate with OmniMount® 120.0 Series or Allen MultiMount-120 brackets. Standard colors are black and white. Other colors can be specified as a special order items. The MK2300 are the smaller companions to the MK5300 Series loudspeakers. Enclosures for both series are the same height facilitating installation where more than one horn pattern and/or type of loudspeaker capability is needed. Six Year Warranty.

¹ To achieve specified performance, the listed external processing with EAW-provided settings is required.

² For recommendations to select power amplifier size refer to : "HOW MUCH AMPLIFIER DO I NEED?" on the EAW web site.

2-WAY FULL-RANGE LOUDSPEAKER 120° x 60°

See *NOTES TABULAR DATA* for details

CONFIGURATION

Subsystem:		
	Transducer	Loading
LF	1x 12 in cone	Vented
HF	1x 1.4 in exit, 3 in voice coil compression driver	Horn-loaded

Operating Mode:

	Amplifier Channels	External Signal Processing
Single-amp	LF/HF	High pass filter
Bi-amp	LF,HF	DSP w/2-way filters

PERFORMANCE ¹

Operating Range:	63 Hz to 15 kHz	
Nominal Beamwidth: (rotatable)		
Horz	120°	
Vert	60°	

Axial Sensitivity (whole space SPL):		
LF/HF	95 dB	63 Hz to 15 kHz
LF	97 dB	63 Hz to 1970 Hz
HF	106 dB	1280 Hz to 15 kHz

Input Impedance (ohms):		
	Nominal	Minimum
LF/HF	8	7.1 @ 180 Hz
LF	8	7 @ 290 Hz
HF	8	8.2 @ 5620 Hz

High Pass Filter: High Pass =>55 Hz, 12 dB/octave Butterworth

Accelerated Life Test: ²		
LF/HF	69 V	600 W @ 8 ohm
LF	69 V	600 W @ 8 ohm
HF	35 V	150 W @ 8 ohm

Calculated Axial Output Limit (whole space SPL):		
	Average	Peak
LF/HF	123 dB	129 dB
LF	125 dB	131 dB
HF	128 dB	134 dB

ORDERING DATA

Description	Part Number
EAW MK2326 2-Way Full-Range Loudspeaker Black	0013385
EAW MK2326 2-Way Full-Range Loudspeaker White	0013751
EAW MK2326 2-Way Full-Range Loudspeaker Black-WP	0013778

Optional Accessories	
Eyebolt/Forged Shoulder (3/8-16 x 1.25 in)	104001
MK2/5000 U-Bracket Black	0007869
MK2/5000 U-Bracket White	0015076

ENCLOSURE

- Material Exterior-grade Baltic birch plywood
- Finish Wear resistant textured black paint
- Grille Powder-coated perforated steel

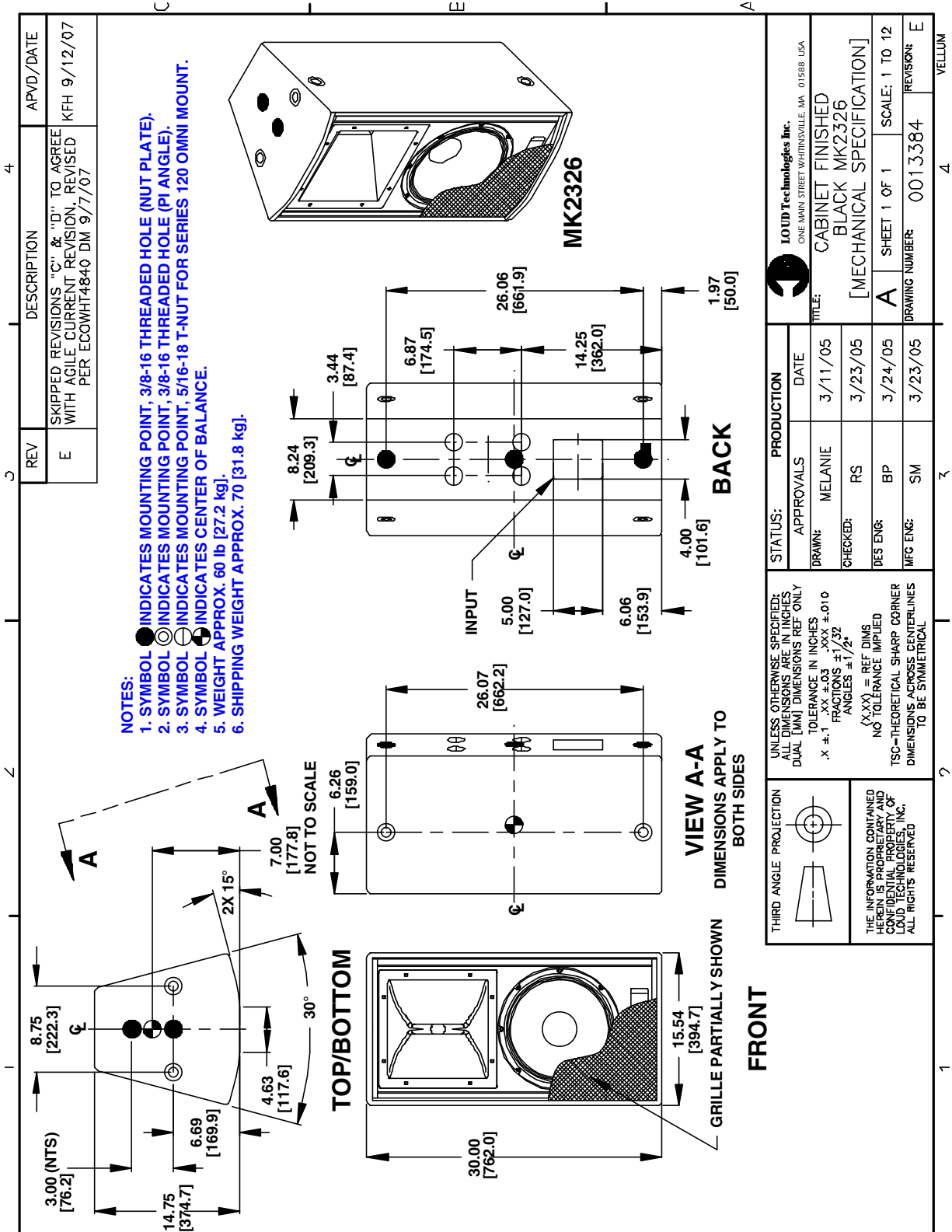

NOTE: This drawing has been reduced. Do not scale.

PERFORMANCE DATA

See *NOTES GRAPHIC DATA* for details

Frequency Response: Processed Multi-Amp

LF = green, HF = black, Complete = blue

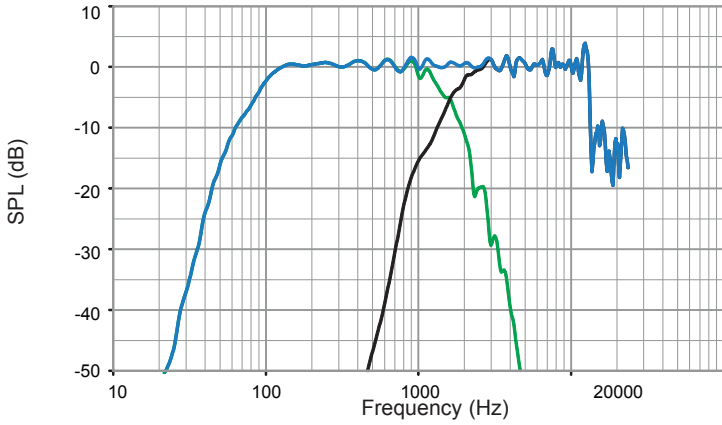

Frequency Response: Unprocessed

LF = green, HF = black, Complete = blue

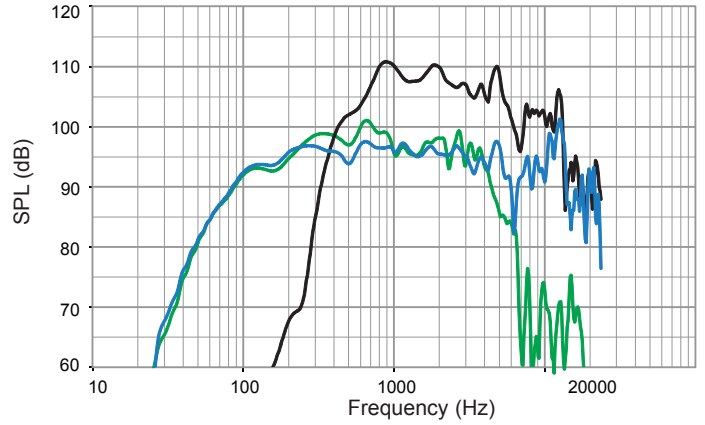

Frequency Response: Digital Signal Processor

LF = green, HF = black

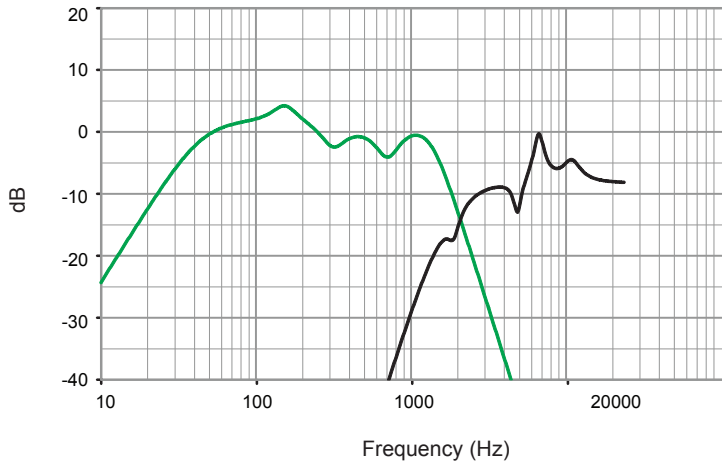

Impedance

LF = green, HF = black, Complete = blue

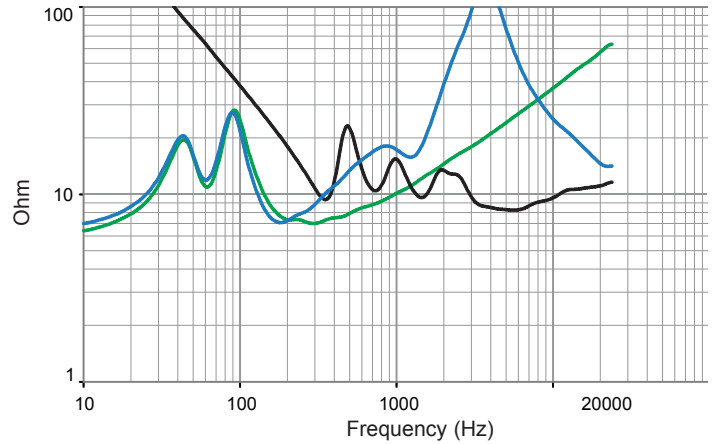

Beamwidth

Horizontal = orange Vertical = black

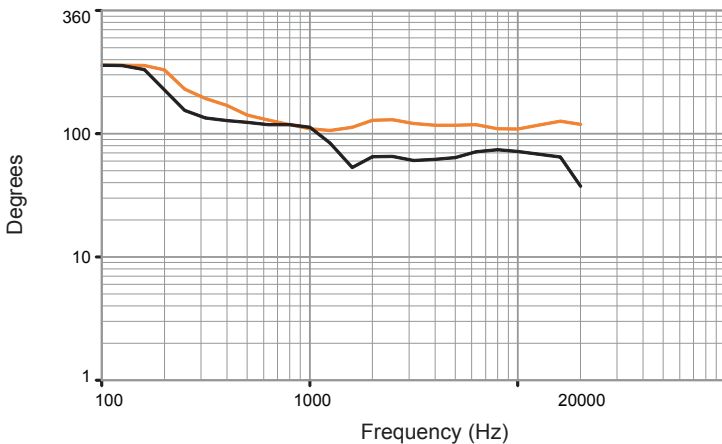

HORIZONTAL POLAR DATA

See *NOTES GRAPHIC DATA* for details

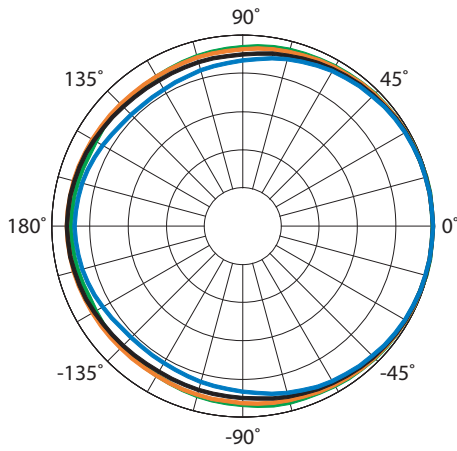

- 100Hz
- 125Hz
- 160Hz
- 200Hz

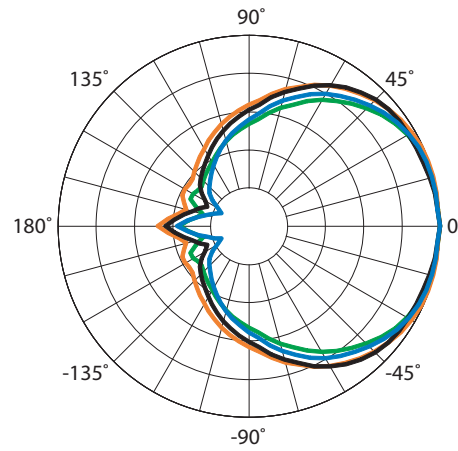

- 1600Hz
- 2000Hz
- 2500Hz
- 3150Hz

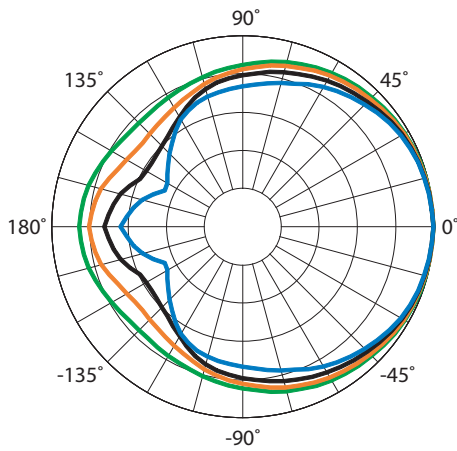

- 250Hz
- 315Hz
- 400Hz
- 500Hz

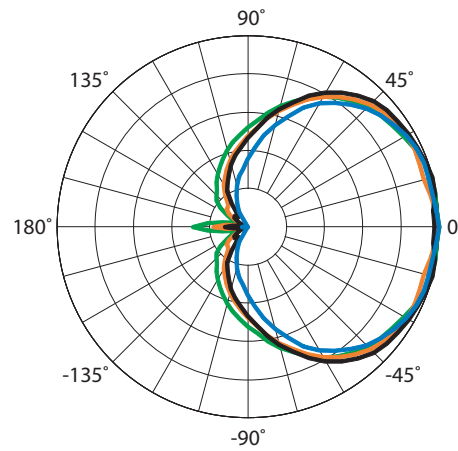

- 4000Hz
- 5000Hz
- 6300Hz
- 8000Hz

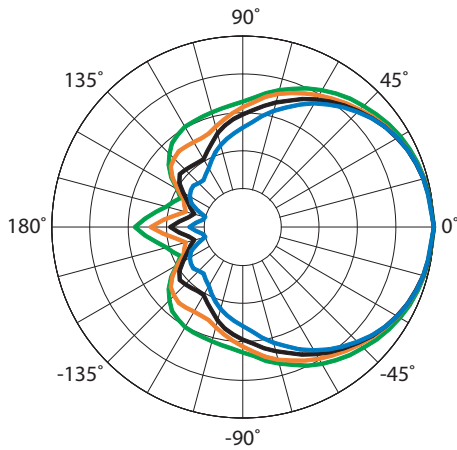

- 630Hz
- 800Hz
- 1000Hz
- 1250Hz

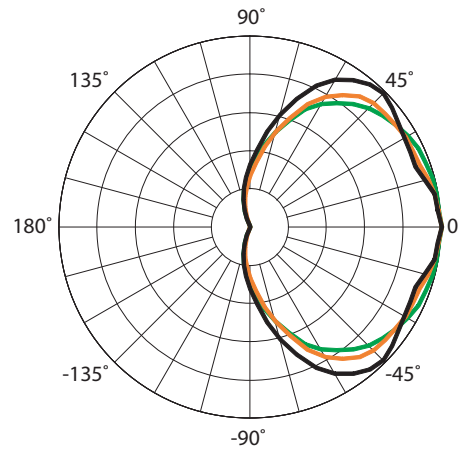

- 10000Hz
- 12500Hz
- 16000Hz

VERTICAL POLAR DATA

See *NOTES GRAPHIC DATA* for details

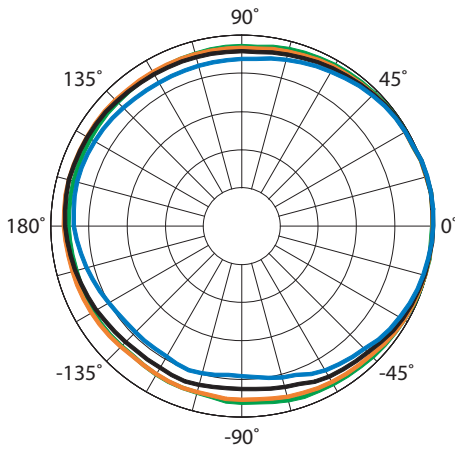

- 100Hz
- 125Hz
- 160Hz
- 200Hz

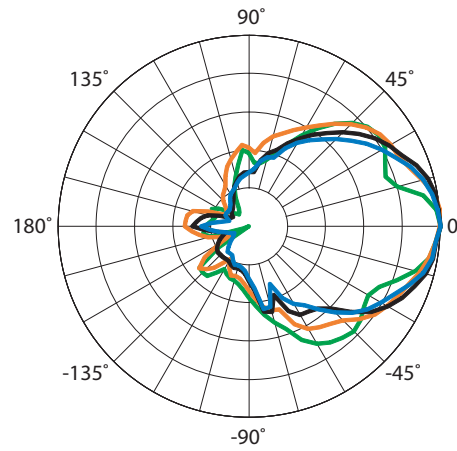

- 1600Hz
- 2000Hz
- 2500Hz
- 3150Hz

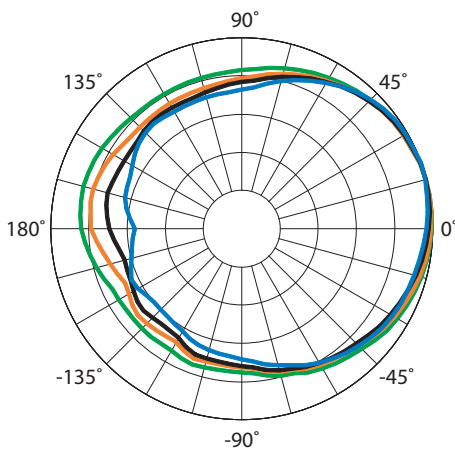

- 250Hz
- 315Hz
- 400Hz
- 500Hz

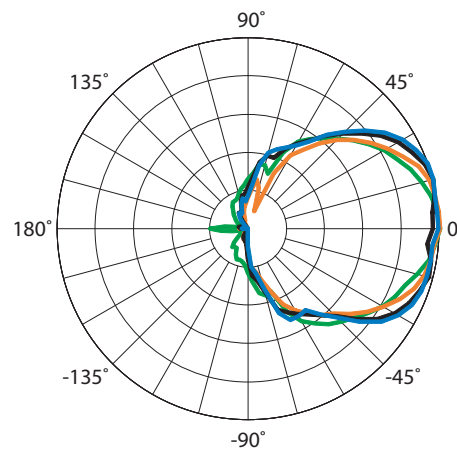

- 4000Hz
- 5000Hz
- 6300Hz
- 8000Hz

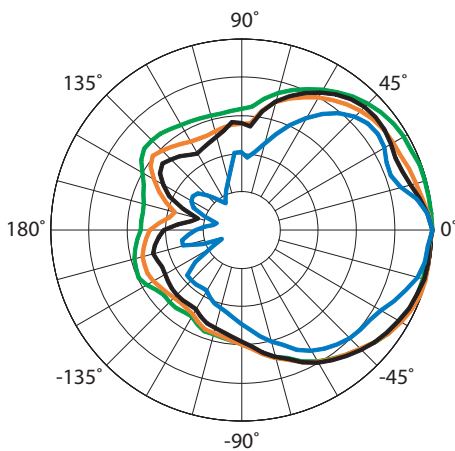

- 630Hz
- 800Hz
- 1000Hz
- 1250Hz

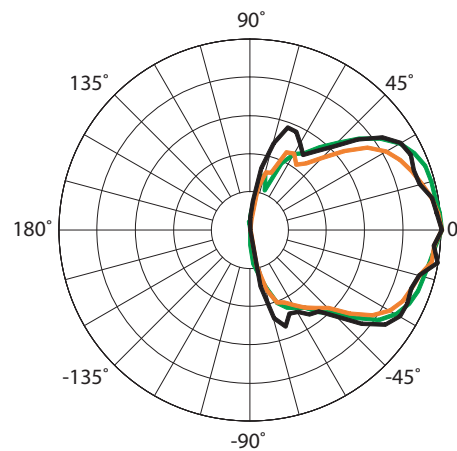

- 10000Hz
- 12500Hz
- 16000Hz

INPUT PANEL

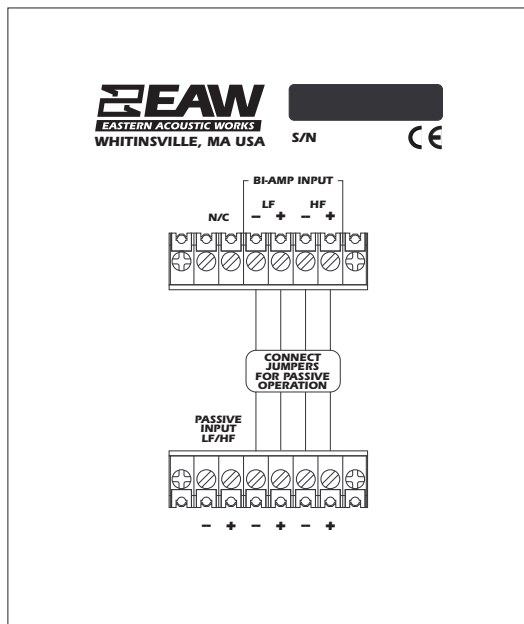

SIGNAL DIAGRAM

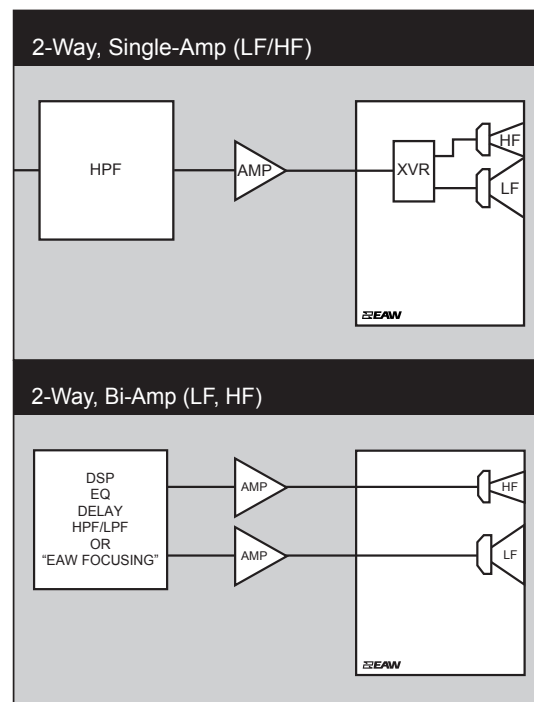

LEGEND

- DSP:** EAW UX8800 Digital Signal Processor –or– Integral Digital Signal Processing for NT products.
- HPF:** High Pass Filter for crossover –or– Recommended High Pass Filter.
- LPF:** Low Pass Filter for crossover.
- LF/MF/HF:** Low Frequency / Mid Frequency / High Frequency.
- AMP:** User Supplied Power Amplifier –or– Integral Amplifier for NT products.
- XVR:** Passive LPFs, HPFs, and EQ integral to the loudspeaker.
- EAW Focusing:** Digital Signal Processor capable of implementing EAW Focusing.

NOTES

TABULAR DATA

1. **Measurement/Data Processing Systems:** Primary - FChart: proprietary EAW software; Secondary - Brüel & Kjær 4132.
2. **Microphone Systems:** Earthworks M30; Brüel & Kjær 4133
3. **Measurements:** Dual channel FFT; length: 32 768 samples; sample rate: 48 kHz; logarithmic sine wave sweep.
4. **Measurement System Qualification** (includes all uncertainties): SPL: accuracy +/-0.2 dB @ 1 kHz, precision +/-0.5 dB 20 Hz to 20 kHz, resolution 0.05 dB; Frequency: accuracy +/-1 %, precision +/-0.1 Hz, resolution the larger of 1.5 Hz or 1/48 octave; Time: accuracy +/-10.4 µs, precision +/-0.5 µs, resolution 10.4 µs; Angular: accuracy +/-1°, precision +/-0.5°, resolution 0.5°.
5. **Environment:** Measurements time-windowed and processed to eliminate room effects, approximating an anechoic environment. Data processed as anechoic or fractional space, as noted.
6. **Measurement Distance:** 7.46 m. Acoustic responses represent complex summation of the subsystems at 20 m. SPL is referenced to other distances using the Inverse Square Law.
7. **Enclosure Orientation:** For beamwidth and polar specifications, as shown in Mechanical Specification drawing.
8. **Volts:** Measured rms value of the test signal.
9. **Watts:** Per audio industry practice, "loudspeaker watts" are calculated as voltage squared divided by rated nominal impedance. Thus, these are not True Watt units of energy as defined by International Standard.
10. **SPL:** (Sound Pressure Level) Equivalent to the average level of a signal referenced to 0 dB SPL = 20 microPascals.
11. **Subsystem:** This lists the transducer(s) and their acoustic loading for each passband. Sub = Subwoofer, LF = Low Frequency, MF = Mid Frequency, HF = High Frequency.
12. **Operating Mode:** User selectable configurations. Between system elements, a comma (,) = separate amplifier channels; a slash (/) = single amplifier channel. DSP = Digital Signal Processor. IMPORTANT: To achieve the specified performance, the listed external signal processing must be used with EAW-provided settings.
13. **Operating Range:** Range where the processed Frequency Response stays within -10 dB SPL of the power averaged SPL within this range; measured on the geometric axis. Narrow band dips are excepted.
14. **Nominal Beamwidth:** Design angle for the -6 dB SPL points, referenced to 0 dB SPL as the highest level.
15. **Axial Sensitivity:** Power averaged SPL over the Operating Range with an input voltage that would produce 1 W at the nominal impedance; measured with no external processing on the geometric axis, referenced to 1 m.
16. **Nominal Impedance:** Selected 4, 8, or 16 ohm resistance such that the minimum impedance point is no more than 20% below this resistance over the Operating Range.
17. **Accelerated Life Test:** Maximum test input voltage applied with an EIA-426B defined spectrum; measured with recommended signal processing and Recommended Protection Filter.
18. **Calculated Axial Output Limit:** Highest average and peak SPLs possible during the Accelerated Life Test. The Peak SPL represents the 2:1 (6 dB) crest factor of the Life Test signal.
19. **High Pass Filter:** This helps protect the loudspeaker from excessive input signal levels at frequencies below the Operating Range.

GRAPHIC DATA

1. **Resolution:** To remove insignificant fine details, 1/12 octave cepstral smoothing was applied to acoustic frequency responses and 1/3 octave cepstral smoothing was applied to the beamwidth and impedance data. Other graphs are plotted using raw data.
2. **Frequency Responses:** Variation in acoustic output level with frequency for a constant input signal. Processed: normalized to 0 dB SPL. Unprocessed inputs: 2 V (4 ohm nominal impedance), 2.83 V (8 ohm nominal impedance), or 4 V (16 ohm nominal impedance) referenced to a distance of 1 m.
3. **Processor Response:** The variation in output level with frequency for a constant input signal of 0.775 V = 0 dB reference.
4. **Beamwidth:** Average angle for each 1/3 octave frequency band where, starting from the rear of the loudspeaker, the output first reaches -6 dB SPL referenced to 0 dB SPL as the highest level. This method means the output may drop below -6 dB SPL within the beamwidth angle.
5. **Impedance:** Variation in impedance magnitude, in ohms, with frequency without regard to voltage/current phase. This means the impedance values may not be used to calculate True Watts (see 9 above).
6. **Polar Data:** Horizontal and vertical polar responses for each 1/3 octave frequency band 100 Hz to 16 kHz or Operating Range.