



TECHNICAL SPECIFICATIONS SB625P

DESCRIPTION

A dedicated subwoofer system with 2x 15-in transducers in a vented rectangular enclosure. Each driver is in its own optimally vented subenclosure.

APPLICATIONS

The SB625 is optimized for permanent installation as a sub bass complement to medium format MH/CH-BH/BV arrays. Tuned enclosure venting extends LF response and minimizes driver strain. MX Series processors extend LF response and safeguard against cone excursion damage. Comprehensive mounting/suspension points. Six year warranty.

Applications include:

- Band PA
- Corporate Events
- Small HOW's
- Dance Clubs
- Live Music Clubs

DESCRIPTIVE DATA

Part Number	999137
Product Group	M
Components & Loading	2x 15-in Vented
System Configuration	Dedicated Subwoofer
Recommended High-Pass Frequency (24 dB/Octave)	25Hz
Cabinet Type (shape)	Rectangular
Enclosure Materials	Baltic Birch Plywood
Finish	Black Catalyzed Polyurethane
Connectors	4-Terminal Barrier Strip
Suspension Hardware	(16) 3/8"-16 threaded mounting/suspension points (4 each top, bottom, sides)
Grill	Vinyl Coated Perforated Steel



NOMINAL DATA

Frequency Response (Hz)	±3 db	33Hz (44Hz w/out CCEP) to 200Hz	
	-10 dB	30Hz (34Hz w/out CCEP)	
Axial Sensitivity (dB SPL/1 Watt/1m)	98		
	Impedance (Ohms)		
			4 or 2x 8
Power Handling (Watts)	AES Standard		
	2000		
Calculated Maximum Output (dB SPL, @ 1m)	Peak		
	137.0		
	Long Term		
			131.0
Recommended Complementary Systems			
Full Range		KF650e/KF695e	
Dimensions	inches		millimeters
	Height	33.25	845
	Width	19.75	502
	Depth	24.625	625
Weights	pounds		kilograms
	Net Weight	130	59.2
	Shipping Weight	138	62.8





TECHNICAL SPECIFICATIONS SB625P

DIMENSIONAL DRAWING

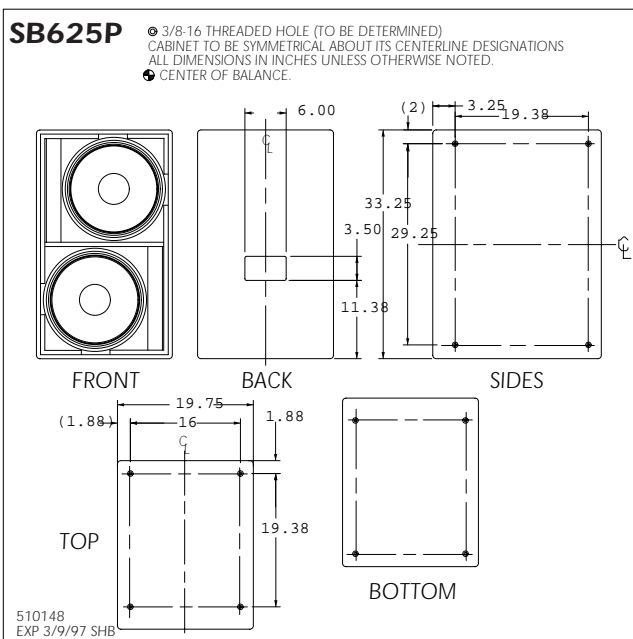

SERVICE ITEMS

Sub: Complete Cone Driver

EAW Part No. 804052

Filter/Crossover Network: Complete Assembly

EAW Part No. 201203

ARCHITECTURAL SPECIFICATIONS

The sub bass loudspeaker systems shall incorporate 2x 15-in LF transducers mounted in separate vented subenclosures tuned for optimum low frequency response.

System frequency response shall vary no more than ± 3 dB from 33 Hz to 200 Hz measured on axis with appropriate signal processing. The loudspeaker shall produce a Sound Pressure Level (SPL) of 98 dB SPL on axis at 1 meter with a power input of 1 Watt, and shall be capable of producing a peak output of 137 SPL on axis at 1 meter. The loudspeaker shall handle 2000 Watts of amplifier power (AES Standard) and shall have a nominal impedance of 4 (2x 8) Ohms.

The loudspeaker enclosure shall be rectangular in shape. It shall be constructed of 15mm thickness void-free cross-grain-laminated Baltic birch plywood and shall employ extensive internal bracing. It shall be finished in black catalyzed polyurethane. Input connectors shall be 2-terminal barrier strip. A total of sixteen 3/8"-16 threaded mounting/suspension points (4 each top, bottom, sides) shall be provided. The front of the loudspeaker shall be covered with a vinyl coated perforated steel grill.

The sub bass loudspeaker shall be the EAW model SB625P.