

EA EAW[®]

EASTERN ACOUSTIC WORKS



UXA Series Owner's Manual

Table of Contents

COMPLIANCE	5
FOR CUSTOMERS IN EUROPE.....	5
FOR CUSTOMERS IN THE USA.....	6
FOR CUSTOMERS IN CANADA.....	7
Thanks and Unpacking	8
Unpacking the EAW UXA Series Amplifier	8
INSTALLATION INSTRUCTIONS	9
Mechanical Installation	9
AC Power Connection	10
EAW UXA.....	11
Introduction and Key Features.....	11
Introduction	11
Key Features.....	11
Audio Connections	12
Input Connections	12
Using unbalanced connections	13
Amplifier Output Connections.....	14
Load Matching	14
Panel Layouts	15
Operation	17
Starting up the unit.....	17
Navigation.....	18
The Home Page	19
Input.....	19
AES3 Inputs	19
Dante Inputs.....	20
Automatic Input Selection (Fallover).....	20
Gain and Polarity.....	21
Delay.....	21
High Pass Filter	21
Parametric Equalization	21
FIR Linear Phase Equalization.....	21
Parametric Filters.....	21
Routing	21

Output.....	22
Gain and Polarity.....	22
Delay.....	22
High and Low pass Filters.....	22
Parametric Equalization.....	22
Limiters.....	22
Bridge.....	22
Routing.....	23
Utility Pages.....	23
Screen Contrast.....	23
Current Ethernet IP Address.....	23
IP Mode.....	23
IP Static.....	23
Bandwidth Units.....	23
ECO.....	24
External Breaker Protection (EBP).....	24
Ethernet.....	24
Ethernet configurations.....	24
DHCP.....	24
AUTO-IP.....	24
Static-IP.....	25
AUX Port.....	25
Secure Mode.....	25
Protection Systems.....	25
Summary of Protection Indication.....	26
Incident Reporting.....	26
Fault Relay.....	26

IMPORTANT SAFETY INSTRUCTIONS



The lightning bolt triangle is used to alert the user to the risk of electric shock.



The exclamation point triangle is used to alert the user to important operating or maintenance instructions.

1. Read these instructions.
2. Keep these instructions.
3. Heed all warnings.
4. Follow all instructions.
5. Do not use this apparatus near water.
6. Clean only with dry cloth.
7. Do not block any ventilation openings. Install in accordance with the manufacturer's instructions.
8. Do not install near any heat sources such as radiators, heat registers, stoves or other apparatus (including amplifiers) that produce heat.
9. Do not defeat the safety purpose of the polarized or grounding type plug. A polarized plug has two blades with one wider than the other. A grounding type plug has two blades and a third grounding prong. The wide blade or the third prong are provided for your safety. If the provided plug does not fit into your outlet, consult an electrician for replacement of the obsolete outlet.
10. Protect the power cord from being walked on or pinched particularly at plugs, convenience receptacles and the point where they exit from the apparatus.
11. Only use attachments / accessories specified by the manufacturer.
12. Use only with the cart, tripod, bracket or table specified by the manufacturer, or sold with the apparatus. When a cart is used, use caution when moving the cart / apparatus combination to avoid injury from tip-over.
13. Unplug this apparatus during lightning storms or when unused for long periods of time.
14. Refer all servicing to qualified service personnel. Service is required when the apparatus has been damaged in any way, such as power-supply cord or plug damaged, liquid has been spilled or objects have fallen into the apparatus, this apparatus has been exposed to rain or moisture, does not operate normally, or has been dropped.
15. The apparatus shall not be exposed to dripping or splashing and no objects filled with liquids, such as vases, shall be placed on the apparatus.
16. Permanent disconnection from the mains supply is to be achieved by removing the supplied cord connector from the back of the unit. This connector must remain readily operable.



WARNING

Do not remove any covers, loosen any fixings or allow items to enter any aperture.



WARNING

This product must be grounded. Use only a flexible cable or cord with a green and yellow core which must be connected to the protective earthing terminal of a suitable mains plug or the earthing terminal of the installation.



WARNING

The rear of the product may get hot. Avoid direct skin contact during operation and for at least 5 minutes after power has been isolated.



WARNING

This product is designed for permanent installation. It must be fitted in to a 19" rack enclosure and not operated unless so installed. The rack enclosure must allow free air movement through the product.

COMPLIANCE FOR CUSTOMERS IN EUROPE

This product complies with both the LVD (electrical safety) 73/23/EEC and EMC (electromagnetic compatibility) 89/336/EEC directives issued by the commission of the European community.

Compliance with these directives implies conformity with the following European standards:

EN60065 8th Edition	Product safety
EN55032-2012	EMC emissions
EN55103-2-2009	EMC immunity

This product is intended for the following electromagnetic environments: E1, E2; E3 & E4.



THIS PRODUCT MUST BE GROUNDED. Use only a flexible cable or cord with a green and yellow core which must be connected to the protective earthing terminal of a suitable mains plug or the earthing terminal of the installation. The cord must be a maximum of 2m long, have a 4.0mm² CSA, a 300/500V rating and comply with EN50525-2-11 / H05W-F (105oC).

FOR CUSTOMERS IN THE USA

This product complies with UL60065 8th edition.

DECLARATION OF CONFORMITY WITH FCC RULES

We, EAW of One Main Street, Whitinsville, MA 01588, USA, declare under our sole responsibility that this family of devices, complies with Part 15 of the FCC Rules. Operation is subject to the following two conditions: (1) this device may not cause harmful interference, and (2) this device must accept any interference received, including interference that may cause undesired operation.

FEDERAL COMMUNICATIONS COMMISSION NOTICE

An example of this equipment has been tested and found to comply with the limits for a Class A digital device, pursuant to Part 15 of the FCC Rules. These limits are designed to provide reasonable protection against harmful interference in a residential and commercial installation.

This equipment generates, uses, and can radiate radio frequency energy, and if not installed and used in accordance with the instructions, may cause harmful interference to radio communications. However, there is no guarantee that interference will not occur in a particular installation. If this equipment does cause harmful interference to radio or television reception, which can be determined by turning the equipment off and on, the user is encouraged to try and correct the interference by one or more of the following measures:

- Reorient or relocate the receiving antenna.
- Increase the distance between the equipment and the receiver.
- Connect the equipment to an outlet on a circuit different from that to which the receiver is connected.
- Consult the dealer or an experienced radio/TV technician for help.

FCC Caution: Any changes or modifications not expressly approved by the party responsible for compliance could void the user's authority to operate this equipment.



THIS PRODUCT MUST BE GROUNDED. Use only a flexible cable or cord with a green or green / yellow core which must be connected to the protective earthing terminal of a suitable mains plug or the earthing terminal of the installation. The cord must be a maximum of 6' long, be 12AWG, 105oC have a rating SJ, SJT, SJE or 300/500V H05W-F and be marked VW-1.

FOR CUSTOMERS IN CANADA

This product complies with CA /CSA C22.2 No.60065-03
Ce produit est conforme avec CA /CSA C22.2 No.60065-03

DECLARATION OF CONFORMITY WITH CANADIAN ICES-003

This Class A digital apparatus complies with Canadian ICES-003.

Cet appareil numérique de la classe A est conforme à la norme NMB-003 du Canada.



THIS PRODUCT MUST BE GROUNDED. Use only a flexible cable or cord with a green or green / yellow core which must be connected to the protective earthing terminal of a suitable mains plug or the earthing terminal of the installation. The cord must be a maximum of 6' long, be 12AWG, 105oC have a rating SJ, SJT, SJE or 300/500V H05W-F and be marked VW-1.

Thanks and Unpacking

Thank you for choosing a EAW UXA Series Advanced System Amplifier for your application. Please spare a little time to study the contents of this manual, so that you obtain the best possible performance from this unit.

All EAW products are carefully engineered for world-class performance and reliability.

If you would like further information about this or any other EAW product, please contact us. We look forward to helping you in the near future.

Unpacking the EAW UXA Series Amplifier

After unpacking the unit please check carefully for damage. If damage is found, please notify the carrier concerned at once. You, the consignee, must instigate any claim. Please retain all packaging in case of future re-shipment.

INSTALLATION INSTRUCTIONS

Mechanical Installation

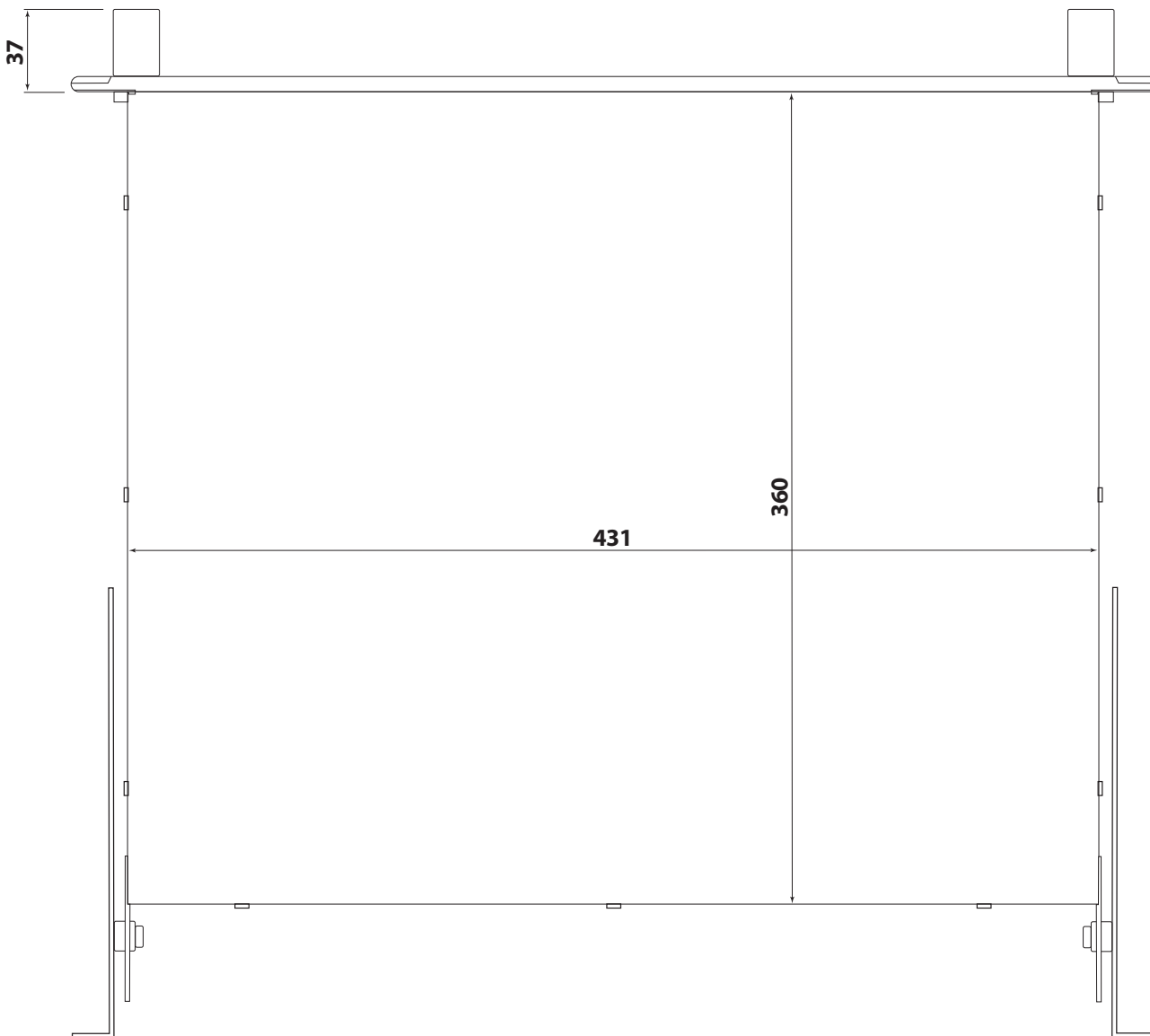
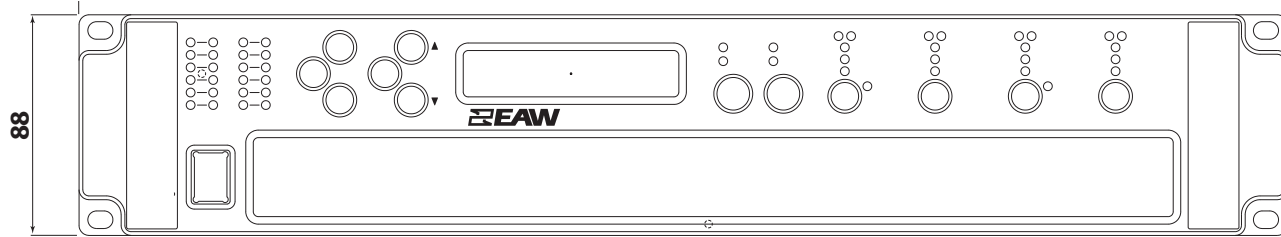

The UXA Series Amplifier must only be operated when mounted in a standard 19" rack enclosure.

Where the amplifier is used in a fixed installation, as long as the bottom unit is supported and there are no gaps between units, it is acceptable to use only the front panel 19" rack mounting points when fitting it in a standard rack enclosure. If the amplifier is mounted in a mobile rack it is important that the rear is supported with a rear

rack mounting kit part number 2050314, included with every amplifier. Damage caused by insufficient support is not covered by the manufacturer's warranty.

To prevent damage to the front panel it is recommended that plastic cups or washers are fitted underneath the rack mounting bolt heads.

It is possible to mount multiple UXA Series amplifiers without ventilation gaps between them but it is essential that an unobstructed flow of clean air is available from the front of the unit to the rear.

General

The amplifier should never be exposed to rain or moisture during operation or storage. If the unit does come into contact with moisture, remove the AC power cord immediately and leave it in a dry and warm location.

Note that when any equipment is taken from a cold location into a warm humid one, condensation may occur inside the device. Always allow time for the equipment to attain the same temperature as its surrounding environment before connecting the AC power cord.

It is the responsibility of the user to ensure that dirt, liquids and vapour from theatrical smoke and fog machines is not ingested by the amplifier. Damage so caused is not covered by the manufacturer's warranty.

Cooling

It is important that neither the air intakes on the front of the unit or the exhaust vents at the rear are obstructed. Steps must also be taken to ensure that hot air does not continually circulate through the amplifiers from the back of the rack to the front.

The air intake filter must be cleaned regularly with warm water and a little detergent to ensure unrestricted airflow. The filter can be removed without the use of tools by gently pulling it out of its aperture. When refitting ensure that it is thoroughly dry and that there are no areas of the grille not covered by the filter element. Operating the amplifier without the air intake filter will invalidate the manufacturer's warranty.

AC Power Connection

The amplifier utilizes a 32A Neutrik PowerCon™ type locking AC power connector. Use only an AC power cord correctly terminated with a genuine Neutrik™ PowerCon™. It is the responsibility of the user to ensure that all wiring is performed by a qualified person in accordance with all local regulations.

The amplifiers are designed to operate on 115V 60Hz or 230V 50 Hz nominal AC power, automatically configuring themselves at switch on. Note that although the amplifiers will operate when the mains supply is within the range specified in this document, various specifications will only be met when the unit is operated at the stated nominal voltages.

EAW UXA Introduction and Key Features

Introduction

The EAW UXA Series Advanced System Amplifier represents current state-of-the-art technology in several areas. This product is the result of several years of research, from which many advances in switched mode power technologies and ever finer detail in signal processing have stemmed. Taking advantage of the latest advances in analog to digital conversion technologies, the unit achieves performance levels among the very best that engineering permits.

Below is a list of key features, followed by some information on the major advanced features of the product.

Key Features

- Four/Eight channels of sonically pure Class D amplification
- Very high power density - packs four channels or eight channels and 10kW into just 2U of rack space
- Packed with robust protection and monitoring systems to keep the show going
- External Breaker Protection (EBP) limits the current draw to prevent breakers opening
- EAW minimal signal path design
- Class leading sonic performance achieved by the use of state of the art Amplifier technologies and highly advanced DSP algorithms
- 48kHz sampling frequency
- Rotary encoders, illuminated buttons and graphical display provide a rapid, intuitive and user-friendly control interface
- High speed Ethernet communications supporting DHCP, static-IP and auto-IP and direct connection to a computer
- Linear phase HF system EQ profiling which provides perfect integration between enclosures
- Dante audio networking with automatic fall over to Analog or AES3
- AES3 inputs

What is a Greybox?

A Greybox is a file that includes everything you need to get optimal performance from an EAW loudspeaker. 'White' component that is user accessible. 'Black' component that is EAW-provided and locked down. Mix together = Grey.

Greyboxes include:



Crossover Settings

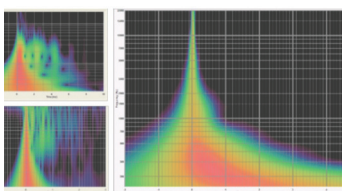

EAW Focusing

By deploying advanced signal processing EAW Focusing corrects for mechanically induced anomalies in the loudspeakers acoustic system and provides a pure impulse response. This means the sound you hear is true to the original version free from time smear created by intra-cabinet reflections.

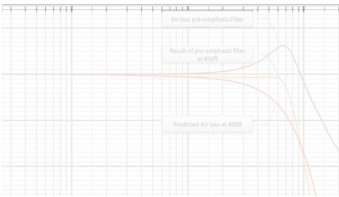

Air Loss Pre-emphasis Filter

A distance, temperature and humidity-dependent air loss pre-emphasis filter improves high frequency projection by correcting for expected air losses for longer distances.

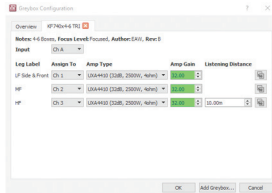

Easy Configuration

Just enter the loudspeaker model and amplifier you are using in the Greybox setup window. Resolution automatically applies the Greybox settings and optimizes the entire system in seconds.

Audio Connections

Input Connections

For each input channel there is a female XLR connector for analog inputs. There is also one female XLR for one stream (two channels) of AES3 digital audio. Note that only two channels of AES3 digital audio are available. The Dante permits more channels of Digital Audio inputs.

The HOT, or + connection should be made to pin 2 of the XLR connector.

The COLD, or - connection should be made to pin 3 of the XLR connector.

Pin 1 of the XLR connectors is internally connected to the chassis. The shield of the input cable should always be connected Pin 1 of the XLR to ensure that EMC performance and regulations are met.

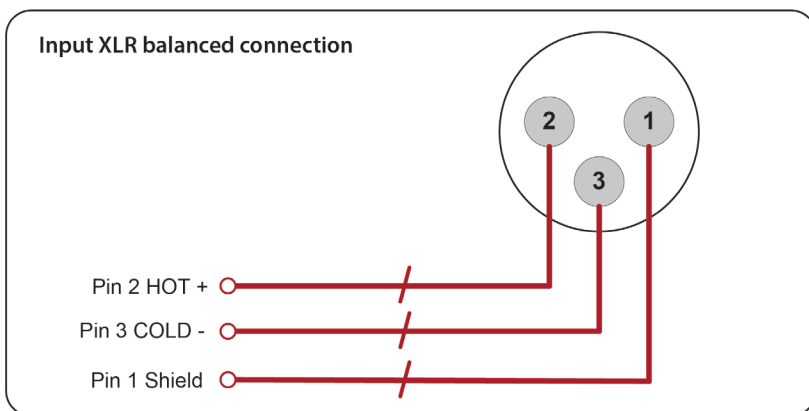

Using unbalanced connections

Please note that the use of unbalanced connections is not recommended, however when connecting the amplifier to an unbalanced audio source, the signal conductor should be connected to XLR pin 2. The 'Cold' conductor or cable screen should be connected to XLR pin 1 with a short connection made between pin 1 and pin 3.

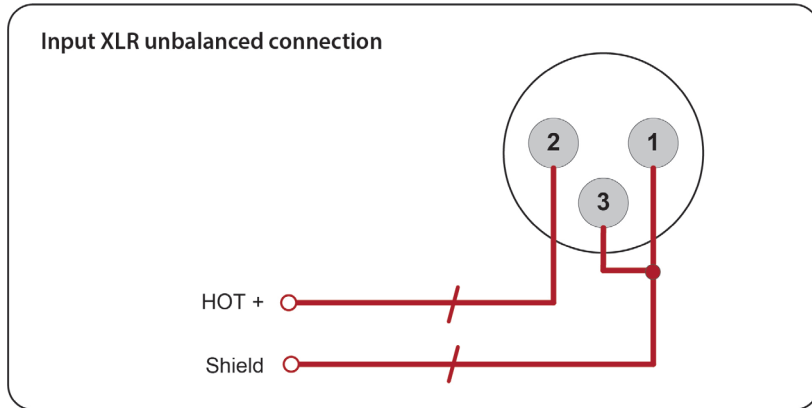

Amplifier Output Connections



Note : The UXA4406, UXA4410 and UXA4810 series amplifiers can produce high voltages at their outputs. Always use genuine Neutrik NL4 connectors. Un-bridged outputs must use Class 2 or class 3 wiring. Bridged channel pairs must use Class 3 wiring. Custom wiring must only be performed by qualified personnel.

The UXA4406 and UXA4410 amplifier is fitted with one NL4 connector per amplifier channel.. The appropriate conductor terminations are shown below and on the rear panel of the unit.

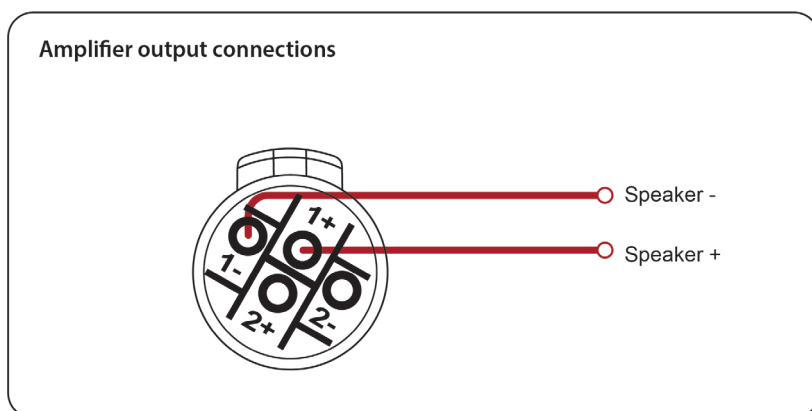

Additionally, the channel 2 output is duplicated on the NL4 connector for amplifier channel 1 for Bi-Amp wiring. Similarly, the channel 4 output is duplicated on the NL4 connector for amplifier channel 3. This can be useful for making a connection to two loudspeakers with one 4-core cable (i.e. Bi-Amp).

On the UXA4810 model, all outputs are Bi-Amp; each NL4 connector carries two amplifier outputs – Channels 1&2, Channels 3&4, Channels 5&6 and Channels 7&8.

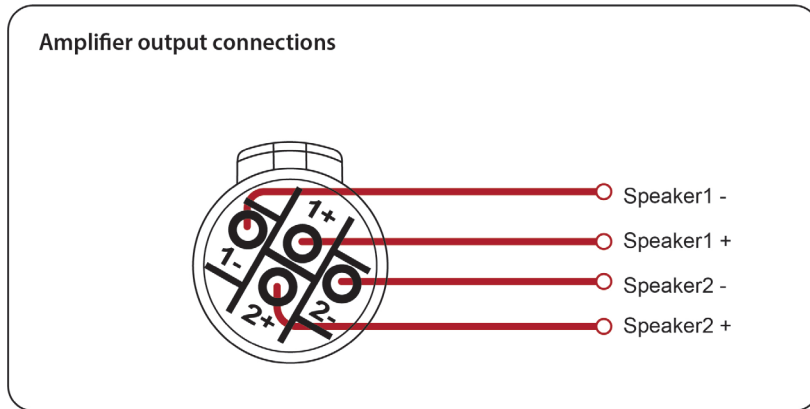

In addition, the channel 1 or channel 3 connector (all the NL4 connectors on the UXA4810 model) can also be used if the pair of amplifier channels is being operated in bridged mode.

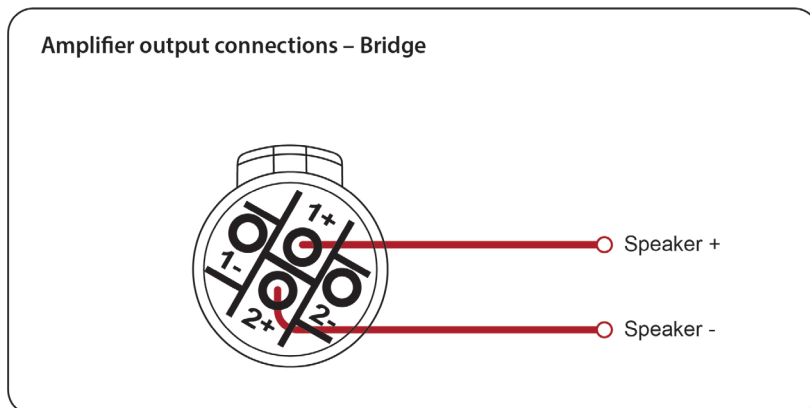

More than one speaker can be connected to each channel provided the total impedance per channel is not less than 2 ohms. In bridged mode the minimum total impedance should not be less than 4 ohms.

Load Matching

Each output of the device can be optimised to drive either a low impedance load (e.g. 2, 4 or 8 Ohms), or a Constant Voltage (C.V.) using the Load parameter in the Output menu. There are several C.V. settings (25V, 70V and 100V Line) which determine the maximum RMS voltage that the amplifier will produce. Select the one which is appropriate for the installation. A number of low impedance settings (depending on the model) are also available. Although it is not critical that this setting matches the impedance of the connected load, this will maximise the power that is available for the load.

Panel Layouts

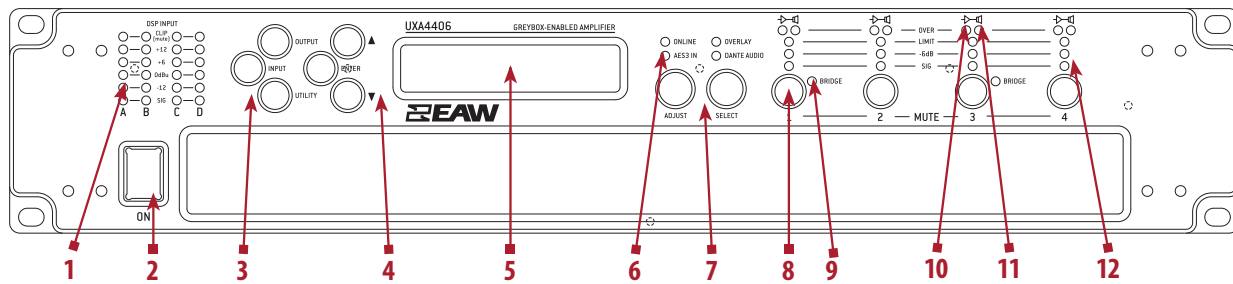

(The UXA4406 or UXA4410 is illustrated. The UXA4810 is similar, but with more output indicators and mute buttons)

1. **Input Signal Indicators**– A set of five indicators show “Sig”, “-12”, “0dBu”, “+6” and “+12” and “Clip (mute)” for each of the DSP inputs “A” “B” “C” “D”. The signal present indicators operate at approximately –40 dBu. The Clip/mute indicators warn the user of input overload and operate at 1dB before clip. This indicator also shows a muted input.
2. **Power Switch**– Applies mains power to the device. If the device has entered Sleep mode, it may be woken up again either from the EAW Resolution software application, or by switching this switch off, then on again.
3. **Menu Buttons**– There are three buttons to determine which section of the device to view or edit. The <OUTPUT> button displays pages of parameters associated with a particular output channel. The <INPUT> button displays pages of parameters associated with a particular input socket or input DSP channel. Pressing <INPUT> or <OUTPUT> buttons repeatedly will scroll through the inputs/outputs of the device. After the last channel, navigation returns to the Home screen. The <UTILITY> button displays pages of miscellaneous parameters not associated with any particular channel. Whilst in Edit mode, one of these three buttons will be illuminated. They are mutually exclusive – pressing one of the buttons will deselect any others that are active. Pressing Utils will escape back to the Home screen.
4. **Page Selection Buttons**– When one of the buttons <INPUT>, <OUTPUT> or <UTILITY> is illuminated, the up <P> and down <Q> arrows will also illuminate, informing the user that these buttons may be used to scroll through the various pages of parameters that may be viewed and edited. The <ENTER> button is used to confirm an operation. It will illuminate when the user is being invited to press it. It will flash when warning the user that pressing this button will activate an important function.
5. **Graphical Display**– This will show the Home screen; a useful overview of channel allocation. On most pages the currently selected channel and parameter information is displayed on the upper part of the screen and the parameter value on the lower part of the screen; this can also optimise the viewing angle.
6. **Status Indicators**– The “OVERLAY” indicator is not currently used. The <DANTE AUDIO> indicator illuminates when one or more of the inputs is using a dante source. The “ONLINE” indicator has three states: *Off*– the unit is offline and not connected to a computer or network. *Flashing*– the unit is searching for an IP address; if the unit does not find an IP address the unit will assign itself an IP address automatically and the indicator will stop flashing. *On*– the unit is online and connected with software. IP settings can be viewed or changed within the <UTILITY> pages. The “AES3 IN” indicator illuminates when one or more of the inputs is using an AES3 source.
7. **Parameter Encoders**– Two velocity sensitive parameter encoders are used to adjust parameters shown on the display. Up to three parameters at a time are displayed on the screen. The parameter name is shown above the parameter value in each of the three screen sections. Use SELECT to highlight the parameter, then ADJUST to change it.
8. **Bridge Indicator**– This will illuminate when the channel pair is in Bridge mode. The controls for the left channel of the pair will determine the settings. See *Bridge Mode*
9. **Mute Buttons**– DSP output mute status is indicated and controlled by an illuminated button for each channel. These flash when the entire unit is muted from the AUXA port or from EAW Resolution software Mute-All, or if this channel has been muted by the protection systems.
10. **Amplifier Indicator**– This indicates when the amplifier protection systems are reducing the gain to keep the parameters of the amplifier within specification, or when that the channel is clipping.
11. **Driver Indicator**– This indicates the output limiter is engaged.
12. **Limiter Indicators**– The output indicators show the status of the limiter and output level. The level indicated is that before the limiter, referenced to the limiter threshold. The <SIG> indicator shows when a signal is present on the output. The second indicator <-6dB> shows that the signal has reached 6dB below the limiter threshold. The third <LIMIT> indicator indicates that the threshold of that output channel has been reached.

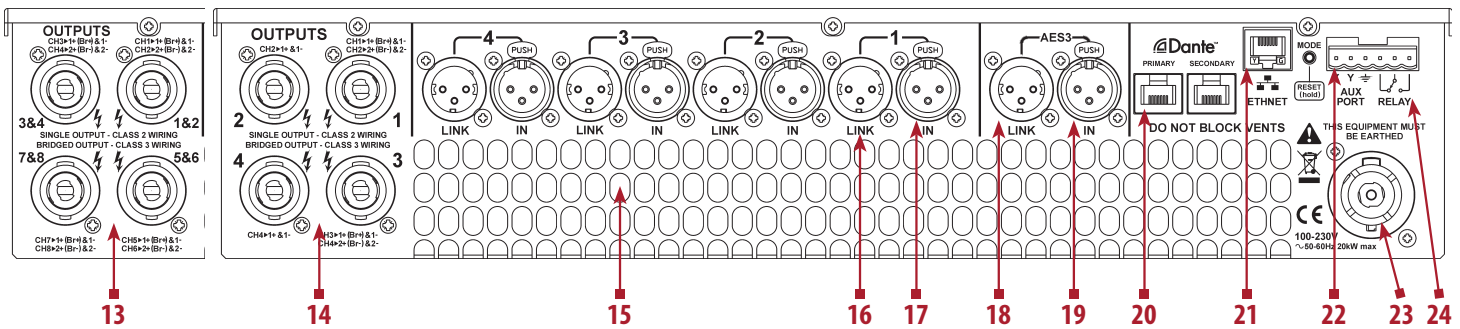

- 13. Loudspeaker Connectors (UXA4810)**– Odd channel numbers are connected to the 1+ and 1- terminals, even channel numbers are connected to the 2+ and 2- terminals. For Bridged mode, use terminals 1+ and 2+. Only use genuine Neutrik™ Speakon™ connectors.
- 14. Loudspeaker Connectors (UXA4406 and UXA4410)**– The numbered connectors carry their corresponding channels on the 1+ and 1- terminals. Connector 1 also carries the output for channel 2 on terminals 2+ and 2-. Similarly, connector 3 also carries the output for channel 4 on terminals 2+ and 2-. For Bridged mode, use terminals 1+ and 2+ of either CH1 or CH3. Only use genuine Neutrik™ Speakon™ connectors.
- 15. Air Exhaust Vents**– These must not be obstructed and there must be a clear path for hot air to exit any rack system. corresponding analog input connectors.
- 16. Analog Audio Link Connectors**– These are directly connected to their corresponding analog input connectors.
- 17. Analog Audio Input Connectors**– All audio connections are fully balanced and wired: pin-1 to chassis (as required by the AES48 standard), pin-2 hot & pin-3 cold.
- 18. AES3 Audio Link Connector**– The Link connector carries a buffered version of the signal on the AES3 input connector. In the event that an amplifier is not powered, AES3 input and Link are directly connected. Do not ‘daisy-chain’ more than 8 amplifiers from a single AES3 source.
- 19. AES3 Digital Audio Input Connector**– The Input is fully balanced, transformer isolated and terminated. It is wired: pin-1 to ground, pin-2 data+ & pin-3 data.
- 20. Dante Audio Ports**– Used to connect to Dante network. Can be configured for switched or redundant operation.
- 21. Ethernet Communications Port**– Used for remote control and monitoring via Resolution Software.
- 22. AUXiliary Port**– The aUXiliary port may be configured for a variety of purposes. See the *AUXA Port* section.
- 23. Mains Power Inlet**– Connection to the mains supply must only be made with a genuine Neutrik™ Powercon™ 32A connector. The amplifier is designed to operate from a nominal mains voltage between 100V and 230V, 50/60Hz without re-configuration.
NOTE: The amplifier must be connected to a suitable mains earth; failure to do so will affect safety, performance and will invalidate the manufacturer’s warranty.
- 24. Relay Output**– This isolated relay output may be used to indicate abnormal conditions to external monitoring apparatus. See the *Fault Relay* section.

Operation

Starting up the unit

When power switch is switched on the unit will go through its start-up cycle, checking all the sub-systems as it does so. Along the way, the screen will inform you of its progress. Once this is complete the display will then show the Home screen indicating input/output configurations.

Navigation

Parameter navigation and adjustment on the UXA Series is very straightforward. There is no concept of drilling down deeper into hidden menus; every parameter is accessible by simply scrolling across a 'map' of parameter pages which can be thought of as placed on a 2-dimensional grid. Horizontally across the width of the grid are the various channels, and vertically up and down the grid are the parameter pages for each section of processing.

To view a parameter, repeatedly press the desired **<INPUT>** or **<OUTPUT>** channel button until the desired channel is reached. Then repeatedly press the up **<▲>** and down **<▼>** buttons to scroll through the processing parameters for the selected input/output.

Two encoders allow you to select and adjust a parameter. Often, several parameters will be shown in various zones on the display. To select a parameter for adjustment, turn the right-most encoder such that the parameter you wish to adjust is highlighted. Then turn the leftmost encoder to adjust the value of that parameter. Turning this encoder clockwise will increase the value of a parameter, or anticlockwise will decrease it. The encoders are velocity-sensitive so turning an encoder rapidly will cause the action to 'accelerate', so the value changes more rapidly.

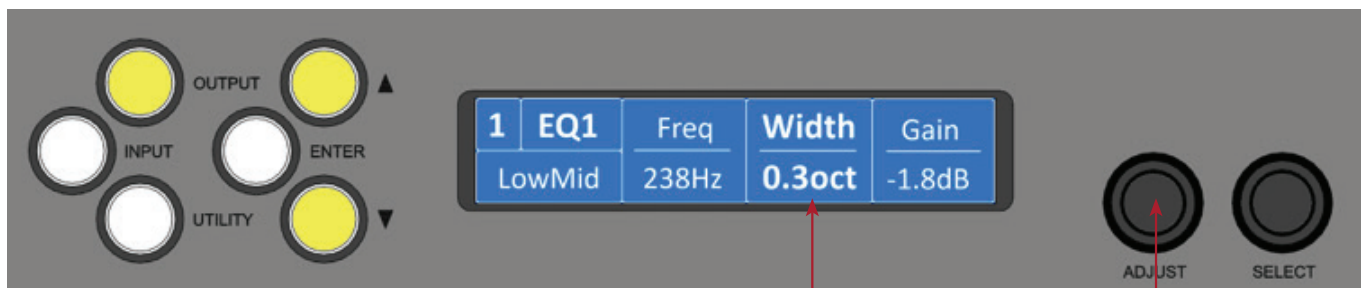

Turn the SELECT encoder to highlight the zone you wish to adjust.

Turn the ADJUST encoder to change its value.

The Home Page

The Home Page presents an overview of the configuration of the device. It indicates the user-define Device Name at the top, and shows the four **Input Channels**. The top line shows the Input DSP channel ('A', 'B' etc), and the name the user has given to this channel. The bottom line shows the physical input number, and a list of the outputs which are routed from the input channel.

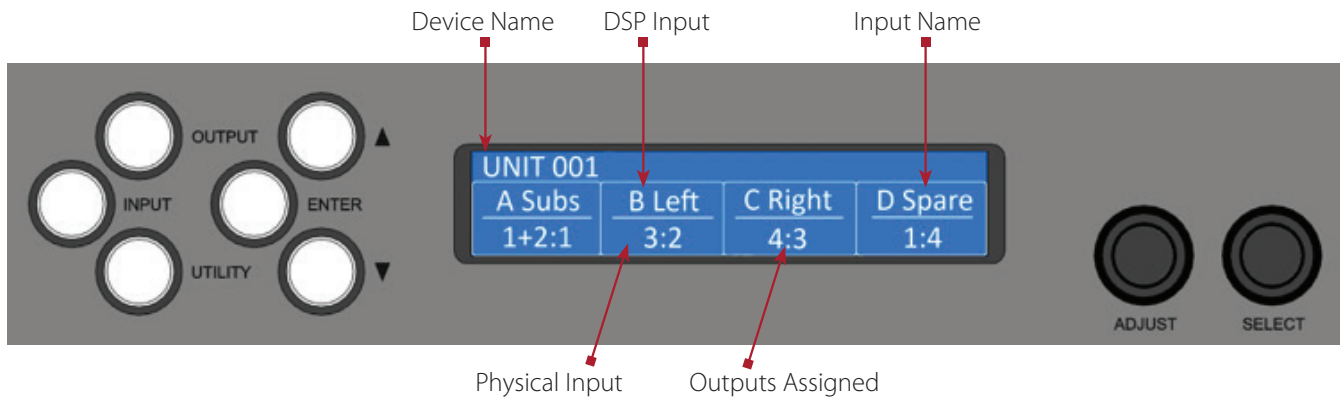

AES3 Inputs

In addition to the usual analog inputs, the Device can also accept AES3 digital inputs. When a DSP input channel is assigned to an AES3 channel, the "AES3" indicator will illuminate.

There is no 'standard' for the relative gains between Analog and AES3 so depending on the levels delivered by the audio source, it may be necessary to adjust the digital input gain trims to normalise them. It is possible to adjust the gain of the AES3 input using the Input Trim AES3 Gain parameter. For example, to achieve 0dBFS = +18dBu, set the AES3 trim to -2dB. To achieve 0dBFS = +24dBu, set the trim to +4dB.

This device will automatically lock onto any sample rate within the range 28kHz and 108kHz.

Dante Inputs

It is possible to select any channel(s) as being sourced from the Dante network. To do this, connect the Dante network connection to the connection on the rear of the Device, and set the relevant Input Type menu Type parameter to “Dante”.

When a Dante channel is routed to an input, the “Dante Audio” indicator above the encoders will illuminate. This indicator will come on even if there are no cables plugged into the networked audio port on the Device.

As for the AES3 inputs, it is possible to set the relative gain between an Analog input and the signals sourced from the Digital Audio Network using the Input Trim Dante gain parameter.

The amplifier will automatically select the correct sample rate from the incoming stream.

For other details on the operation of the Digital Audio Network, please refer to the relevant manufacturer’s documentation.

Automatic Input Selection (Fallover)

It is possible to configure the input selection to be automated. The Input TYPE screen has a Fallover parameter, which defaults to Manual, allowing you to select what Type of input you wish to use. When Fallover AES3>Analog is selected (on an input channel which supports AES3), then the AES3 source will be automatically selected if it has a valid audio stream on it. If the AES3 stream should fail, then Analog is automatically selected instead.

When Fallover Dante>Analog is selected, then the Dante source will be automatically selected if it has a valid audio stream on it. If the Dante stream should fail, then Analog is automatically selected instead.

Similarly, it is possible to select Fallover Dante>AES3 on a channel that supports AES3.

The ‘Auto’ setting allows the highest priority input source that is active to be automatically selected, so the user could just plug a source into any input and it will be automatically selected. The priorities are: Dante first, AES3 second, Analog third.

Note that any automatic selection will take precedence over manual selection, so if you try to manually select Dante when there is no valid Dante stream, then it will revert to the fallover input source.

Gain and Polarity

The gain page of the input channel selected allows users to increase or decrease the amount of signal going into the selected input. Using the “SELECT” encoder to highlight the Gain value allows the value to be changed by the “ADJUST encoder in 0.2dB steps from -40dB to +20dB. This page will also allow users to change the polarity of the selected input from normal to reverse. And to mute the selected channel.

Delay

The delay page which controls the amount of delay associated with the input channel selected and is adjustable from 0 to 998ms. The delay parameter is adjustable in fine steps at low values; the adjustment becomes progressively coarser as the value increases.

High Pass Filter

System high pass filtering is provided for the input signal. Filter type is selectable from 1st order, Butterworth, Bessel, Linkwitz-Riley and Hardman. Filter slopes of up to 4th order or 24dB / octave are provided. Not all filter types are available in all slopes. For example 18dB / octave Linkwitz-Riley filters do not exist.

The Hardman type filter is always described by its order as the filter becomes progressively steeper rather than following a linear slope so a dB/octave description is not accurate.

Parametric Equalization

There are nine stages of equalization available for each input channel, three shelving filters and six parametric filters.

FIR Linear Phase Equalization

The Input High-Shelf Equalizers use Finite Impulse Response (FIR) filtering to produce Linear Phase equalization; that is all frequencies are delayed by the same amount, perfectly preserving the transient response. This can also be important in applications where different amounts of EQ are applied to different parts of a speaker cluster, such as to add 'Throw' EQ boost so that parts of cluster which are throwing further can have HF absorption correction added. If this EQ is not linear phase, then the zones where the speakers combine may suffer frequency response anomalies.

Being a linear phase FIR equalizer, this necessarily introduces some latency delay, which is constant regardless of the settings. However, when the 'Enable' parameter is set to "Off", it is removed from the signal path entirely, so it does not add any latency. In this page you can change the frequency parameter from 2kHz to 20kHz, enable/disable the filter, and change the cut or boost in 0.2dB increments. The filter (and its associated latency) can be completely removed by setting the enable parameter to the "Off" position.

Also see *Bandwidth Units* in Utilities.

Parametric Filters

Parametric filters are defined by frequency, bandwidth and gain. The frequency is adjustable over the range from 10Hz to 25.6kHz. The bandwidth shown as Width on the screen, ranges from 0.10 octaves to 5.2 octaves. Bandwidth can be shown and adjusted as Q or Octaves (Oct). Gain is adjusted in 0.2dB increments.

Also see *Bandwidth Units* in Utilities.

Routing

Routing allows users to route any physical analog or digital signal channel to any DSP input. This is effectively a matrix mixing system where all DSPs can be driven from any one input, or from combinations of inputs **"1+2"**, **"3+4"**, **"1+3"**, **"1+4"**, **"2+3"**, **"2+4"**, **"1+2+3"** or **"1+2+3+4"**. Summed inputs each have appropriate attenuation so that a sum of largely similar programme material remains at the correct calibrated level.

Output

Gain and Polarity

The gain page of the output channel allows users to increase or decrease the relative signal gain for the selected output. The Gain value may be adjusted in 0.2dB steps from -40dB to +20dB. This page will also allow users to change the polarity of the selected output from normal to reverse.

Delay

The delay page controls the amount of delay associated with the output channel selected and is adjustable from 0 to 998ms. The delay parameter is adjustable in fine steps at low values; the adjustment becomes progressively coarser as the value increases.

High and Low pass Filters

High pass and low pass crossover filtering is provided for the output signal. Filter type is selectable from 1st order, Butterworth, Bessel, Linkwitz-Riley, Hardman and LIR Linear Phase. Filter slopes of up to 8th order or 48dB / octave are provided. Not all filter types are available in all slopes. For example 18dB / octave Linkwitz-Riley filters cannot be selected because they do not exist.

The Hardman type filter is always described by its order as the filter becomes progressively steeper rather than following a linear slope so a dB/octave description is not accurate.

Parametric Equalization

There are ten different EQ filters; two shelving filters and eight parametric filters. Parametric filters are defined by frequency, bandwidth and gain. The frequency is controlled over the range from 10Hz to 25.6kHz. The bandwidth, shown as Width on the screen, ranges from 0.10 octaves to 5.2 octaves. Bandwidth can be shown and adjusted as Q or Octaves (Oct). Gain is adjustable in 0.2dB increments.

Limiter

Three parameters are available for adjustment:

Threshold – the continuous RMS voltage which the driver should be able to withstand. This is calibrated at the output of the amplifier. The Limiter can be defeated by setting the Threshold to the maximum "Off" value.

Attack – The time-constant of the speed at which the driver heats up (in seconds).

Release – The time-constant of the speed at which the driver cools down expressed as a multiple of the Attack time.

Please note that whilst the limiters in this product offer protection for amplifier and drivers, they can never protect from all possible scenarios, therefore, EAW is not responsible for any damage which might occur.

Bridge

When an amplifier pair is set to Bridge Mode, it uses two amplifier channels to drive one loudspeaker with greater power. In this mode, only one set of Output controls is active per pair of amplifier channels since both of the amplifiers in the pair are driven with the same signals, as determined by the left-hand (lower numbered) channel of the pair controls.

Bridge Mode is enabled or disabled in the AMP page for a given odd numbered Output. When enabled, the Bridge indicator will be illuminated between the bridged channels.

When Bridged, the partner (even numbered) channel will not show any signal on the limiter meter, and the Mute button will not operate, neither will you be able access any of its parameters for adjustment. The Amplifier protection indicator however will still operate.

Routing

Outputs can be driven from any DSP input.

Driver

The optimal drive level may be adjusted for a given driver impedance using the Load parameter. See *Load Matching*.

The live measured impedance value is also shown on the Driver page. Since the device can only measure this when there is a signal, the impedance is indicated as “?” when there is insufficient signal level to perform a measurement.

Utility Pages

Screen Contrast

The Screen page in the “**UTILITY**” section adjusts the contrast (and optimal viewing angle) of the screen from 0-100% in 1% increments.

Current Ethernet IP Address

This may be viewed in the “**IP Curr**” page of the “**UTILITY**” menu. This value cannot be edited.

IP Mode

The Ethernet IP address may be automatic “**Auto**” or may be a fixed static value “**Static**” as determined by the “IP Mode” page of the “**UTILITY**” menu.

WARNING – Do NOT use Static mode unless your IT system specifically requires it. Auto mode should always be used where possible since in this mode, the Device can always be ‘discovered’ by EAW Resolution software application. When in Static mode, the IP Address will flash on the Home screen.

Also see *Ethernet Configurations*.

IP Static

This allows the Static Ethernet IP address to be adjusted by the rotary encoders on the IP Static page of the “**UTILITY**” menu. This page will only be visible when in Static mode.

Bandwidth Units

This page of the “**UTILITY**” menu allows the Bandwidth of Parametric Equalizers to be viewed and adjusted in either Octaves or ‘Q’.

ECO

This page of the “UTILITY” menu allows the device to save power by going into a low power mode when it is not being used.

Standby is a fast mode which saves some energy, but will wake-up very quickly if an audio input is detected. The associated Standby Time parameter allows the amplifier to automatically go into power-save if no audio signal has been detected for a period of time. This function can be defeated by setting the latter control to Manual. Linea would strongly advise leaving it set to automatic however as there is no negative consequence to doing this since ‘wake-up’ on detecting the presence of an audio input signal is instantaneous.

The Standby Now ‘parameter’ allows the amplifier to be put into standby mode manually when it is not being used.

Sleep is a deep power save mode which saves the most energy, however it will take a small number of seconds for the amplifier to wake-up, and it may only be woken up manually (either from EAW Resolution software application or by switching the device off then on again). The associated Sleep Time parameter allows the amplifier to automatically go into Sleep mode if no audio signal has been detected for a period of time. This function can be defeated by setting the latter control to Manual.

External Breaker Protection (EBP)

The Power (“PWR”) utility page provides access to the External Breaker Protection (EBP) feature, which allows the output power to be limited in order to prevent the nuisance tripping of mains circuit breakers or fuses when the amplifier needs to be operated on a mains supply with restricted capacity. Set the EBP value to that of the circuit breaker or fuse to which the amplifier is connected.

Ethernet**Ethernet configurations**

IP addressing in the Device can be completely automatic; No setup is required.

DHCP

There are two primary IP address ranges – one used when there is a DHCP server, and another (‘Link Local’) where there is no DHCP server (so the Device and the Computer will instead use ‘Auto IP’ to allocate themselves an IP address). Both the device and the computer must be in the same IP address range. In a local network environment such as an office where there is a DHCP server, both the computer and the Device will be in the DHCP IP address range, and so will connect immediately.

AUTO-IP

The device will initially search for a DHCP server when first switched on (during which time its Online Indicator will be flashing). As it can take up to one minute to establish that there is no DHCP server available, this is the time it may take before Auto IP is entered.

Please be aware that it can also take some time from a computer being switched on in an isolated network (without a DHCP server), or unplugged from a network with DHCP to time out of DHCP searching, so it will not connect immediately to amplifiers that are already using Auto IP. The time it takes before it decides to revert to

Auto IP depends on the operating system but it can take several minutes to acquire an Auto IP address.

Static-IP

If the device or the computer has a static IP address set, EAW Resolution software may not be able to 'see' the device if it is in a different IP Address range (i.e. in a different subnet).

AUX Port

The AUX has two inputs, X & Y. These allow simple contact closure devices (relays or switches) or external logic signals to change the state of the amplifier as described below. Connecting an AUX input to ground (the earth symbol) will trigger it; there is no requirement for an external voltage. However, the ports can also be triggered directly by a logic signal as long as the logic 'low' goes below +0.5V. Do not connect systems if their logic 'high' voltage exceeds +24V.

The AUX port is configured with the following functionality.

- **Mute+Sleep** (State) – The device may be muted by grounding AUX X or placed in Sleep by grounding AUX Y

This table shows the action taken for various AUX connection patterns in the various AUX port modes:

AUX X	AUX Y	Mute+Sleep (State)
Open	Open	No Change
Gnd	Open	Mute
Open	Gnd	Sleep
Gnd	Gnd	Sleep

Secure Mode

When activated, this will disable all the front panel controls so they cannot affect the signal path, making the unit secure against tampering. When in secure mode, the indicators still operate normally. To activate secure mode, press and hold the utility button for 5 seconds. To deactivate, press and hold the utility button for 5 seconds. When in secure mode, this will be shown on the display. Note that the Ethernet communications port is still active in secure mode.

Protection Systems

Comprehensive protection features preserve the longevity of the loudspeaker and amplifier by continuously monitoring several critical parameters, and reducing the gain, or muting the amplifier either temporarily or permanently depending on the nature and seriousness of the fault or misuse. The amplifier will recover and restart if at all possible, but may remain in shut down if a serious fault persists.

Limiters deal with routine over-driving of the amplifier, making sure that the driver(s) are not pushed too hard. The limiter indicators will warn you when the driver is being driven into limit.

Minor faults are dealt with by 'dimming' the amplifier, reducing the level to a sufficient degree and for a sufficient time that the amplifier is able to recover gracefully without any user interaction. When the fault condition has passed, the amplifier will recover automatically.

When the protection systems are reducing the level, this is indicated by illuminating the left-hand Amplifier channel protection indicator. This will also illuminate when the output voltage is 'clipping'.

This indicator will remain permanently illuminated if the channel has been muted by the protection systems. The Mute button will also flash. This will usually also be indicated by a warning message on the display.

Some types of protection affect all output channels, so you may see the Amplifier indicator illuminated, and the Mute button flash, on every channel.

Summary of Protection Indication

The reasons for the protection indicators illuminating are summarised as follows:

Amplifier Indicator	Driver Indicator	Notes
	Limiter engaged	
Amplifier clipping		
Amplifier clip limiting		
Amplifier Current limiting		
Amplifier VHF limiting		
PSU Current limiting		Will show on all output channels
PSU Power limiting		Will show on all output channels
Thermal limiting		Will show on all output channels

Incident Reporting

Fault Relay

Three connections are available via the Phoenix connector for this relay. The schematic representation printed on the rear panel shows the 'idle' state of the relay (when the amplifier is not switched on). When the amplifier is switched on, the relay will normally energise. When a Fault incident occurs, the relay will be de-energised. This will allow either a Fault Incident or a loss of power to be seen as a 'Fault'.



EAW

Eastern Acoustic Works

One Main Street | Whitinsville, MA 01588 | USA

tel 800 992 5013 / +1 508 234 6158

www.eaw.com

©2019 Eastern Acoustic Works

All rights reserved. Products are not drawn to scale.

All terms, conditions, and specifications subject to change without notice.