



APPLICATION

- For medium-sized theaters
- Bi-amplified 3-way screen channel loudspeaker

PRODUCT INFORMATION

The CB523MX full-range screen channel loudspeaker system offers medium-sized theaters a cost-effective entry to the future of cinema audio – 3-way loudspeaker design. Its passive mid/high design lets it replace existing biamped two-way systems without requiring new electronic crossovers or amplifiers. (Electronic crossovers may require adjustment.)

Three-way design dramatically advances cinema audio quality by improving the naturalness and intelligibility of dialog, eliminating distortion from excessive driver excursion and extending pattern control into the lower octaves.

The two component system includes a BV253C dual 15-in low frequency enclosure and an HK523MX mid/high section.

The low frequency enclosure uses optimally tuned enclosure venting to increase LF response while limiting driver excursion. This method produces less distortion and minimizes driver strain while extending LF response to the lowest octaves. The enclosure's shallow dimension allows convenient placement behind the screen.

The HK523MX MF/HF section features a horn-loaded 10-in cone and a high power 1.4-in exit compression driver loaded with a 90° x 45° coverage pattern constant directivity horn.

The adjustable steel bracket attaching the mid/high section to the LF enclosure can be positioned at one of three mounting points for optimum front/rear placement. The bracket allows the mid/high section to be aimed independently of the LF section in both the horizontal and vertical planes and can be locked once it is positioned.

The HK523MX's mid and high frequency sections are integrated via a complex passive crossover/filter network. EAW's computer-designed passive filter networks are tightly aligned to the loudspeakers they control and go beyond merely dividing the signal, performing critical equalization functions.

Two-terminal barrier strip input connectors that accommodate bare wire, tinned leads or spade lugs are included for both the LF and mid/high sections. The input panels are located on the sides and top of the enclosures for convenient access in cramped installation areas.

All external components feature a non-reflective, textured black finish to eliminate the reflection of light through perforated cinema screens.

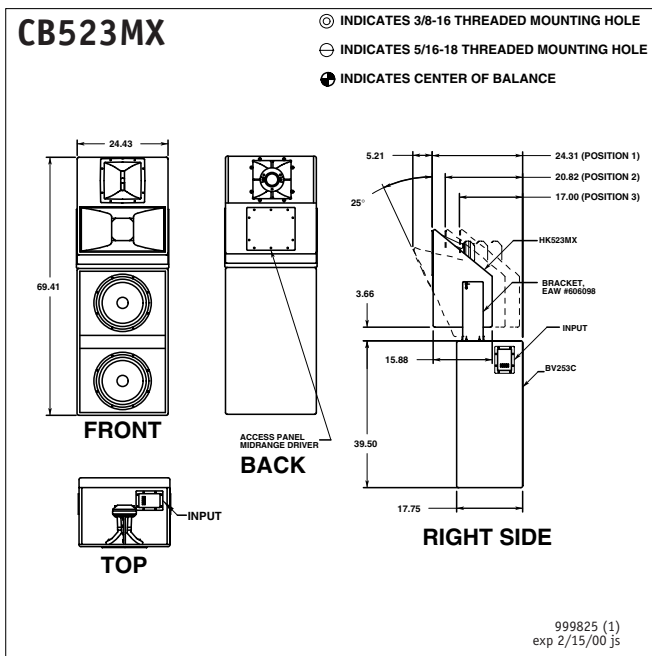

COMPONENTS & CONSTRUCTION

The CB523MX is a biamplified (passive mid/high) three-way, high-output, full range loudspeaker system intended for use in behind-screen cinema applications. The two component system includes a BV253C dual 15-in low frequency enclosure and an HK523MX mid/high system.

The system requires the use of an external active electronic crossover between the LF and mid/high sections with a maximum recommended crossover point of 300 Hz. The mid/high component includes an internal passive crossover/filter network with the crossover set at 1.8 kHz integrated via a complex passive crossover/filter network. EAW's computer-designed passive filter networks are tightly aligned to the loudspeakers they control and go beyond merely dividing the signal, performing critical equalization functions.

The BV253C low frequency component features dual 15-in woofers mounted in a vented enclosure for excellent bass extension and high output level capability.

The HK523MX mid/high component features a horn-loaded 10-in midrange driver and a 1.4-in exit compression driver mounted to a medium format 90° x 45° constant directivity horn.

Input connectors for both the LF and mid/high components are 2-terminal barrier strips that accommodate bare wire, tinned leads or spade lugs. A pre-installed "jumper cable" continues the signal chain to the HF section.

The LF cabinet is constructed of 3/4-in Medium Density Fiberboard (MDF). The HK523MX mid/high section is constructed of 3/4-in MDF with the exception of the mid frequency flare which is void-free, 18-ply-to-the-inch, Baltic birch plywood backed with high density polyurethane foam. Both sections are coated with a non-reflective, textured black finish and the HF horn is constructed of flat black structural foam plastic.

DESCRIPTIVE DATA

LF Subsystem & Loading	2x 15-in vented
MF Subsystem & Loading	1x 10-in horn loaded
HF Subsystem & Loading	1x 1.4-in exit compression driver on CD horn
Number of Audio Bands	3-way
Powering Mode	Biamp
Recommended Crossover	EAW CX300-CB523MX
Cabinet Type (shape)	Rectangular
Enclosure Materials	LF-3/4-in MDF; 15mm Birch plywood baffle — MF/HF-MDF
Finish	Textured Black
Connectors	2x 2-Terminal Barrier Strip

NOMINAL DATA

Frequency Response (1 Watt @ 1m)		
±3 dB	42 Hz - 19 kHz	
Axial Sensitivity (dB SPL, 1 Watt @ 1m)		
LF	101	
Passive MF/HF	105	
Impedance (Ohms)		
LF	4	
Passive MF/HF	8	
Power Handling (Watts)		
LF	1000	
Passive MF/HF	350	
Calculated Maximum Output (dB SPL @ 1m)		
LF Peak	137.0	
Passive MF/HF Peak	136.6	
LF Long Term	131.0	
Passive MF/HF Long term	130.6	
Nominal Coverage Angle/-6 dB points (degrees)		
Horizontal	90	
Vertical	45	
Dimensions & Weights		
	Inches	Centimeters
Height	69.41	1763
Width	24.80	63.0
Depth	17.75	45.1
Weights		
	Pounds	Kilograms
Net Weight	215	97.5
Shipping Weight	230	104.3

