

8. Ground Stacking JFL210 Loudspeakers on the FB121 Fly Bar:

A limit of four (4) JFL210 Loudspeakers may be stacked and locked on an FB121 Fly Bar. Only one (1) person is required to stack the first three (3) JFL210 Loudspeakers on the Fly Bar. When a fourth JFL210 is to be stacked two (2) persons are required.

a. Position a JFL210 Loudspeaker on the Fly Bar so its two (2) side Rigging Tubes are aligned above the fixed Latches in the Fly Bar.

b. Remove the two (2) side Quick Release Pins from the Fly Bar. They may be inserted in the Latch through holes for storage.

c. Remove the two (2) side Quick Release Pins from the sides of the JFL210 Loudspeaker; the Latches will drop and rest atop the Fly Bar's fixed Latches.

d. Align the holes in the JFL210's Latches and the holes immediately above the Fly Bar's Latches. Lock the Loudspeaker in position by fully inserting the Quick Release Pins removed in the preceding step.

e. Stack additional JFL210 Loudspeakers as required. This procedure is similar to that outlined in Sections 3b through 3d in these Instructions. Note however that JFL210 only has two (2) Rigging Tubes and Latches.

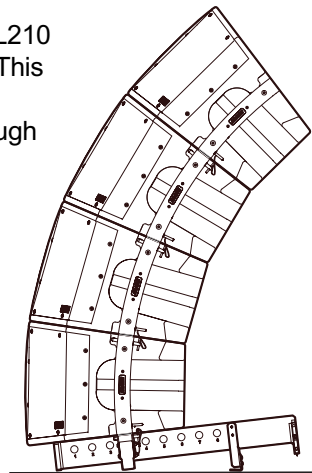
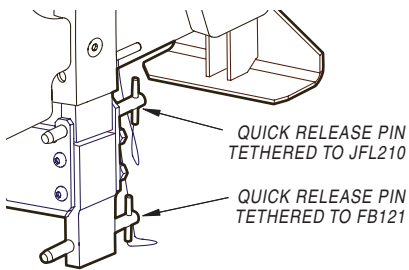

9. Ground Stacking a JFL210 / JFL118 Loudspeaker Array:

The FB121 Fly Bar is not required for this application, as the JFL118 is used as the ground stack base.

A limit of four (4) JFL210 loudspeakers may be stacked on up to two (2) JFL118 Loudspeakers. Two (2) persons are required to lift and stack the Loudspeakers in a mixed Array. Loudspeaker stacking and locking procedures outlined in Sections 3a thru 3d in these Instructions should be followed.

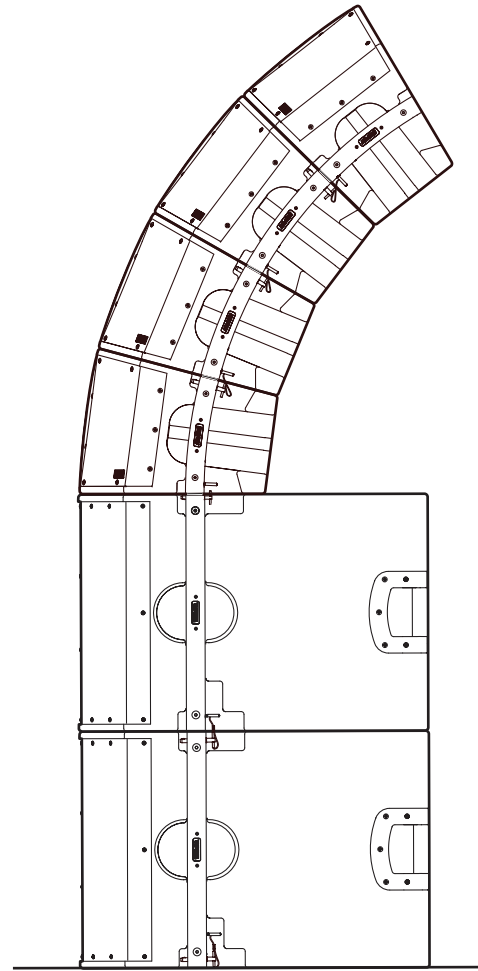

EAW Instructions/Installation FB121 Rigging & Ground Stack

Warning: Suspending loudspeakers should be done with extreme caution and by a certified professional who is qualified to determine the requirements for and to implement overhead rigging. Failure to follow proper precautions may result in damage to the equipment, injury, or death.

INTRODUCTION:

JFL210 and JFL118 Loudspeakers are intended to be suspended below a hoisted FB121 Fly Bar. The Fly Bar is also used as a Base when stacking JFL210 Loudspeakers on the ground. The Fly Bar is not used when ground stacking the JFL118 Loudspeaker. The JFL118 is instead placed directly on the ground.

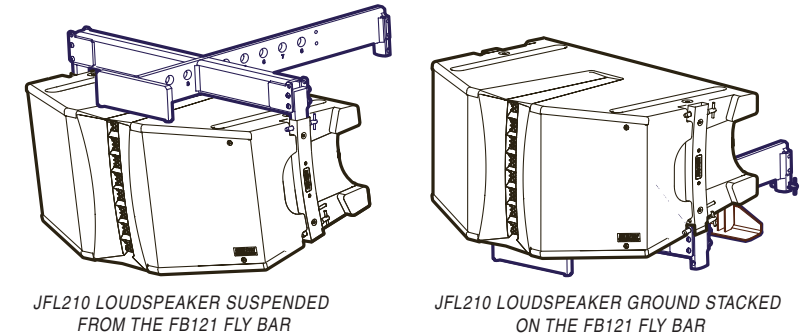

These Instructions will first explain how to suspend Loudspeakers from the FB121 Fly Bar, then explain how to use the Fly Bar as a Base on which to stack a JFL210 Array. Note that a Foot Assembly must be attached to the Fly Bar before using the FB121 as a ground stack Base. It comes in a separate, included Kit. Installation is explained in the second half of these Instructions.

SUSPENDING JFL210 & JFL118 LOUDSPEAKERS:

WARNING: When the FB121 Fly Bar is used for suspension its WORKING LOAD LIMIT (WLL), Total Vertical Pull, is limited to six (6) any combination JFL210 or JFL118 Loudspeakers. The WLL Design Factor is 10:1.

WEIGHTS:

FB121 Fly Bar: 27 lb / 13 kg; JFL210 Loudspeaker: 52 lb / 24 kg; JFL118 Loudspeaker: 98 lb / 44.5 kg

1. Positioning a Fly Bar Shackle:

The Fly Bar is suspended by a user-supplied Shackle. Its position on the Fly Bar's numbered Center Bar is determined by the required Array Configuration and aiming angle. Refer to the JFL software Wizard for appropriate Shackle positioning.



2. Attaching the Shackle and Hoist Cable:

A user-supplied Screw Pin Anchor Shackle or Safety Bolt Anchor Shackle is used to affix a Hoist Motor and/or Cable to the Fly Bar. Allowable Shackle sizes are:

Minimum 0.75 T, 9 mm / 0.31 in
Maximum 3.25 T, 16 mm / 0.63 in

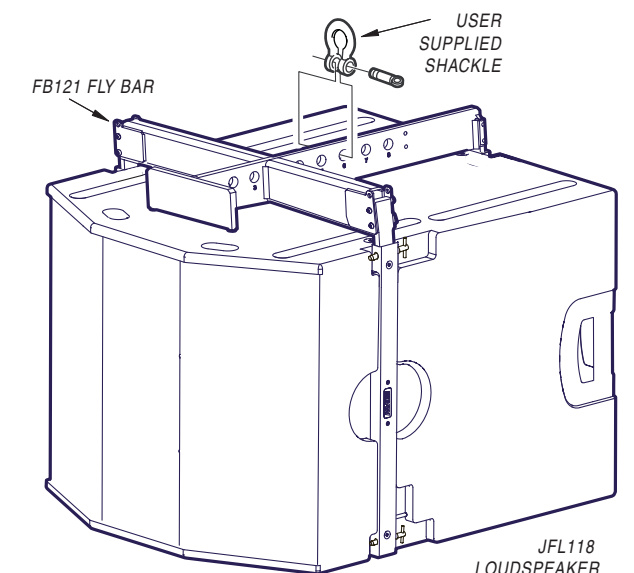

If you have questions about these FB121 Fly Bar Rigging & Ground Stack Installation Instructions please contact the EAW Application Support Group:

Tel 800-992-5013 (USA only)
Tel 508-234-6158
Fax 508-234-8251
E-mail asg@eaw.com

The Laws of Physics | The Art of Listening



One Main Street, Whitinsville, MA 01588 tel: 800 992 5013 / 508 234 6158 fax: 508 234 8251 web: www.eaw.com

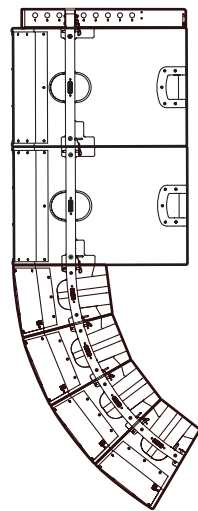

Combinations of JFL210 and JFL118 Loudspeakers may be suspended in the same array. When doing so JFL118s are always suspended above JFL210s. JFL118 are thus attached to the Fly Bar first.

Remember, only six (6) any combination JFL210 and/or JFL118 Loudspeakers may be attached to a suspended FB121 Fly Bar.

3. Suspending JFL118 Arrays:

Two (2) persons are required to lift, stack, and ready JFL118 Loudspeakers for suspension from the FB121 Fly Bar.

- Place a JFL118 Loudspeaker on the floor or similar stable surface under the desired rigging point.
- Stack additional JFL118s (if desired), keying the the stack pads on the enclosure bottom(s) into recesses in the top of adjacent Loudspeaker(s).
- Each JFL118 Loudspeaker has Latches stored in the bottom of three (3) Rigging Tubes. These Latches are held in their stored position by Quick Release Pins. Remove the three (3) Pins; the Latches will release and slide into the three Tubes of the Loudspeaker below them. Align the holes in the Tubes to those in the Latches and lock them together by fully inserting the Quick Release Pins.

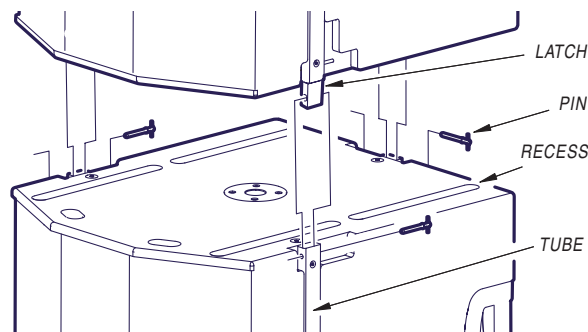

- Remove the FB121 Fly Bar's Quick Release Pins and insert its three fixed Latches into the top JFL118's Rigging Tubes. Align the holes in the Tubes to those in the Latches and lock them together by fully inserting the Quick Release Pins.
- Hoist the array to the desired trim height or to the working height needed for the next applicable procedure.

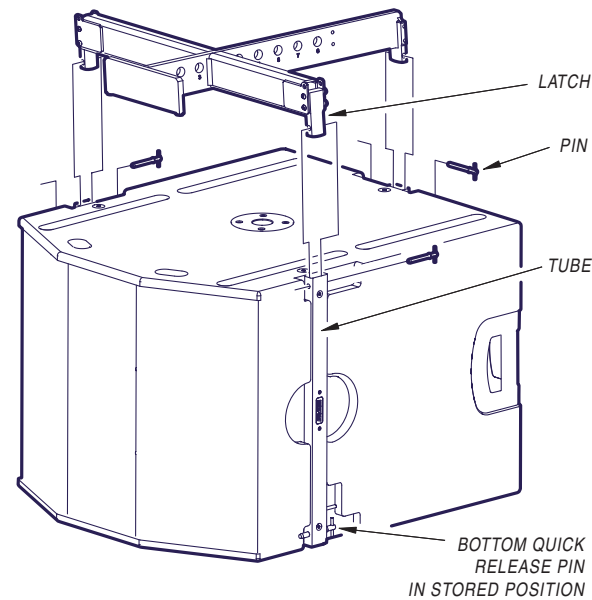

4. Attaching JFL210 Loudspeakers to a Suspended JFL118 Loudspeaker:

Two (2) persons are required to lift and attach a JFL210 Loudspeaker to a suspended JFL118 Loudspeaker.

- The two (2) side Latches on the bottom suspended JFL118 Loudspeaker must be lowered from their stored position. Do this by removing the two (2) bottom Quick Release Pins; the Latches will drop to their ready position. The bottom rear Latch should remain pinned in its stored position.
- Lift and position the JFL210 Loudspeaker so its Rigging Tubes capture the two (2) side Latches of the JFL118 Loudspeaker. Align the holes in the Tubes to those in the Latches and lock them together by fully inserting the Quick Release Pins.
- Repeat this step for any additional JFL210 Loudspeakers to be added to the Array.
- Hoist the array to the desired trim height.

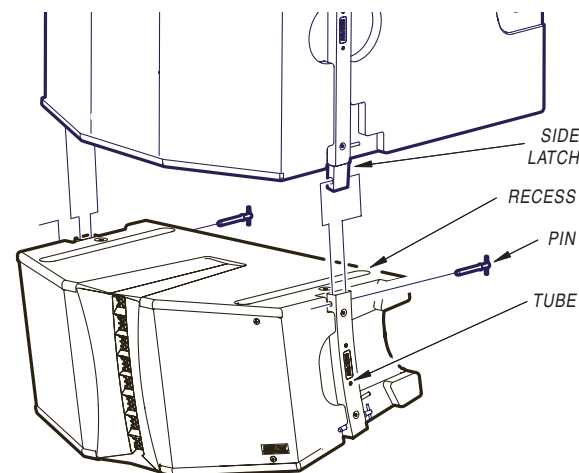

5. Attaching JFL210 Loudspeakers to the FB121 Fly Bar:

Only one (1) person is required to suspend the first three (3) JFL210 Loudspeakers from the FB121 Fly Bar. When additional JFL210 Loudspeakers are to be suspended two (2) persons are required.

- Attach a lifting apparatus to the FB121 at the desired rigging point and hoist the Fly Bar above head height.
- Stack and lock together up to three (3) JFL210 Loudspeakers on the floor or similar stable surface under the Fly Bar. This procedure is similar to that outlined in Sections 3b thru 3d in these Instructions. Note however that JFL210 only has two (2) Rigging Tubes and Latches.
- Lower and position the FB121. Remove the Fly Bar's two (2) side Quick Release Pins and insert its two (2) fixed Latches into the Rigging Tubes of the top JFL210 Loudspeaker. Align the holes in the Tubes to those in the Latches and lock them together by fully inserting the Quick Release Pins.
- Hoist the array to the desired trim height.

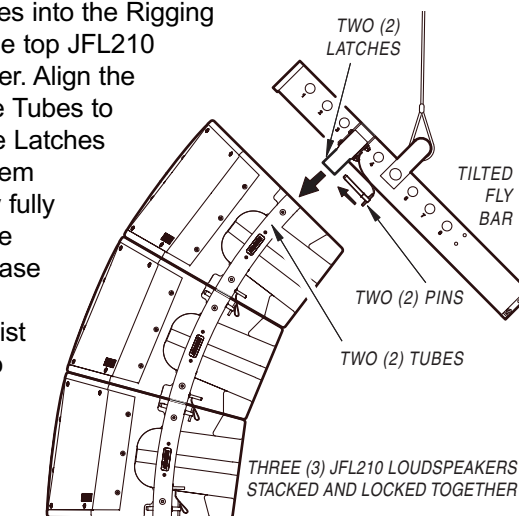

If a fourth, fifth and/or sixth JFL210 Loudspeaker is added, they must be individually lifted and locked to the bottom of the Array by two (2) persons. This procedure is similar to that outlined in Sections 4a thru 4c in these Instructions.

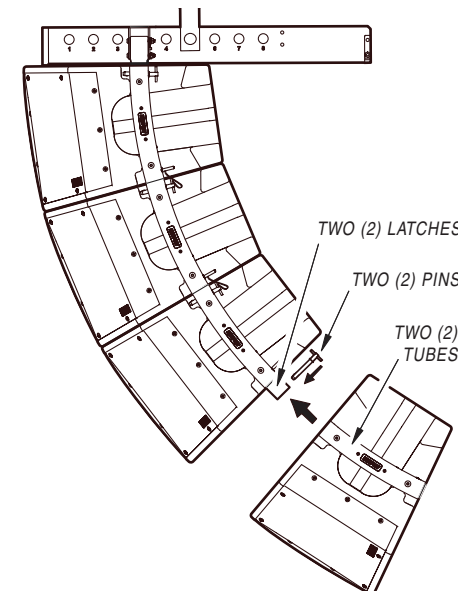

Ground Stacking:

6. The FB121 Ground Stack Foot Kit:

The FB121 Fly Bar requires the use of a supplied Ground Stack Foot Kit to ground stack JFL210 Loudspeakers. This Kit is made up of the following parts:

Item	Qty	Name
A	1	Assembly Bracket Foot FB121
B	2	Screw 6M x 30mm Lg
C	2	Lock Washer 6M

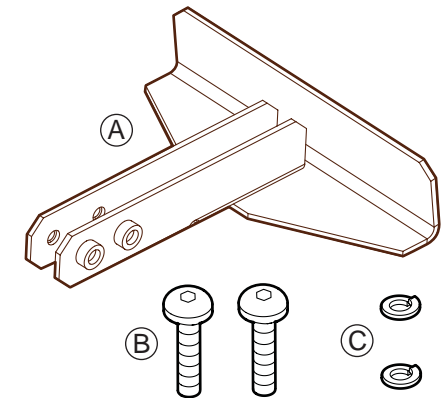

7. Attaching the Ground Stack Foot to the FB121 Fly Bar:

The Ground Stack Foot is mounted to the underside of the FB121 Fly Bar. The Fly Bar is correctly oriented when the hole numbers are right side up and the Fly Bar's fixed Latches point down. The Latches serve as additional feet in a ground stack application.

- With the edge of the Foot facing front, fit the two (2) arms of the Foot on each side of the Fly Bar.
- Align the two (2) holes in the Foot to the holes in the Fly Bar.
- Insert both Screws with their Lock Washers through the holes in the Foot and Fly Bar, then thread the Screws into the internal Nuts on the second arm of the Foot.
- Tighten the two (2) Screws.

