

EAW[®]

EASTERN ACOUSTIC WORKS



 **AC6**
User Manual

AC6 User Manual

IMPORTANT SAFETY INSTRUCTIONS - READ THIS FIRST

Read and heed all warnings and safety instructions in this manual before using this product. Failure to follow these precautions may result in damage, injury, or death.

- 1) Read these instructions.
- 2) Keep these instructions.
- 3) Heed all warnings.
- 4) Follow all instructions.
- 5) Do not use this apparatus near water.
- 6) Clean only with a dry cloth.
- 7) Do not block any amplifier ventilation openings. Install in accordance with the manufacturer's instructions.
- 8) Do not install near any heat sources such as radiators, heat registers, stoves, or other apparatus that produce heat.
- 9) Do not defeat the safety purpose of the polarized or grounding-type plug. A polarized plug has two blades with one wider than the other. A grounding type plug has two blades and a third grounding prong. The wide blade or the third prong is provided for your safety. If the provided plug does not fit into your outlet, consult an electrician for replacement of the obsolete outlet.
- 10) Protect the power cord from being walked on or pinched particularly at plugs, convenience receptacles, and the point where they exit from the apparatus.
- 11) Only use attachments/accessories specified by the manufacturer.
- 12) Use only with the Caster Pallets and flybars specified by the manufacturer, or sold with the apparatus. When a Caster Pallet is used, use caution when moving the apparatus

combination to avoid injury from tip-over.

13) Unplug this apparatus during lightning storms or when unused for long periods of time.

14) Refer all servicing to qualified service personnel. Servicing is required when the apparatus has been damaged in any way, such as power-supply cord or plug is damaged, liquid has been spilled or objects have fallen into the apparatus, does not operate normally, or has been dropped.

CAUTION: Danger of explosion if lithium battery is incorrectly replaced. Do not attempt to replace the battery yourself.

CONSIGNES DE SÉCURITÉ - À LIRE EN PREMIER

Lisez et respectez toutes les consignes de sécurité et les mises en garde fournies dans le manuel des enceintes EAW avant d'utiliser ce produit. Le non-respect de ces consignes et mises en garde peut entraîner des dommages aux équipements et des accidents aux personnes pouvant être fatals.

ATTENTION: L'enceinte est fournie avec un cordon secteur. Selon la tension du modèle commandé, ce câble est fourni avec la fiche la plus communément utilisée avec cette tension. Si la fiche n'est pas compatible avec les prises secteur de votre région, faites appel à un électricien agréé pour modifier le cordon secteur en fonction du format local. Vérifiez que la fiche secteur dispose d'une mise à la terre. Le non-respect de la mise à la terre peut entraîner des dommages aux équipements et des accidents aux personnes pouvant être fatals.

ATTENTION: Danger d'explosion si la batterie au lithium n'est pas remplacé. N'essayez pas de remplacer la batterie vous-même.

AC6 User Manual

PRECAUZIONI DI SICUREZZA - DA LEGGERE PER PRIMO

Norme di Sicurezza

Prima di procedere con l'utilizzo del prodotto, leggere e rispettare ogni avvertenza e norma di sicurezza riportata nel "Manuale EAW Loudspeaker". Il mancato rispetto di ogni precauzione può causare danni all'apparecchiatura, nonché infortuni alle persone o la morte.

ATTENZIONE: Il diffusore è completo di cavo d'alimentazione ac fornito in dotazione. In base la voltaggio del modello di diffusore acquistato, il cavo è configurato con il connettore ac più adeguato. Nel caso in cui il connettore non sia compatibile con le prese di corrente adottate nell'area d'impiego, rivolgersi ad un elettricista qualificato per ri-configurare il cavo con il connettore più appropriato. Assicurarsi che la presa di corrente sia adeguatamente collegata a terra. Il mancato rispetto di tali norme può causare danni all'apparecchiatura, nonché infortuni alle persone o la morte.

ATTENZIONE: Pericolo di esplosione se la batteria al litio non è sostituita correttamente. Non tentare di sostituire la batteria da soli.

PRECAUCIONES DE SEGURIDAD - LEA ESTO PRIMERO

Instrucciones de Seguridad

Lea y observe todos los avisos e instrucciones de seguridad que aparecen en el "Manual de altavoces EAW" adjunto antes de usar este aparato. El no observar esta precaución puede dar lugar a averías en el aparato, daños en las personas o incluso la muerte.

PRECAUCION: El altavoz viene de fábrica con un cable de corriente. Dependiendo del voltaje que use el modelo solicitado, este

cable estará configurado con el enchufe más habitual para ese tipo de corriente. Si ese enchufe no es compatible con su salida de corriente, contacte con un electricista profesional para que cambie el enchufe del cable por el tipo adecuado. Asegúrese de que la salida de corriente tenga una conexión a tierra adecuada. El no observar esta advertencia puede dar lugar a averías en el aparato, daños en las personas o incluso la muerte.

PRECAUCIÓN: Peligro de explosión si la batería de litio se sustituye de forma incorrecta. No intente cambiar la batería usted mismo.

SICHERHEITSHINWEISE - LESEN SIE DIESEN ABSCHNITT ZUERST

Sicherheitsanweisungen

Lesen und beachten Sie alle Warnungen und Sicherheitsanweisungen der mitgelieferten "EAW Lautsprecher Bedienungsanleitung" vor der Benutzung des Produkts. Nichtbeachtung dieser Hinweise können möglicherweise zu Schäden am Equipment oder zu Verletzungen bzw. zum Tod von Personen führen.

WARNUNG: Der Lautsprecher wird mit einem Netzkabel geliefert. Abhängig von der jeweiligen Netzspannung wird das Kabel mit dem für die jeweilige Netzspannung gängigsten Netzstecker ausgeliefert. Sollte der Netzstecker nicht in Ihre Netzsteckdose passen, dann lassen Sie von einem zugelassenen Elektrobetrieb einen passenden Netzstecker montieren. Stellen Sie sicher, dass der Schutzkontakt der Netzsteckdose einen guten Kontakt zur Erde hat. Nichtbeachtung dieser Hinweise können möglicherweise zu Schäden am Equipment oder zu Verletzungen bzw. zum Tod von Personen führen.

ACHTUNG: Explosionsgefahr bei Lithium-Batterie falsch eingesetzt wird. Versuchen Sie nicht, den Akku selbst zu ersetzen.

AC6 User Manual

CAUTION: Changes or modifications not expressly approved by EAW® North America INC could void the user's authority to operate the equipment.



Correct Disposal of this Product

This symbol indicates that this product should not be disposed of with your household waste, according to the WEEE Directive (2002/96/EC) and your national law. This product should be handed over to an authorized collection site for recycling waste electrical and electronic equipment (WEEE). Improper handling of this type of waste could have a possible negative impact on the environment and human health due to potentially hazardous substances that are generally associated with WEEE.

At the same time, your cooperation in the correct disposal of this product will contribute to the effective usage of natural resources. For more information about where you can drop off your waste equipment for recycling, please contact your local city office, waste authority, or your household waste disposal service.

AC6™ System Overview

Adaptive Systems™ are one of the most technologically advanced loudspeakers ever created, including the latest advances in transducer, DSP, mechanical, amplification, and software technology. Through the close integration of these disciplines, the user is free to simply define the coverage, consistency and sound pressure level (SPL) required of the system. With a minimal amount of user-provided information, the AC6 system will use Adaptive Performance to provide optimal sound reinforcement for that specific requirement.

The AC6 system workflow offers a range of entry points and allows the user to assess options for deploying the system. New users may wish to create a model of the venue and ask the Anna system to recommend array configurations based on available inventory. Experienced users may design their own arrays as models and ask the AC6 system to adapt performance to the venue. Masterful users may simply deploy arrays and then ask the system to adapt performance.

On-site, users can readily and quickly manipulate system performance using digital signal processing (DSP) only.

Features and Benefits

The feature set designed into the AC6 offers users a range of advantages in system application and maintenance.

Internal Processing & Amplification

As is true of all professional loudspeaker systems, the performance of the AC6 depends on amplifiers delivering an adequate supply of clean power. To maximize performance, each module includes powerful, built-in, high-efficiency amplifiers that are exactly matched to their transducers. AC6 modules include 36 independent channels of amplification and DSP in order to provide independent control of each transducer. Even though extremely lightweight compared to other products in the same output category, these amplifiers are designed to meet and exceed the exceptionally high output requirements of professional applications.

AC6 User Manual

Infrared (IR) Transceivers

Each time a user powers on an AC6 array, the modules immediately use the IR transceivers on the top and bottom of the cabinet to announce themselves to their neighbors and recognize the announcements of their neighbors. AC6 recognizes each individual and the array as a whole and presents that to Resolution software. Identifying specific modules is not necessary. All that is needed is identifying where each array is located within the venue (left, right, etc.). The AC6 will determine which modules are within each array and how that array is configured.

LEDs

The top of each acoustic module houses a bright white LED that is used for identifying AC6 arrays. It is triggered when the Identify function in Resolution software is activated. In addition, a Fault or Limiter Activation mode can be selected in Resolution and the LED will illuminate when one of these two conditions is met.

***NOTE:** The bottom acoustic module is inverted. The resulting LED arrangement can be used to confirm orientation of the loudspeaker.*

Using the Loudspeaker

Users will need to perform the following general tasks to properly put the AC6 into use. This manual includes details for each task.

1. Design the system using the Resolution™ 2
2. Design & Control Software (see the [program Help File for further information about using Resolution](#)).
3. Design and install suspension points to support the array(s)/rigging in intended locations and aimed in the desired

directions. If ground-stacked, provide a level surface capable of supporting the total weight of the array(s).

4. Connect an audio signal to the loudspeakers in the array or to a Dante™ source.
5. Connect the loudspeakers to a power source.
6. Connect a control computer with Resolution software to the AC6 network.
7. Set-up and adjust overall system gain and signal processing, as needed to maximize the array's performance for the application.
8. Provide training to operate the loudspeakers within their limits.
9. Provide regular inspection and maintenance to maintain the integrity of the installation and the performance of the loudspeakers.

Array Design

See [Resolution Help File](#) for assistance in properly designing AC6 arrays.

Software

EAW Resolution 2 software is designed to control ADAPTive systems. For advanced functions like in-venue optimization, supplemental software such as Rational Acoustics® Smaart™ may be desired, but this is not required for basic system operation.

Always ensure that your EAW Resolution software and AC6 firmware are up-to-date.

For a complete list of recommended system requirements, please refer to the [Resolution 2 help file](#).

AC6 User Manual

AC6 Walkaround (Front)

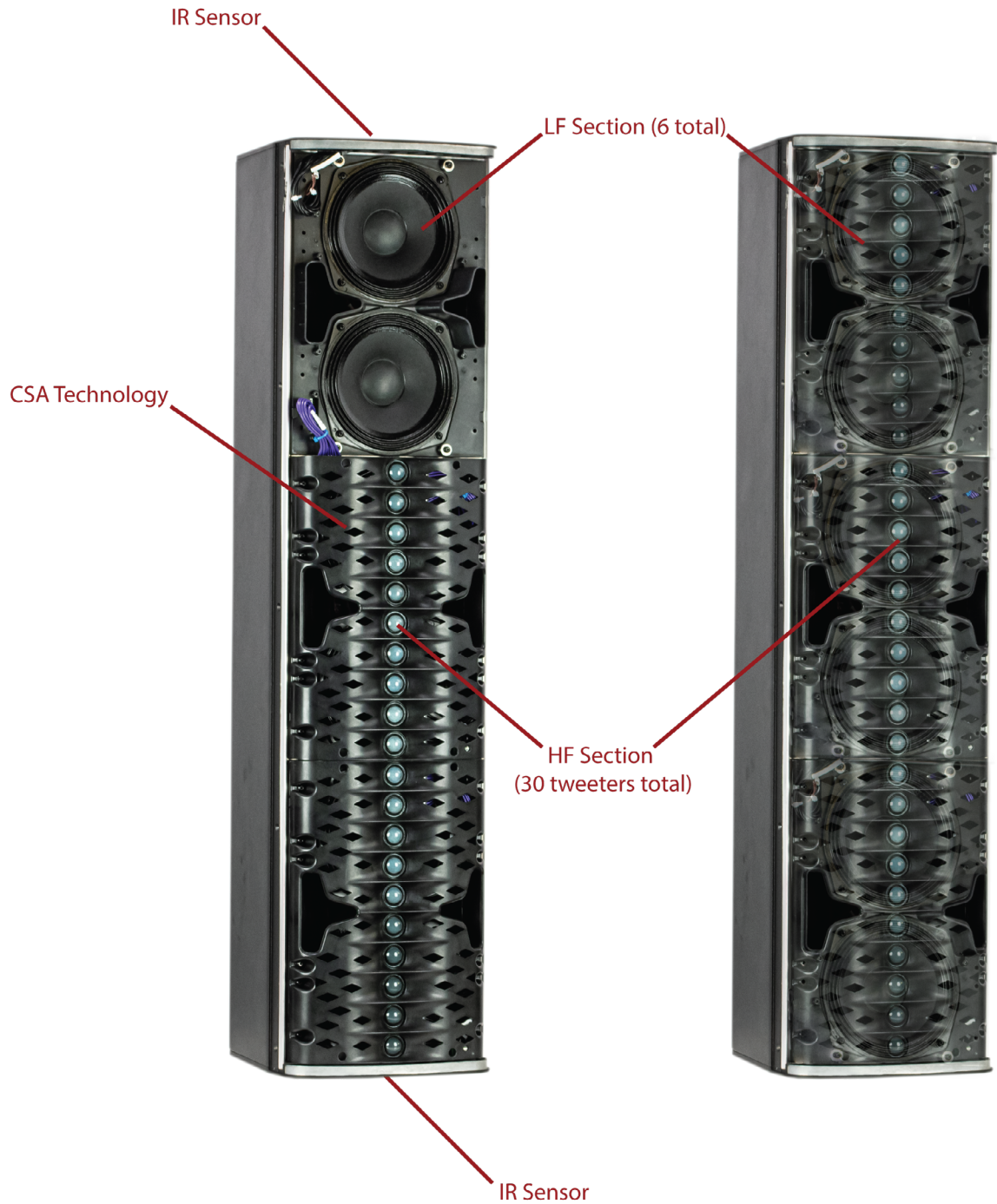

AC6 User Manual

AC6 Walkaround (back)

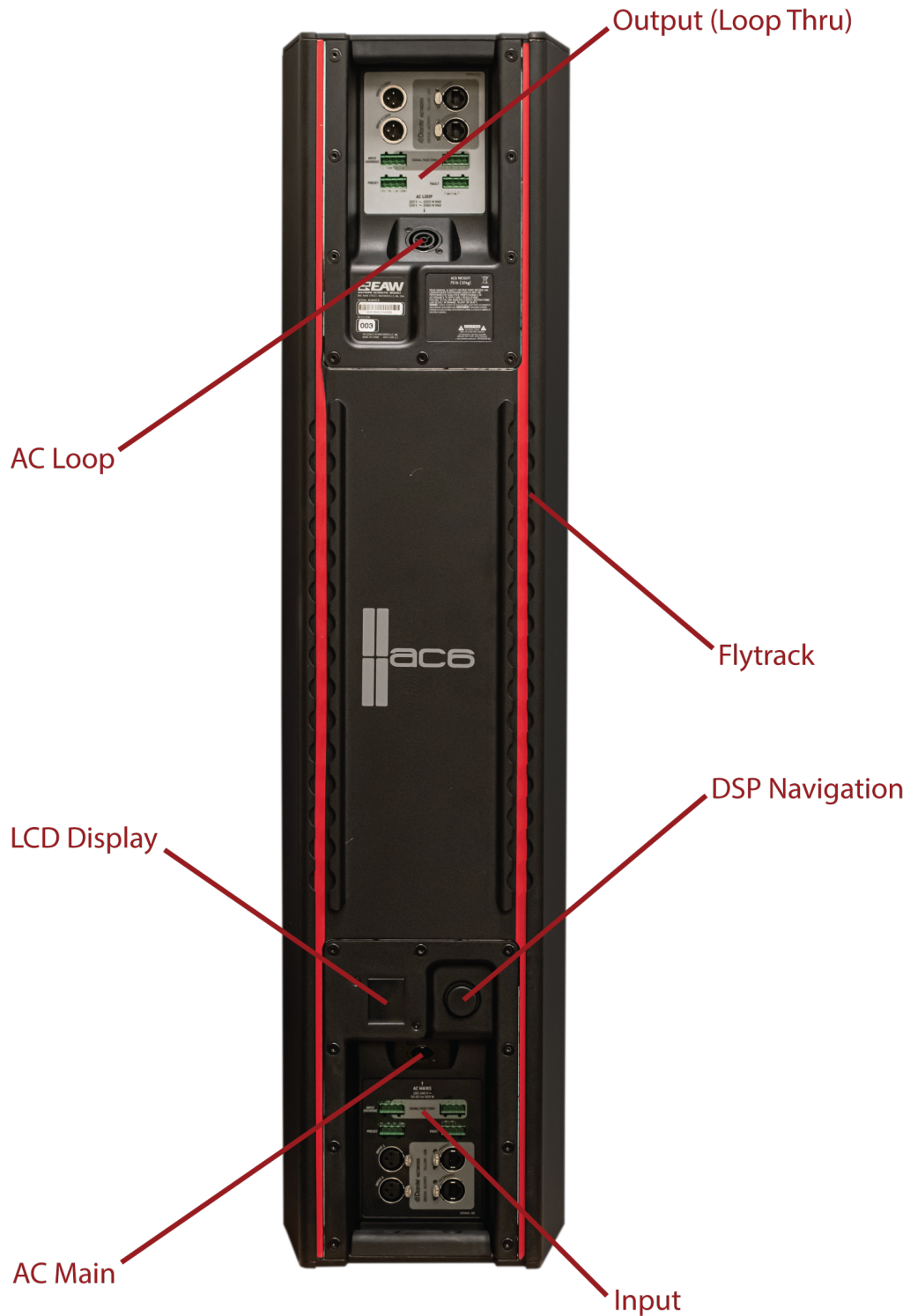

AC6 User Manual

Input Panel

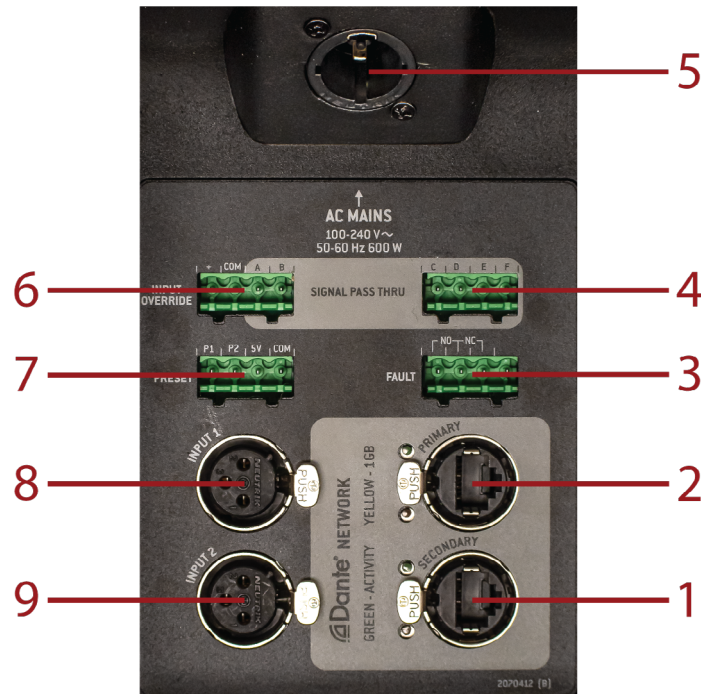

1. Secondary Dante EtherCON™ Connector
2. Primary Dante EtherCON™ Connector
3. Fault: Will set NC/NO open or closed respectively.
4. Signal Pass Thru: Can carry 5-28V control signals through up to 3x modules.
5. PowerCON™ TRUE1™ AC Mains Input
6. **Connect 5V to the + pin to override input. Input override selection can be done on the back panel or within Resolution.**
7. Preset: Using 00/01/10/11 logic to select presets 1/2/3/4.*
8. XLR Audio Input Connector
9. XLR Audio Input Connector

*It is possible to recall ADAPtive Presets 1-4 by using a contact closure to connect 5V to P1 and/or P2.

- Preset 1 is P1 and P2 not connected to 5V
- Preset 2 is P1 connected to 5V
- Preset 3 is P2 connected to 5V
- Preset 4 is P1 and P2 connected to 5V

To switch presets, the system must sense a change. For instance, to recall preset 1, with P1 and P2 not connected to 5V, then momentarily (within 300ms) connect one of them to 5V and then disconnect it.

AC6 User Manual

Loop/Thru Panel

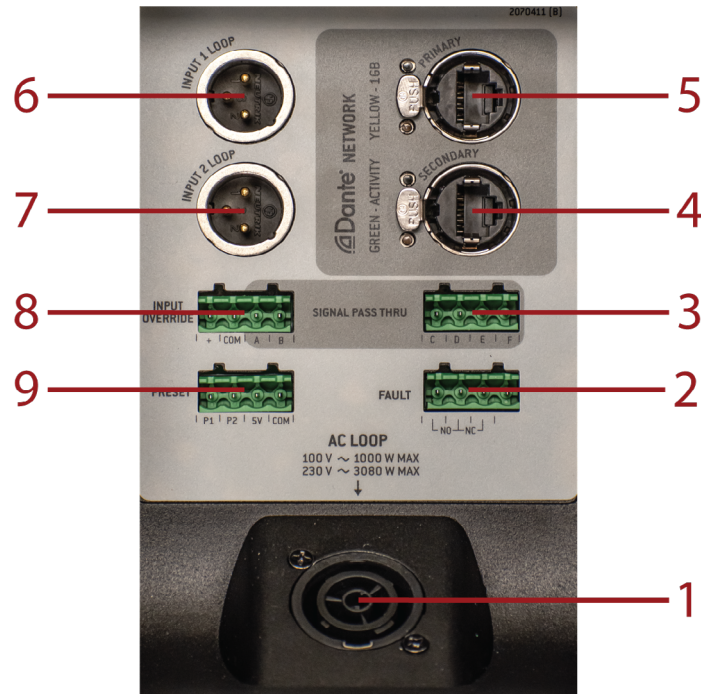

1. PowerCON™ TRUE1™ AC Mains Output
2. Fault: Will set NC/NO open or closed respectively.
3. Signal Pass Thru: Can carry 5-28V control signals through up to 3x modules.
4. Secondary Dante EtherCON™ Connector
5. Primary Dante EtherCON™ Connector
6. XLR Audio Output Connector
7. XLR Audio Output Connector
8. Input Override: Connect the 5V pin to + to override input. Input override selection can be done on the back panel or within Resolution.
9. Preset: Using 00/01/10/11 logic to select presets 1/2/3/4.*

*It is possible to recall ADAPTive Presets 1-4 by using a contact closure to connect 5V to P1 and/or P2.

- Preset 1 is P1 and P2 not connected to 5V
- Preset 2 is P1 connected to 5V
- Preset 3 is P2 connected to 5V
- Preset 4 is P1 and P2 connected to 5V

To switch presets, the system must sense a change. For instance, to recall preset 1, with P1 and P2 not connected to 5V, then momentarily (within 300ms) connect one of them to 5V and then disconnect it.

AC6 User Manual

AC Mains Connection

Connect the supplied AC mains cord to the powerCON® True1 socket on the rear of AC6.

The True1 system utilizes a locking connector. To lock, twist 1/4 turn clockwise after fully inserting it into the AC MAINS receptacle.

Connect the other end to an AC mains supply receptacle, nominally as seen on back panel. If necessary, have a qualified electrician change the cable plug as required for compatibility with the local AC mains receptacle.

WARNING: Before connecting AC6 to the AC mains supply, completely turn down the input signal. If not, there could be excessive and possibly damaging sound levels from the loudspeaker when energized.

There is no power switch. When connected to the AC mains, the loudspeaker will be fully operational, with the output level controlled by the signal source feeding it.

Linking Power

The Neutrik powerCON® True1 AC mains and AC loop connectors are wired in parallel to provide an AC mains inlet and outlet on each NTX & SBX. The AC mains inlet mates with a True1 female connector.

The AC Loop outlet mates with a True1 male



connector. Therefore, to loop the AC mains from enclosure to enclosure, connect an AC mains jumper cable.

A total of three AC6 may be looped in this fashion at 110v, and a total of six units may be looped at 220v. Use an AC loop connector to daisy-chain AC mains power from one enclosure to another.

The maximum ambient operating temperature for AC6 is 45°C.

Audio Connections

Analog Audio

Connect the output from your line-level signal source to the XLR-3F INPUT connector on the rear panel. This is an electronically balanced input. Users must provide their own XLR cables. The XLR-type connectors on the rear of each AC6 is designed for professional audio signal levels, nominally 0 dBu (= 0.775 V). Normally, use the female XLR as the signal input. Use a male XLR as a loop-thru output to connect the same signal input to additional modules.

The wiring convention is as follows:

Pin 1 Shield
Pin 2: +/Hot
Pin 3: -/Cold

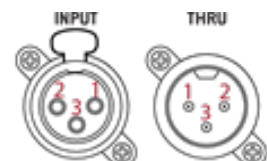

AC6 User Manual

Electrical Warnings

AC MAINS SUPPLY

WARNING: Read all instruction and cautionary notes concerning electrical power in the EAW Loudspeaker Owner's Manual.

Translations

ALIMENTATION SECTEUR

ATTENTION: Lisez toutes les instructions et notes de sécurité sur l'alimentation secteur, dans le mode d'emploi de l'enceinte EAW.

ALIMENTAZIONE AC

ATTENZIONE: Leggere tutte le istruzioni e le avvertenze riguardanti l'alimentazione elettrica, incluse nel Manuale EAW Loudspeaker.

FUENTE DE ALIMENTACIÓN

PRECAUCION: Lea todas las instrucciones y advertencias relativas a la corriente eléctrica que aparecen en el manual de altavoces EAW.

NETZSTROMVERSORGUNG

WARNUNG: Lesen Sie alle Anweisungen und Sicherheitshinweise bezüglich der Netzspannung in der EAW Lautsprecher Bedienungsanleitung.

AC Mains Cable

The AC mains cables supplied mate with the Neutrik® powerCON™ True 1 AC MAINS jack on the loudspeaker. TRUE1 refers to both TRUE1™ and TRUE1 TOP™. Phase in date depends on product.

WARNING: Ensure that AC power supply has a properly grounded safety ground. Failure to follow this warning could cause equipment damage, injury, or death.

Translations

Cordon secteur

ATTENTION : Il se peut que le format de la fiche secteur ne corresponde pas à celui de votre situation géographique. Dans ce cas, faites appel à un électricien agréé pour qu'il remplace la fiche par une autre du bon format. Respectez les normes électriques de câblage locales.

ATTENTION: Assurez-vous que la ligne secteur dispose d'une terre. Le non-respect de cette précaution peut entraîner des dommages aux équipements et des accidents aux personnes pouvant être fatals.

Cavo d'alimentazione AC

CAUTELA: Il connettore del cavo d'alimentazione AC fornito in dotazione potrebbe non essere adeguato per le prese di corrente impiegate nell'area in cui il diffusore viene utilizzato. In questo caso, contattare un elettricista qualificato per sostituire la presa di corrente con una dotata di connessione adeguata. Per il cablaggio, occorre seguire la codifica corretta utilizzata nell'area d'utilizzo.

ATTENZIONE: Assicurarsi che la presa d'alimentazione sia correttamente collegata a terra. Il mancato rispetto di tali avvertenze potrebbe causare danni all'apparechiatura, nonché infortuni alle persone o la morte.

Cable de alimentación

PRECAUCION: El enchufe que viene en el cable de alimentación incluido puede que no encaje en las salidas de corriente de su zona. Si ocurre esto, contacte con un electricista profesional para que sustituya el enchufe problemático y lo cambie por uno adecuado para la salida de corriente. Compruebe que se sigan todas las normativas de seguridad aplicables.

PRECAUCION: Asegúrese que la fuente de alimentación tenga una conexión a tierra correcta. El no cumplir con esta advertencia puede dar lugar a daños en el equipo, en las personas que lo manejen o incluso la muerte.

Netzkabel

VORSICHT: Das mitgelieferte Netzkabel besitzt möglicherweise einen etzstecker, der nicht in Ihre Steckdose passt. In diesem Fall können Sie sich von einem zugelassenen Elektrobetrieb einen passenden Netzstecker unter Berücksichtigung der jeweils gültigen Vorschriften montieren lassen.

WARNUNG: Stellen Sie sicher, dass er Schutzleiter der Netzsteckdose ein gute Verbindung zur Erde hat. Nichtbeachtung dieses Hinweises kann zu Schäden am Equipment, zu Verletzungen oder zum Tod führen.

AC6 User Manual

Signal Processing

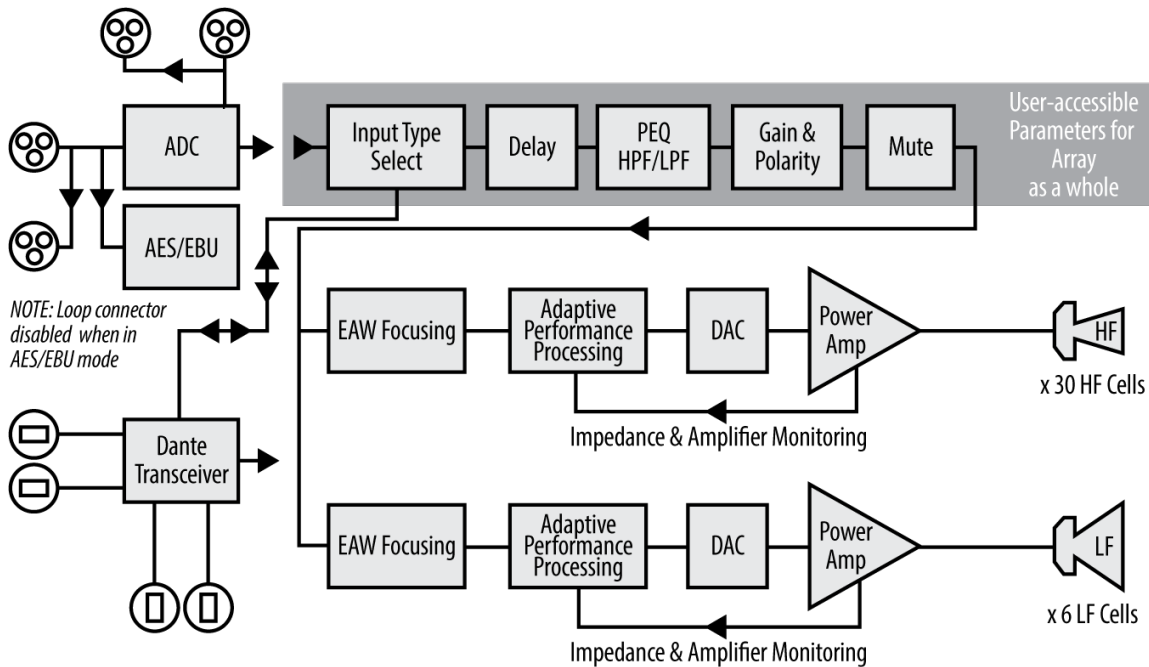

Each AC6 module contains three levels of signal processing: non-user-accessible, user-influenced, and user-accessible.

AC6 module performance (frequency response, beamwidth consistency, output level capability, etc.) depends on crossover and other processing settings fixed within the built-in digital processing. These parameters are not user-accessible.

Adaptive Performance™ translates venue parameters entered by users into Resolution into digital signal processing settings that optimize system response to provide the desired coverage. Though not directly editable by users, these parameters are calculated based directly on user input.

Resolution software also provides access to standard, user-adjustable DSP functions to modify the overall performance of the array to accommodate a particular program content, venue characteristics, or personal taste in voicing. These include low-pass filter, high-pass filter, shelving and parametric EQ, gain, delay, and polarity. It also provides access to signal routing (analog, AES/EBU or Dante™) options. Please note that signal processing is applied to each Anna array and cannot be user-implemented on individual loudspeakers because this would compromise directional performance.

AC6 User Manual

Operating Limits

While the AC6 processing includes robust driver and amplifier protection algorithms and circuits, it is ultimately the responsibility of the audio system operator to operate the loudspeakers within their capabilities. This is the only way to ensure that loudspeakers are not stressed beyond their limits to the point of damage or failure.

Operation of loudspeakers beyond their capabilities usually includes, but is not limited to, one or more of the following conditions:

- ▶ Severe amplifier clipping
- ▶ Noticeable distortion
- ▶ Mechanical noise (such as cones bottoming out)

EAW strongly recommends that users only operate an AC6 system using Resolution 2 software to monitor output levels. Though the on-board DSP includes 'soft' limiting, IT WILL NOT PROTECT THE SYSTEM UNDER ALL CONDITIONS. It is still possible to damage an AC6 system with excessive drive levels.

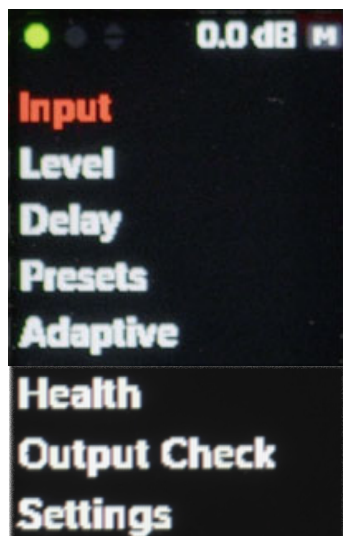

Rear Panel Home Screen and Menu Navigation

The AC6 Loudspeaker's LCD Display and DSP Navigation / Edit Wheel are used to monitor the loudspeaker's status and adjust its DSP settings. Rotate the DSP Navigation / Edit Wheel to change the highlighted sub-menu or to change parameter values. Press it to select a sub-menu or to enter values.

Upon power on and initialization of the loudspeaker the Main Menu is displayed. The network LEDs on the upper left that display during menu navigation indicate the following:

- ▶ **GRAY:** Not plugged in, or no signal on the cable (network is not active)
- ▶ **RED:** Link UP, Dante Input selected, Dante Mute is ON
- ▶ **AMBER:** Link Up, Network active

If the Home Screen is displayed, pressing or turning the DSP Navigation / Edit Wheel reveals the Main Menu.

Input

Input allows for configuring input assignments to analog, AES, or Dante.

Level

Selecting Level allows adjusting to the loudspeaker's output level in 0.5 dB increments ranging from -10 dB to +10 dB. Rotating the DSP Navigation / Edit Wheel changes the level value and pressing it returns to the Main Menu. After 5 seconds have passed with no change to the Level parameter the Home Screen is displayed.

AC6 User Manual

Delay

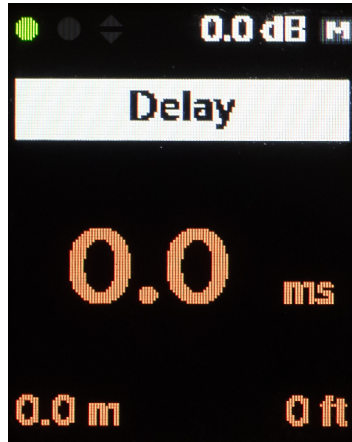

Selecting Delay allows adjusting to the loudspeaker's alignment delay in 1ms increments ranging from 0 to 150 ms in 0.1 ms increments between 0 and 10 ms and in 1 ms increments above 10 ms. For reference, the equivalent distance is displayed in meters and in feet.

Rotating the DSP Navigation / Edit Wheel changes the delay value, and pressing it returns to the Main Menu. After 5 seconds have passed with no change to the Delay parameter, the Home Screen is displayed.

Presets

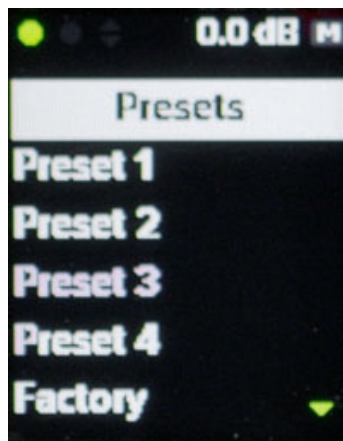

It is possible to save up to four user defined presets with AC6. Each preset will be saved in the amp module and may be recalled either from the LCD screen or by utilizing preset manager in Resolution 2 software. To save a new preset using the LCD back panel, use the scroll wheel to select which preset slot will be utilized, then save. The Factory option will return AC6 back to the state in which it was shipped.

Adaptive

Allows for the ADAPTive algorithm to be accessed from the rear panel without the need of Resolution Software. To begin, use jog wheel to scroll down to **Adaptive** then click once.



Next, choose to **Set Coverage** or **Clear** current parameters. Choose **Status** to view current parameters uploaded.

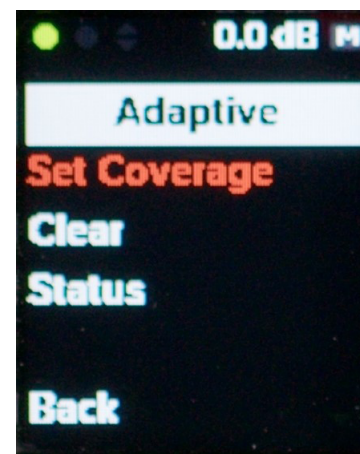

AC6 User Manual

When **Set Coverage** is chosen, a multi-option process initializes. Scroll through the menu to ensure all parameters are identified and configured as needed and defined by the venue and array position. Click OK to initialize and uploaded parameters to the entire array.

NOTE: If there are multiple AC6 in one array, this only needs to take place on one AC6 module. The parameter upload will factor in all AC6's defined as single source.

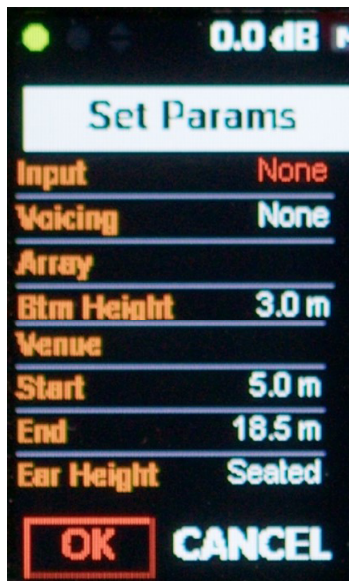

Output Check

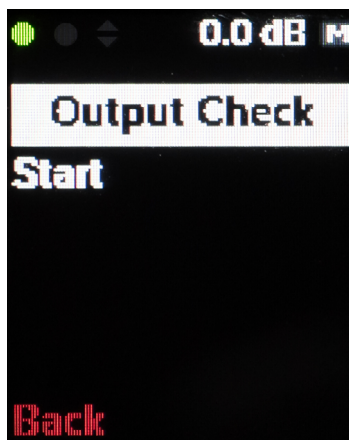

Transducers and amplifier channels can quickly be checked without the need for an external noise generator and any associated cables or test equipment. Individual transducers and amplifier channels can be tested manually or via an automated sequence.

Initiating Output Check automatically or manually will cause the loudspeaker to emit pink noise. To ensure against potentially dangerous exposure to high sound pressure levels, it is recommended that all persons exposed to equipment capable of producing high sound pressure levels use hearing protectors while the equipment is in operation.

1. Rotate the DSP Navigation / Edit Wheel to select Start.
2. Press the DSP Navigation / Edit Wheel to initiate the automatic test procedure.
3. A 2-second pink noise burst is emitted per transducer.
4. When a channel is emitting pink noise, its status changes to indicate exact transducer being tested
5. Auto status changes to "Start" to signify the end of the Output Check cycle.

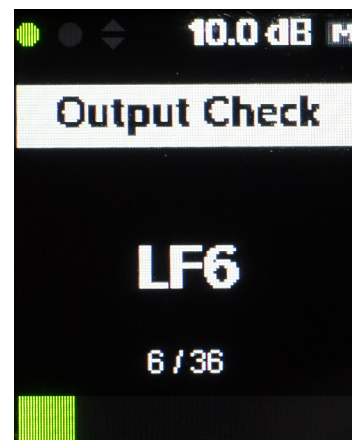

AC6 User Manual

Testing specific drivers or channels

Once the test has started, it's possible to navigate to a specific driver using the DSP wheel

1. Rotate the DSP Navigation / Edit Wheel to select Start.
2. Press the DSP Navigation / Edit Wheel to initiate the automatic test procedure.
3. Use DSP Wheel either clockwise or counter clockwise to locate specific driver or channel.

Settings

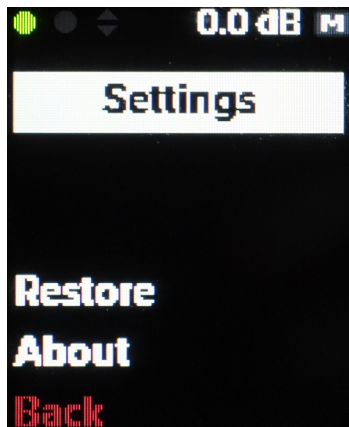

From the Settings menu, it's possible to restore the loudspeaker to factory default settings, and view network address and firmware version information.

Restore:

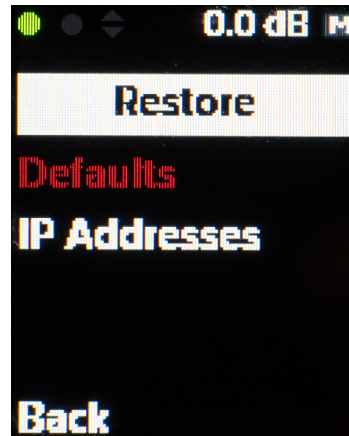

Factory or network settings can quickly and easily be restored. This is convenient for managing rental inventories or for resetting a mobile production system prior to deployment to the next venue or job site. It can also be used when troubleshooting loudspeakers exhibiting distorted audio, poor frequency response, low output, etc. Certain settings in the loudspeaker can only be accessed via EAW Resolution. These settings can be the cause of what may appear to be poor performance when the speaker is isolated on the test bench, or when compared to other units in inventory. All settings are reset to factory default when the Restore procedure is performed.

4. Rotate the DSP Navigation / Edit Wheel to select **Defaults** or **IP Addresses**.
5. Select No to prompt to return to the Settings sub-menu without changing any of the loudspeaker settings.
6. Select Yes to prompt to restore factory or network default settings and return to the Main Menu.

AC6 User Manual

About:

The About screen provides information about the loudspeaker's current input source, model number, firmware and network address details.

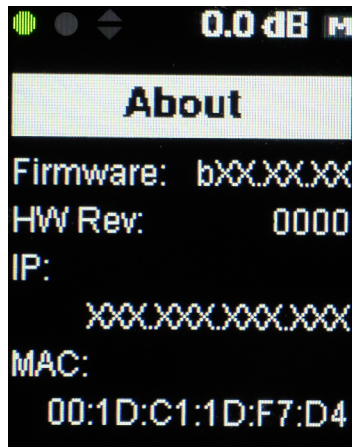

Home Screen

After 5 seconds have passed with no turn or press of the DSP Navigation / Edit Wheel the Home Screen is displayed showing primary settings, levels and statuses at a glance.

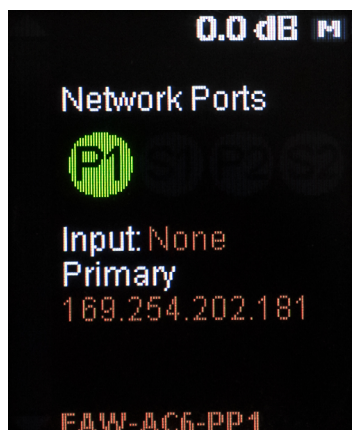

The Control IP is the IP address assigned to the modules DSP.

Three indicators are listed below the Control IP. A & B represent the two Dante inputs.

- ▶ **GRAY:** Not plugged in, or no signal on the cable (network is not active)
- ▶ **RED:** Active network connection with speed
 - ▶ (ie two speakers connected together but not to anything else).
 - ▶ Normally, Ethernet Green LED ON, Yellow LED OFF
- ▶ **AMBER:** Active network connection, speed is less than 1Gbps
- ▶ **GREEN:** Active network connection with 1Gbps network speed

Input will indicate whether a Dante or Analog signal is being detected. This can be toggled in the Resolution or changed by assigning/unassigning in Dante Controller.

The Dante IP is both the primary and secondary IP address assigned to the Dante Card. Under the Dante IP, is the name that has been configured for the module in Dante Controller.

Network Topologies

Networks, by definition, offer flexibility to the user; many approaches can work. Users can create both redundant and non-redundant networks for control and audio signal. The cabling, equipment and setup requirements vary for any given design. The two examples below represent starting points from which individual users would build their own specific solutions.

AC6 User Manual

Fully Redundant - Recommended

The fully redundant system uses two network pathways from the on-ramp to each AC6 module. EAW recommends that users employ two independent on-ramps, as well as a computer with two independent network interface cards (NICs) for complete redundancy. Otherwise, a single Dante™

on-ramp would connect to both the primary and secondary networks. This would create a single point of failure, as would a single computer network interface.

By connecting from FOH to the network at two different locations (Primary at one end of the network, and Secondary at the other), the redundant method also protects the system against failures of an entire Distro Rack.

Below is one example of how a redundant network can be configured, and is our recommendation. However, there are other various methods to achieve redundancy. To learn more, please refer to [Audinate](#)

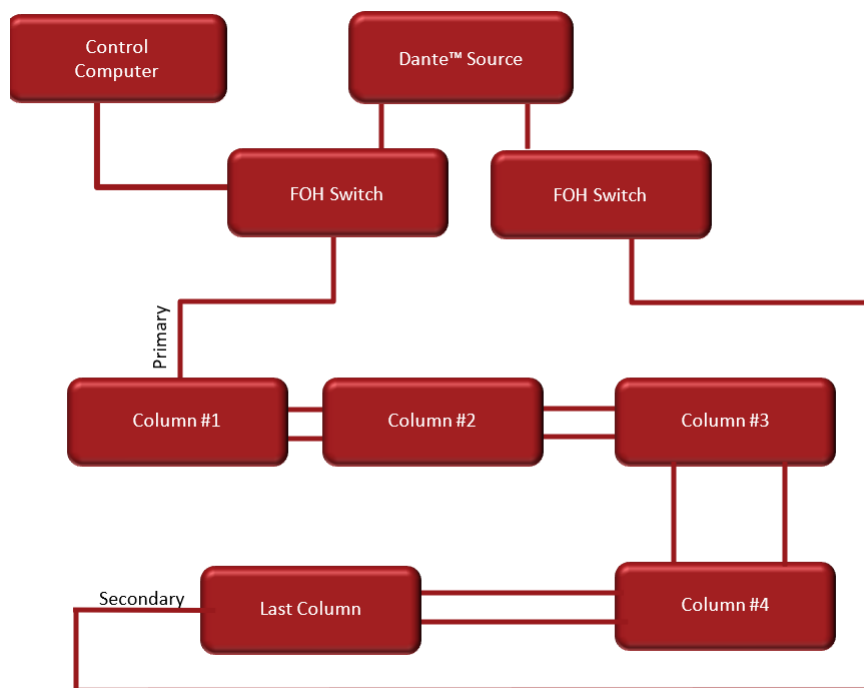

AC6 User Manual

Non-Redundant

In this scenario, each AC6 module uses a single connection to the network. A switch at the front-of-house (FOH) position connects both the control computer and Dante™ on-ramp to the network. A single CAT5e connection links the FOH position to the first column and subsequent columns are linked using the “Thru” ports. All connections carrying audio data should be 1000BASE-T (Gigabit), including the control computer.

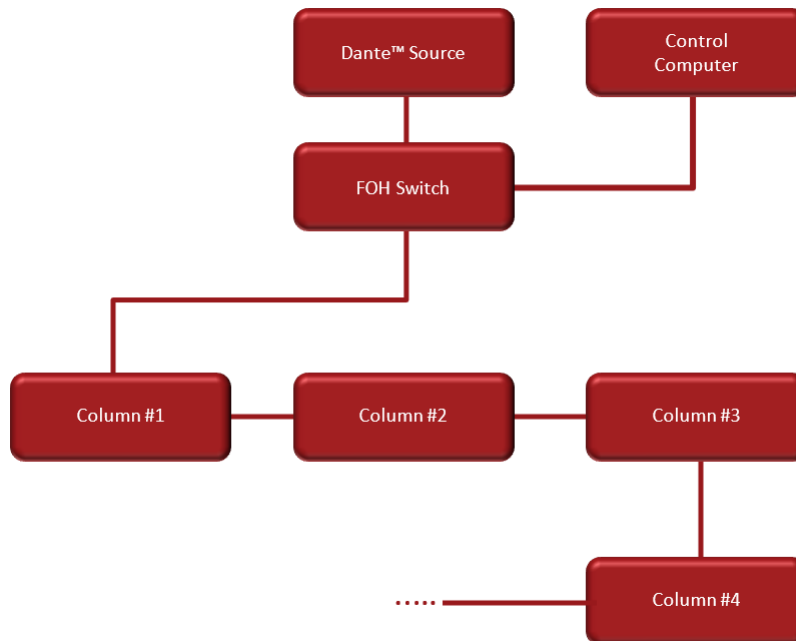

A Further Look into Dante™

Introduction

Dante – Digital Audio Network Through Ethernet – is an industry standard in digital audio networking, delivering unmatched audio quality, extremely flexible routing and offers significant cost savings compared to traditional analog cable runs.

AC6 loudspeakers may be connected to any Dante-enabled audio network. As such, it is a perfect solution for connecting to a Dante-enabled mixer.

With flawless interoperation with hundreds of Dante-enabled products, the Dante connectors truly expand the AC6Series' functionality and application-flexibility in any professional environment.

AC6 User Manual

Array Design

Software

EAW Resolution 2 software is designed to control ADAPTive systems. For advanced functions like in-venue optimization, supplemental software such as Rational Acoustics® Smaart™ may be desired, but this is not required for basic system operation.

Always ensure that your EAW Resolution software and AC6 firmware are up-to-date.

For a complete list of recommended system requirements, please refer to the [Resolution 2 help file](#).

Using EAW Resolution™

EAW Resolution is the key to determining the optimal array configuration for any application. Rooted in EAW's proprietary FChart modeling and calculation engine, Resolution allows users to easily model any venue and visualize a wide variety of array designs to determine what particular array configuration is best suited to the venue.

Users simply need to define the array position, allowable trim, minimum clearance, and quantity of modules available and use the Array Assistant to determine the optimal array configuration for a given venue. In many situations no further prediction work will be necessary for optimal results. Users can also adjust the results after running the Array Assistant by manually adding/removing modules or adjusting coverage and observing changes in predicted results. In this way Adaptive arrays can be optimized for any application.

Additionally, Resolution interfaces directly with Adaptive Systems via the Dante protocol, allowing users to easily upload the processing parameters for their system directly from their model to the physical

array, adjust equalization and coverage, and monitor all Adaptive components in real time.

No additional software is necessary to use Adaptive systems.

Please visit www.eaw.com to download the latest version of Resolution.

How Array Length Affects Directivity

It would be beyond the scope of this guide to go into the physics of how line arrays behave. Regarding vertical directivity, AC6 behaves similarly to any true line source. The difference with Adaptive products is their ability to define that directivity dynamically and across the entire audible spectrum.

The key to directivity is array length. This should not be confused with the number of drivers. A properly designed line array system will exhibit the same directivity from the same physical length regardless of whether this length is made up of 8", 10", 12" or 15" components. The determining factor is the length of the array itself and how that length affects the wavelength being produced.

The samples on the next page show three array types in the same venue. The first array is very short with only 1 x AC6 modules being deployed. The contour line feature in Resolution has been used to clearly show the definition of the vertical contour at 125Hz. It is clear that with this array length, the 125Hz frequency is seeing only slight directivity control.

AC6 User Manual

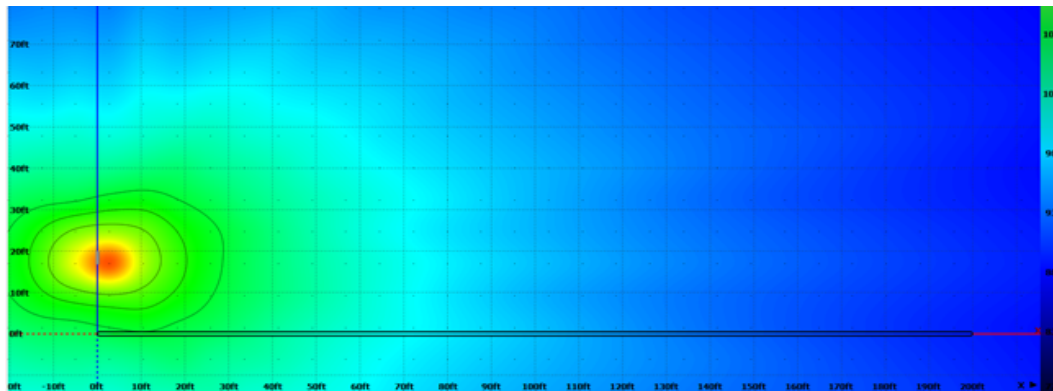

The second image demonstrates what would happen with the same frequency in the same venue but with an AC6 array of 2x modules instead of 1x. It is quite clear how much more directive the vertical has become in this image and if we continue to add modules to the array, the effect will become more pronounced.

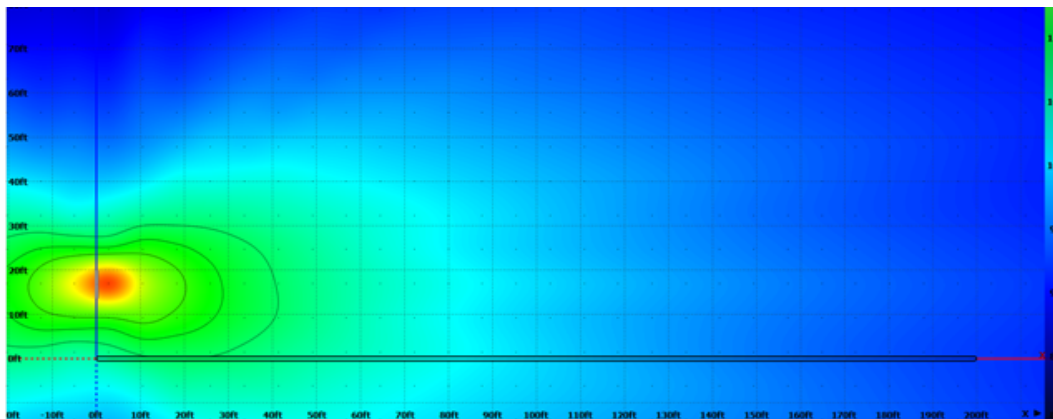

Finally, we see the result when 4x AC6 is deployed. This array of AC6 produces an extremely tight vertical pattern at 125Hz across this listening area. If directivity at lower frequencies is required for the application, array length must be considered.

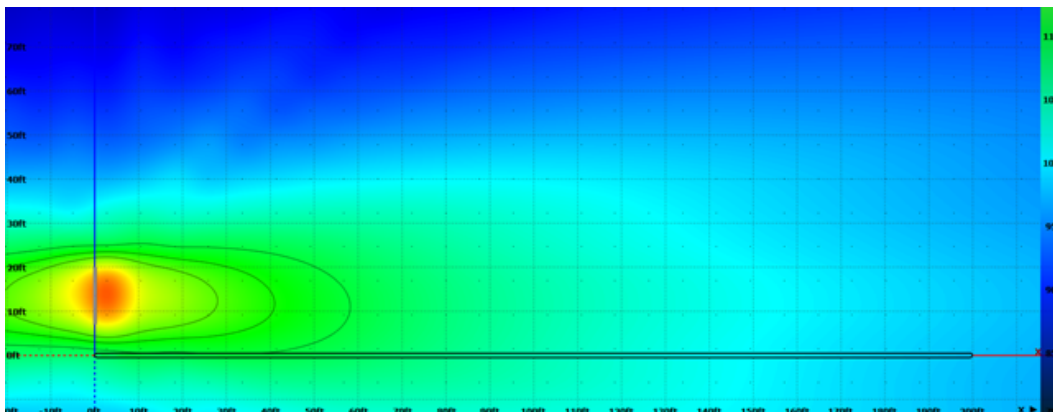

AC6 User Manual

Venue Design Examples

The following section contains a variety of venue examples with recommended systems for each. The venue type, capacity, recommended system size and expected SPL levels are summarized in the table below. These are not hard-and-fast rules, but should serve as a starting point or benchmark for similar system and facility designs.

SIMPLE CHURCH (60' X 40' - SEATING CAPACITY 260 PEOPLE)

Equipment List

- 2x AC6
- 2x SBX118

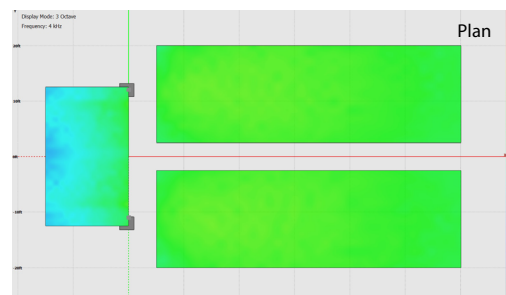
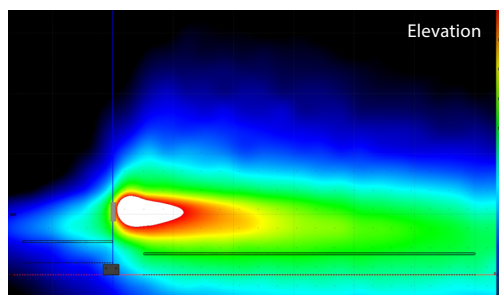
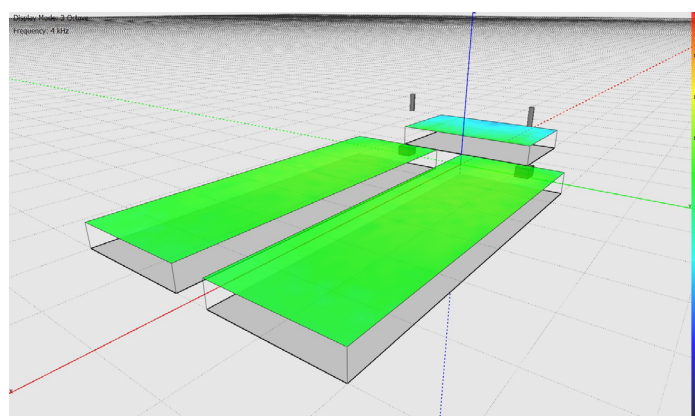
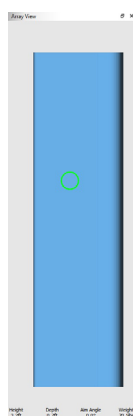

AC6 User Manual

AUDITORIUM (70' X 80' - SEATING CAPACITY 510)

Equipment List

- 4x AC6
- 2x SBX218
- 1x MKD1096
- 4x JF60z
- 1x UXA4410

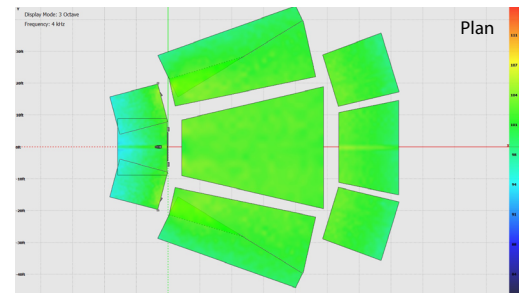
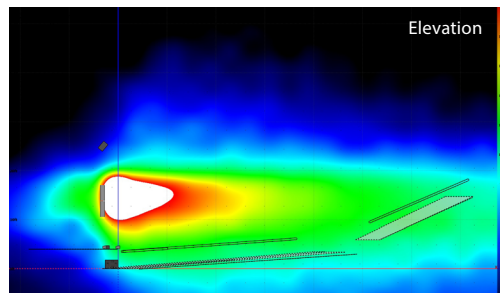
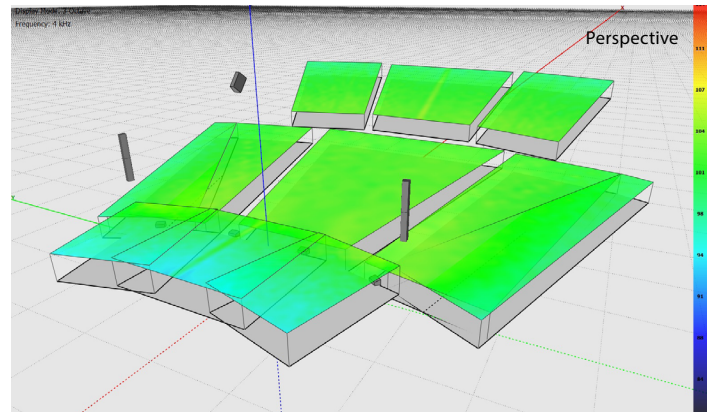
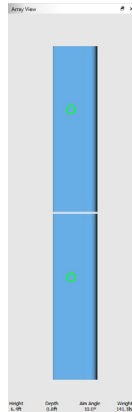

THEATER (70' X 75' - SEATING CAPACITY 670 PEOPLE)

Equipment List

- 4x AC6
- 2x SB828P
- 7x JF60z
- 2x UXA4410

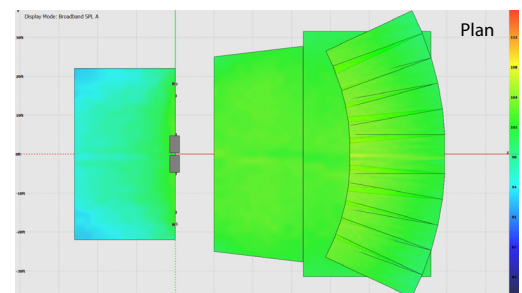
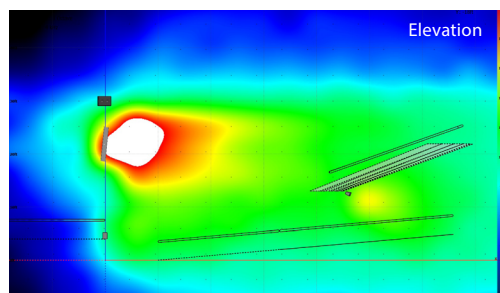
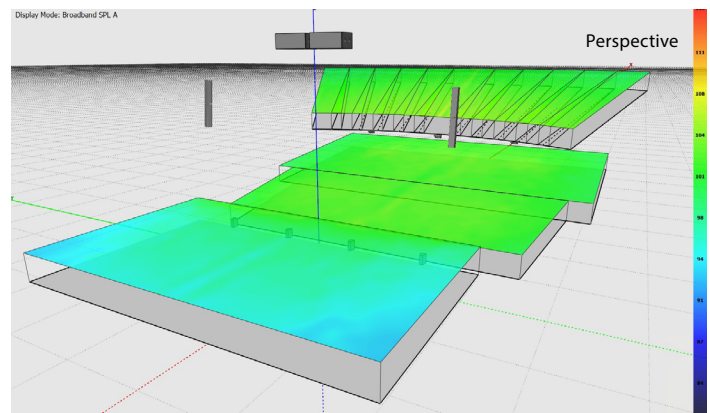
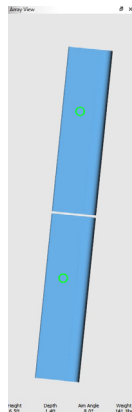

AC6 User Manual

GROUND STACKED (60' X 60' - SEATING CAPACITY 400 PEOPLE)

Equipment List

- 2x AC6
- 2x OTTO

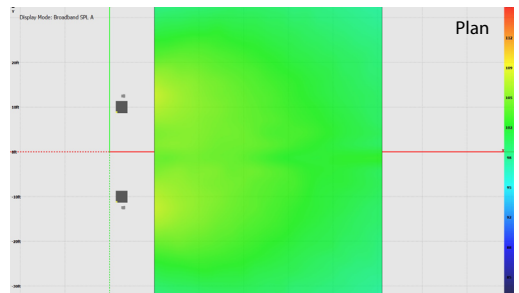
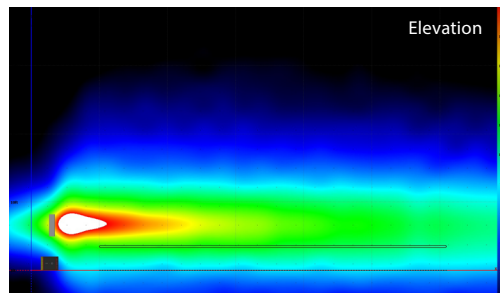
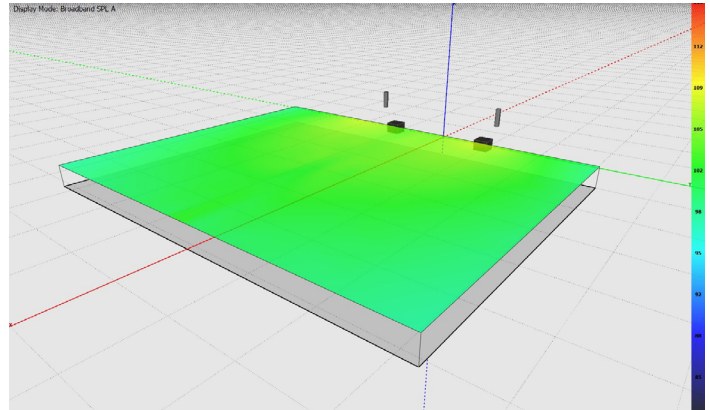
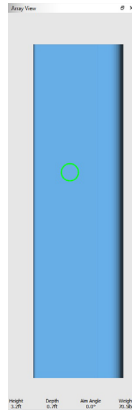

Going Online with AC6

Before going online, be sure the computer is connected to the same Ethernet network as the networked loudspeaker system. Communications is established by clicking Network on the Menu bar and selecting Connect. Resolution 2 will then search for any

AC6 devices on the network and displays them in the Online Devices list. This list will include your computer running Resolution 2. [Click here for a tutorial video explaining how to go online with ADAPTive Systems.](#)

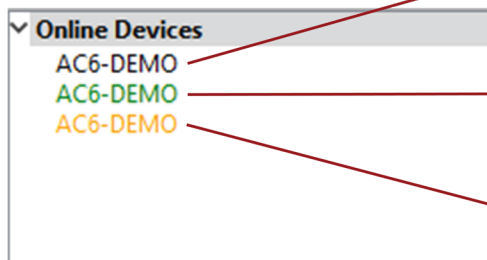

Networked Module Black indicates module appears on the network but has not been assigned to any array in the model.

Networked Module Green indicates module assigned to modeled array and properly connected.

Networked Module Orange indicates module out of sync with the Resolution model

AC6 User Manual

AC6 devices are grouped according to how they are physically arrayed, so if you have assembled an array of two AC6 in a single vertical column for example, those will be listed as:

Array #
Column 1
AC6-Module-#####
AC6-Module-#####

If an array does not automatically group; right click Online Devices select Refresh Neighbor List

The names of the individual modules in that Column will be listed in the order they are physically arranged. Stand-alone modules will be listed individually.

Assigning Physical Arrays/Modules to Modeled Arrays/Modules in Resolution

EAW's recommended best practice for AC6 systems is to create your venue in Design View and determine the optimum arrays needed

to provide the coverage you will need prior to assembling, flying, and connecting to the system. This will ensure you know how the Arrays will need to be configured. However, this is not required, and you can simply fly the arrays and connect Resolution 2 to your system with a blank Venue loaded if needed. [Click here for a video on how to design a system in Resolution 2.](#)

It is best to at least enter a simple representation of the area you intend the System to cover. Adding arrays in the appropriate positions prior to going online will speed connection time allowing you to upload settings as soon as you associate a modeled Array with its physical Array.

If arrays are not defined in the Venue, then simply click on each Array in the Online Devices list and drag them over to the Network Configuration desktop. This will open the Array Assistant dialog. After the settings are entered click finish. Resolution 2 will create an icon with the name of the Array, the list of arrayed modules in each Column in the Array, an Array Mute button, Input Level and Gain Reduction meters.

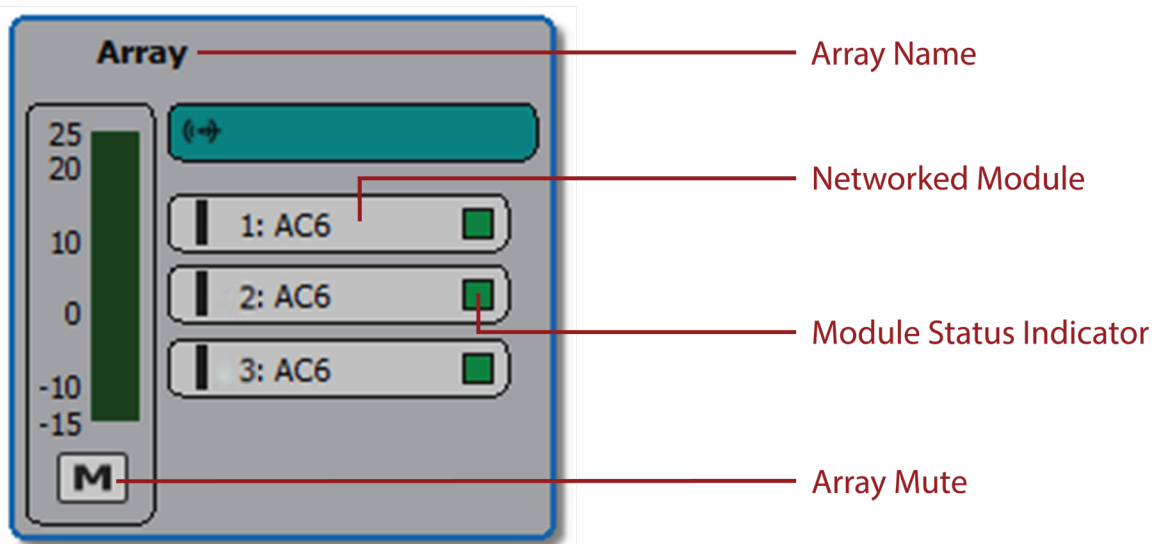

AC6 User Manual

It is possible to edit the X,Y,Z physical location, Min Trim, Max Hang and Aim Angle in the Properties pane while that Array is selected.

If a venue and arrays have been created in Resolution, then representations of the Arrays and Modules in the model will be displayed in the Network Configuration View as grey boxes. Each module in the array will have a small indicator square that reports each module's status.

- A question mark indicates that no physical module has been associated with the module in the model.
- A Yellow box indicates a module that has gone offline.
- A Red box indicates a module previously assigned that was not found upon reconnecting to the Network.
- A box that occasionally flashes Green indicates the module is successfully communicating with Resolution.

Unassigned modeled Arrays will have the list of modules or loudspeakers included in the Array while non-arrayed loudspeakers will be shown as individual boxes with only one device listed. Arrays will be shown with the modules in Columns and the meters.

A physical AC6 Array in the Online Devices list can be assigned or associated with a modeled Array in the model by simply clicking on the Array in the list and dragging it on to the appropriate modeled Array.

Note: the physical Array and modeled Array must include the same quantity and arrangement of modules).

Assign all physical Arrays to modeled Arrays until all Arrays have been assigned.

Managing AC6 in Resolution

Once a physical Array has been associated with a modeled Array, the individual modules listed in the Array will be graphically arranged in Columns and a small square "indicator light" for each module. These indicators will periodically flash green to confirm that Resolution 2 has established active communications with each Anya module.

Clicking an Array in the Network Configuration Desktop will display its properties in the Properties View window (if the Properties View window is opened) and can be edited as explained in the Properties View chapter.

Array Processing can be displayed and edited in real-time by double-clicking the EQ graph at the top of the Properties View window.

Right clicking an Array will open a menu with options to open Array Processing, Unassign All, Edit the array (which will launch the Array Assistant), Clone the array, Save Array Preset, Lock array movement, or Remove array. These mirror functions available in the Project Explorer and Properties panes.

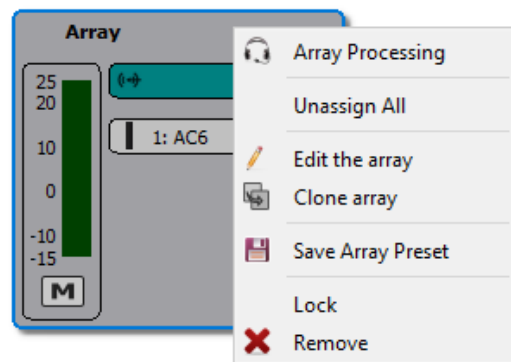

AC6 User Manual

Double clicking the teal input assignment button will open the Array Configuration dialog.

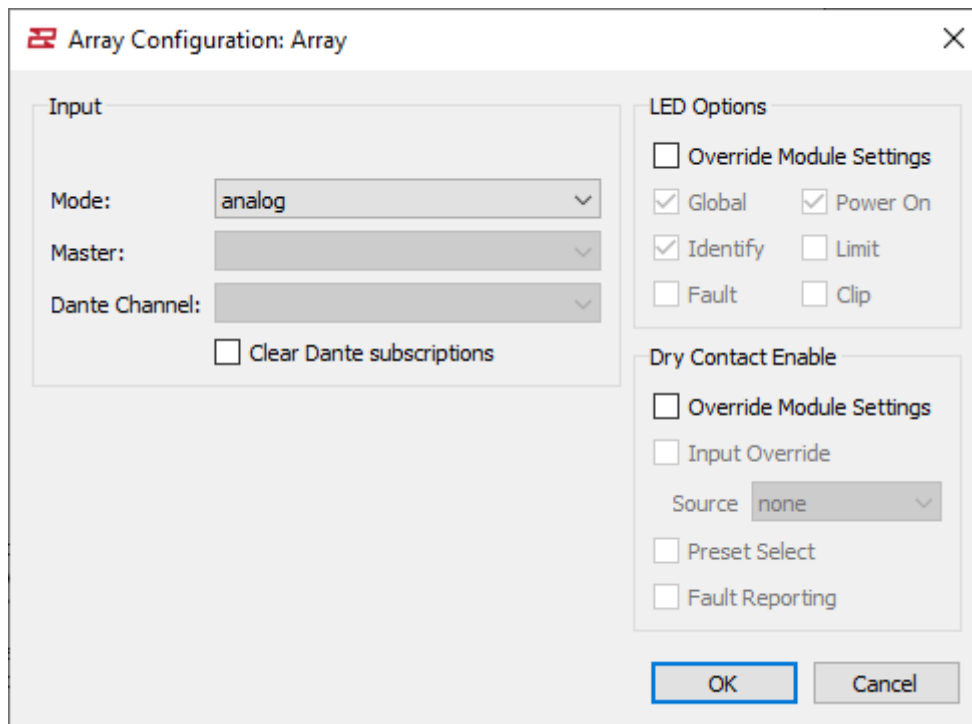

Right clicking a module in an Array will open a menu with options to Insert Item Above, Insert Item Below, Unassign, or Remove Array Item.

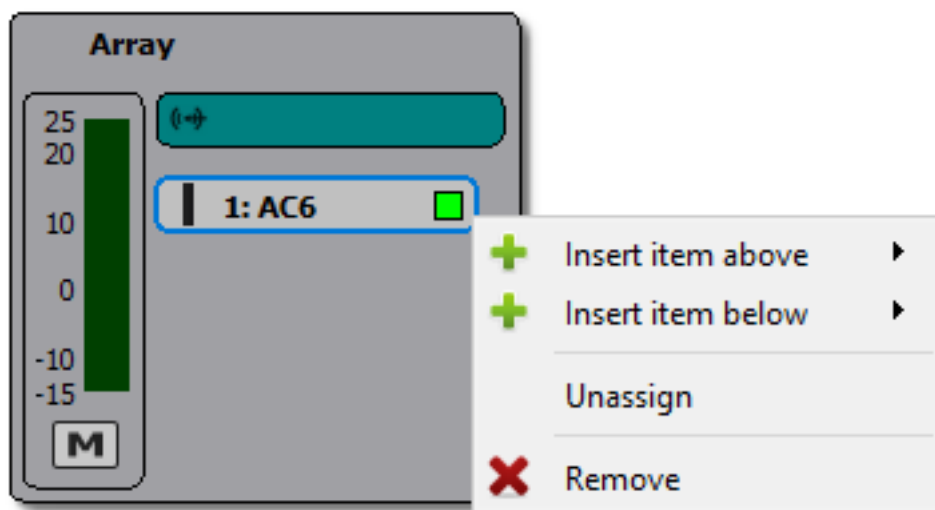

AC6 User Manual

Double clicking a module will open the Diagnostics Window for that module

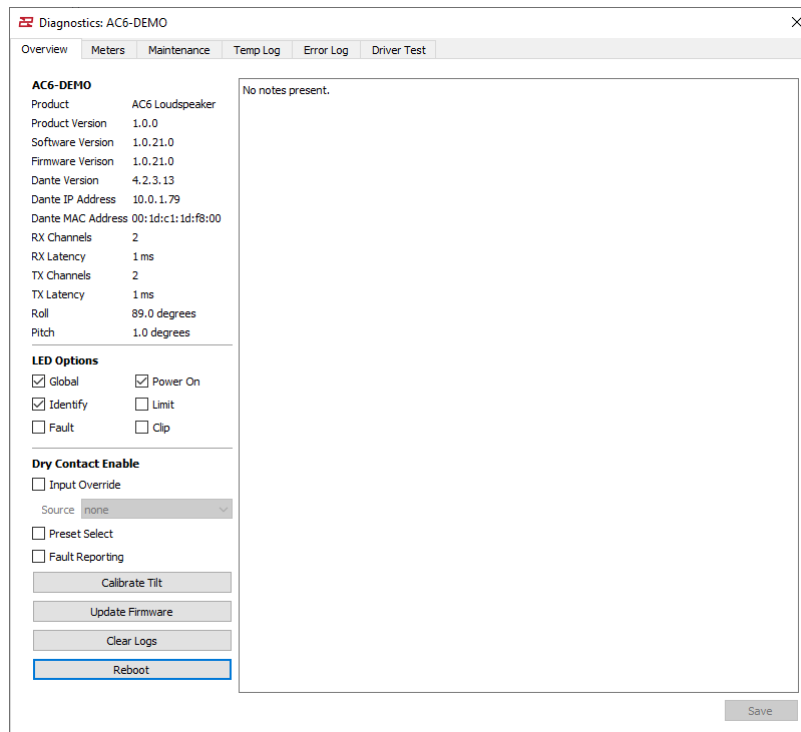

Updating Firmware on AC6

NOTE: Before starting Firmware update, please turn the Windows Firewall off.

NOTE: It is highly recommended you run the firmware update with a DHCP server connected to the network.

Select Tools>Firmware Manager:

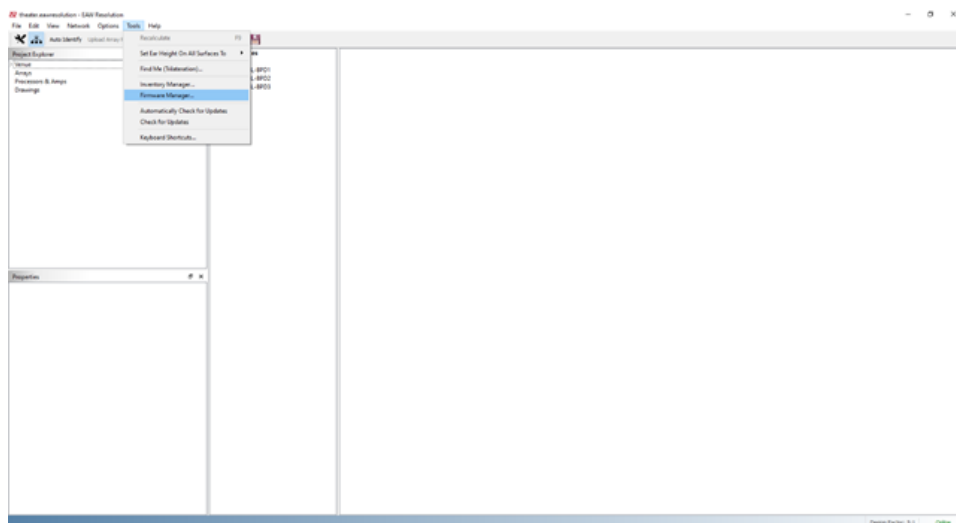

AC6 User Manual

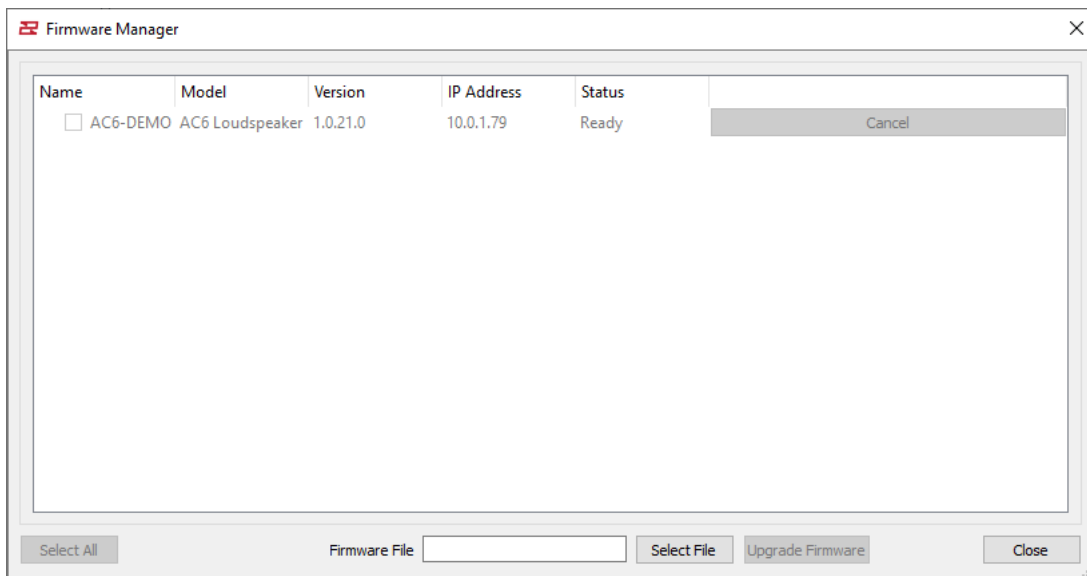

Select the firmware file (.eawfw) in C:\ProgramData\EAW Resolution (Windows must be set to show hidden files and folders):

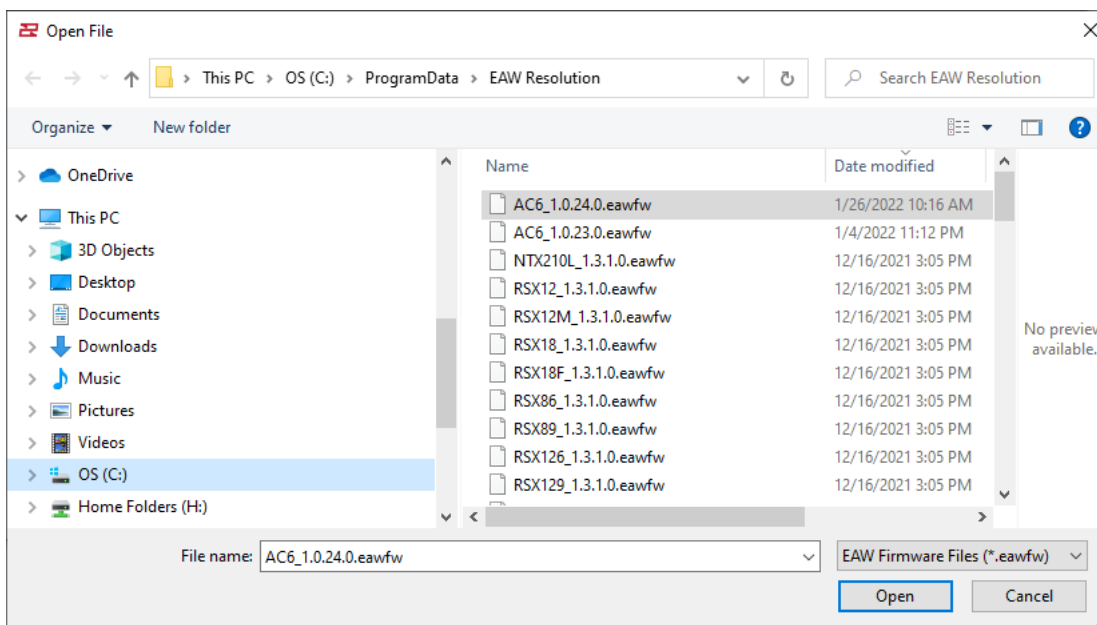

AC6 User Manual

Select the AC6 modules you wish to upgrade (or select all):

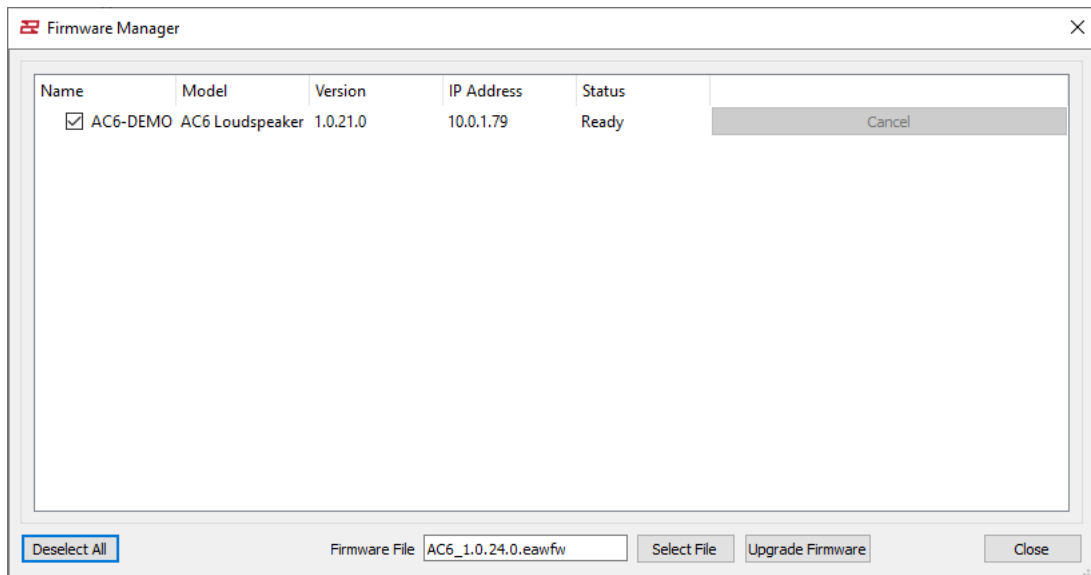

Select Upgrade Firmware.

The upgrade is complete when the status indicates 'Finished'. The status will return to 'Ready' about 30 seconds after it has finished.

Resolution 2 System Requirements

EAW Resolution 2 requires an IBM®-compatible PC with Windows 10® operating systems, including a standard Ethernet port to connect the computer to the network and control NTX & SBX loudspeaker modules. Though processor speed and memory size primarily impact only calculation time, the following specifications are recommended for useful operation:

	MINIMUM REQUIREMENTS	RECOMMENDED SPECIFICATIONS
Processor	2.2 GHz Dual Core Processor	2.8 GHz Quad Core Processor
Memory	2 GB RAM	8 GB RAM
Screen Resolution	1024 x 768 display resolution	1920 x 1080 display resolution
Operating System	Windows 10	Windows 10
Storage	1 GB available HD space	1 GB available HD space

****Currently, Resolution does not support 4k screens or Windows 11****

AC6 User Manual

Mounting & Rigging AC6

IMPORTANT SAFETY INSTRUCTIONS – READ THIS FIRST

Safety Instructions

Read and heed all warnings and safety instructions in this manual before using this product. Failure to follow these precautions may result in damage, injury, or death.

- 1) Read these instructions.
- 2) Keep these instructions.
- 3) Heed all warnings.
- 4) Follow all instructions.
- 5) Clean only with a dry cloth.
- 6) Install loudspeaker in accordance with the manufacturer's instructions.

7) Do not install near any heat sources such as radiators, heat registers, stoves, or other apparatus that produce heat.

8) Only use attachments/accessories specified by the manufacturer.

9) Refer all servicing to qualified service personnel. Servicing is required when the apparatus has been damaged in any way, does not operate normally, or has been dropped.

10) Use personal protective equipment not limited to gloves, safety goggles, ear protection, and lifting supports.

Suspension Warnings

WARNING: Suspending anything, especially overhead of people, should be done with extreme caution. Always engage the services of a certified professional who is qualified to determine the requirements for and to implement overhead rigging. Only persons with the knowledge of proper hardware and safe rigging techniques should attempt to suspend loudspeakers overhead. Failure to follow these precautions may result in damage, injury, or death.

AC6 User Manual

Wall Bracket Instructions

Tools needed: 10mm wrench or hex driver, 4mm allen

1. Inventory

Before beginning installation, inventory your available hardware to items listed.

Item	Description	Quantity
A	AC6 Wall Bracket	1
B	AC6 Cabinet Bracket Assembly	1
C	Cosmetic Cover	1
D	M6 x 20 screws	2

2. AC6 wall bracket limits of use

a. The AC6 Wall bracket is designed to suspend each corresponding AC6 Series loudspeaker with a design factor of 10:1 to meet or exceed most global suspension regulations. Below are the maximum working load limits at 10:1, 7:1 and 5:1 Design Factors.

Design Factor	Maximum Working Load Limit		
	10:1	7:1	5:1
AC6 wall bracket	75lbs (333N)	107lbs (476N)	150lbs (667N)

These values have been confirmed with Finite Element Analysis

b. The weight/mass is listed as the following: AC6 Wall Bracket (10.3lbs, 4.7kg)

c. The AC6 Wall Mount bracket is designed to suspend only one loudspeaker per bracket.

d. Any geometric or structural modifications to the AC6 Wall Bracket or hardware are not EAW-approved will void the warranty and may result in damage, injury, or death.

e. **WARNING: Take care when lifting AC6 products to avoid harm or damage to product.**

f. **WARNING: AC6 Wall Brackets are for suspension of loudspeakers only. Suspension of persons is prohibited.**

AC6 User Manual

3. Installation of AC6 wall bracket to mounting surface

a. The wall bracket must be mounted to secure structure sufficient to support the products weight. If you are unsure, please consult a qualified professional. **A minimum of two attachment points must be used, each point capable of supporting 350lb (160kg) If four points are to be used, each point can be rated at 175lb (80kg)**

b. Mark the wall or structure where brackets will be mounted. Refer to the included customer drawing (2071359-CD) for mounting pattern. Use the points that provide the highest amount of vertical spacing.

c. If multiple columns are being mounted, spacing should be 39.0" (990.6mm) from centerline to centerline. This can be measured from bracket top to bracket top.

d. Product is designed for vertical mounting only. Use of level is encouraged to ensure bracket is vertical, and adjacent brackets align correctly when multiple speakers are mounted.

e. Ensure the bracket is in the correct orientation. The tabs will face the intended pan direction. Use of a level is encouraged to ensure bracket is vertical.

f. Secure the bracket to the wall with minimum of two hardware points. Each point must be capable of supporting 350 lbs. If four points are to be used, each point can be rated at 175 lbs.

Note: For mounting to wooden studs, the below points must be used. Install 1/4" x 3"lg 18-8 SS lag screw or M6 x 80mm lg 18-8 SS lag screw with flat washers. Mounting to metal studs is not recommend.



Detail: Two-point wooden stud installation

AC6 User Manual

4. Installation of cabinet bracket to the AC6 unit

- a. Using the desired cabinet orientation (input on bottom, or top), and desired pan direction (left or right) identify which side of the cabinet to mount the bracket.
- b. The bracket must be mounted on the side in which the pan is required. The bracket will not pan the opposite direction. For symmetrical L/R setups, the bracket will mount in mirror fashion.
- c. Locate the flytrack studs attached to the bracket inside the flytrack on the back of the cabinet. The two locating brackets on the outside of the bracket should sit inside the flytrack ridges.

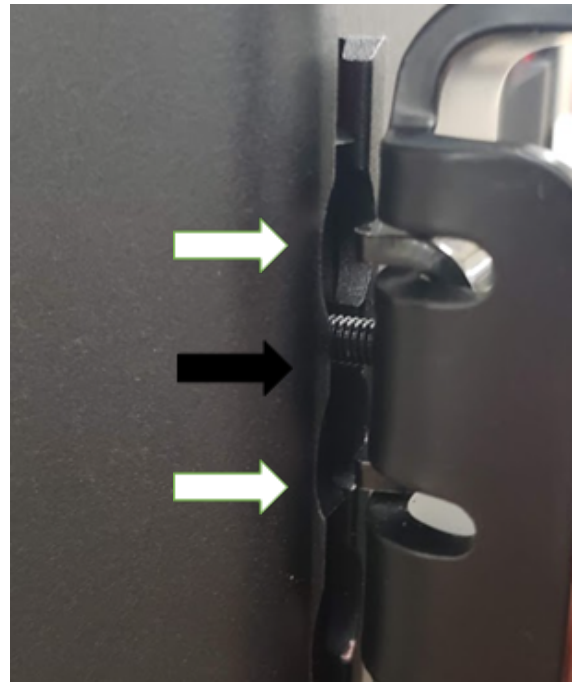

Detail: Flytrack studs and locating brackets



- d. Using 10mm wrench or hex driver, tighten the lock nuts on the flytrack studs to secure the bracket to the cabinet. Do not overtighten. (see image to left)
- e. The pan locking arm can be moved to the opposite side of the bracket if needed for improved tool access.

AC6 User Manual

5. Installation of AC6 to wall bracket

- a. Before mounting the AC6, wires should be run to the intended locations. Consider the orientation of mounting, power will either come from the top down, or the bottom up.
- b. Network, analog audio, and dry contacts can be looped from either end. Refer to user manual for more information.
- c. Starting from the bottom of the array and moving to the top, mount each AC6 to the respective wall bracket.
- d. The button head screws (M6x35) on the cabinet bracket are loose, it will be tightened once the cabinet is mounted to the wall bracket. Have a 4mm allen driver available to tighten immediately. **The cabinet should not be left unattended if this hardware has not been tightened.**

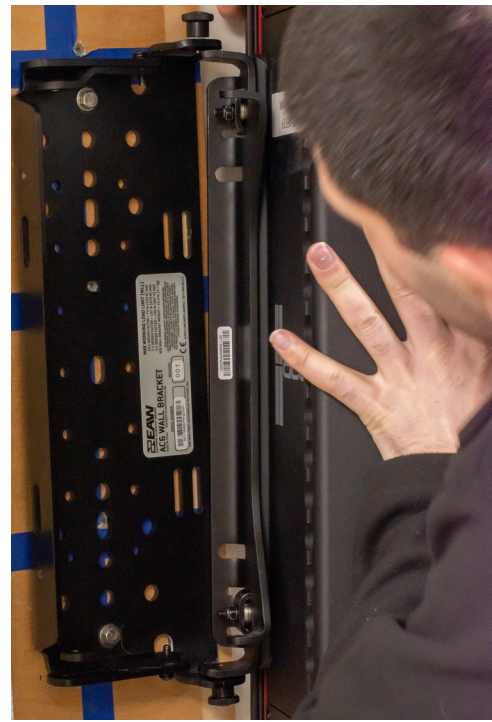

Attaching AC6 to wall bracket

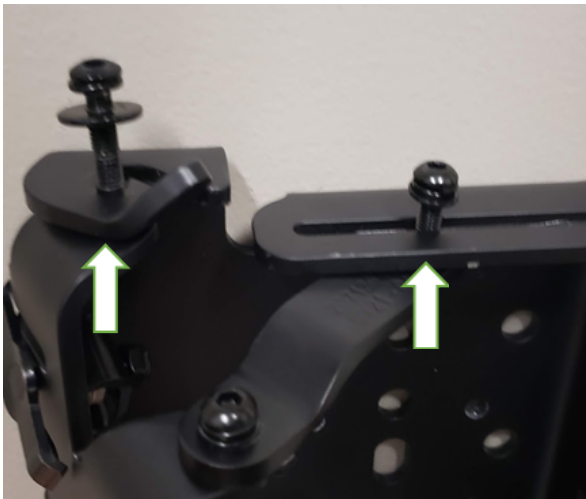

Detail: button head hardware positioning

- e. Lift the cabinet up to the mounting bracket and slide the M6x20 button head screw shafts into the notches in the wall bracket. Slide the cabinet back so the hardware sits fully into the notches.
- f. Using 4mm allen, fully tighten the M6x20 button head screws so the cabinet cannot be removed from the mount.
- g. Unscrew the button head (M6x20) screw from the pan locking arm and loosely attach the pan locking to the wall bracket.

AC6 User Manual

6. Cable the unit and set desired angle

- a. Using pre-wired cabling, wire the AC6 unit in both upper and lower locations.
- b. If WP covers are being used, install the covers at this stage.
- c. If additional cabinets are being mounted, repeat steps 5 and 6 until all units within an array are mounted.
- d. Rotate each cabinet in the array to the desired angle.
- e. Fully tighten hinge hardware and the pan lock to secure the cabinet in place. Do not overtighten.
- f. Mount the cosmetic cover (optional). Using the included M6x20 screws, attach the cover to the wall bracket to hide the hinge mechanism. Do not overtighten.

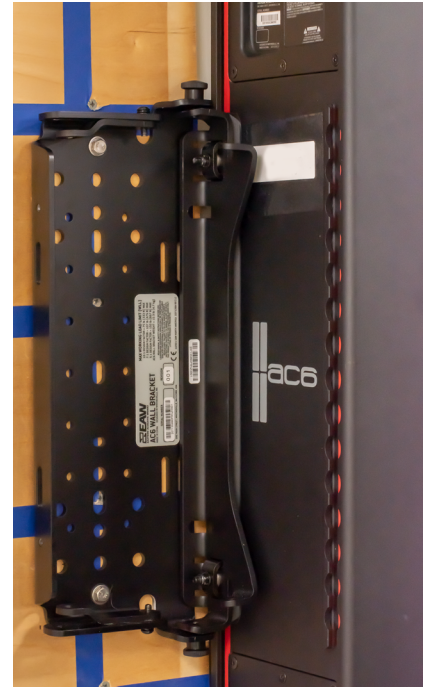

Panned wall bracket

Flush Mount Bracket Instructions

Tools needed: 10mm wrench or hex driver, 4mm allen

1. Inventory

Before beginning installation, inventory your available hardware to items listed.

Item	Description		Quantity
A	AC6 Wall Bracket		1
B	AC6 Cabinet Bracket Assembly		1
C	Cosmetic Cover		1
D	M6 x 20 screws		2

2. AC6 wall bracket limits of use

- a. The AC6 flush mount bracket is designed to suspend each corresponding AC6 Series loudspeaker with a design factor of 10:1 to meet or exceed most global suspension regulations. Below are the maximum working load limits at 10:1, 7:1 and 5:1 Design Factors.

AC6 User Manual

	Maximum Working Load Limit		
Design Factor	10:1	7:1	5:1
AC6 flush mount	75lbs (333N)	107lbs (476N)	150lbs (667N)

- b. The weight/mass is listed as the following: AC6 Flush Mount Bracket (10.3lbs, 4.7kg)
- c. The AC6 Flush Mount bracket is designed to suspend only one loudspeaker per bracket.
- d. Any geometric or structural modifications to the AC6 Flush Mount Bracket or hardware are not EAW-approved will void the warranty and may result in damage, injury, or death.
- e. **WARNING: Take care when lifting AC6 products to avoid harm or damage to product.**
- f. **WARNING: AC6 Flush Mount Brackets are for suspension of loudspeakers only. Suspension of persons is prohibited.**

3. Installation of AC6 flush mount bracket to surface

- a. The wall bracket must be mounted to secure structure sufficient to support the products weight. If you are unsure, please consult a qualified professional. **A minimum of two attachment points must be used, each point capable of supporting 350lb (160kg) If four points are to be used, each point can be rated at 175lb (80kg)**
- b. Mark the wall or structure where brackets will be mounted. Refer to the included customer drawing (2071359-CD) for mounting pattern. Use the points that provide the highest amount of vertical spacing.
- c. If multiple columns are being mounted, spacing should be 39.0" (990.6mm) from centerline to centerline. This can be measured from bracket top to bracket top.
- d. Product is designed for vertical mounting only. Use of level is encouraged to ensure bracket is vertical, and adjacent brackets align correctly when multiple speakers are mounted.
- e. Ensure the bracket is in the correct orientation. The wall bracket can be installed in different orientations to slide the cabinet bracket from the top or from either side.
- f. Secure the bracket to the wall with minimum of two hardware points. Each point must be capable of supporting 350 lbs. If four points are to be used, each point can be rated at 175 lbs.

Note: For mounting to wooden studs, two of the below points must be used depending on orientation of the bracket. Install 1/4" x 3"lg 18-8 SS lag screw or M6 x 80mm lg 18-8 SS lag screw with flat washers. Mounting to metal studs is not recommend.



AC6 User Manual

4. Installation of cabinet bracket to the AC6 unit

- a. Using the desired cabinet orientation (input on bottom, or top), and desired mounting method (left, right, top) identify position of the bracket on AC6. Note position on flytrack as this will need to remain uniform for all AC6 in column.
- b. The bracket must be mounted in the orientation in which they should be connected. Either from the top or from the left or right side.
- c. Locate the flytrack studs attached to the bracket inside the flytrack on the back of the cabinet. The two locating brackets on the outside of the bracket should sit inside the flytrack ridges.



AC6 cabinet flush mount for top installation



In this orientation bracket would join left > right

- d. Using 10mm wrench or hex driver, tighten the lock nuts on the flytrack studs to secure the bracket to the cabinet. Do not overtighten. (see image to left)

AC6 User Manual

5. Installation of AC6 to wall bracket

- a. Before mounting the AC6, wires should be run to the intended locations. Consider the orientation of mounting, power will either come from the top down, or the bottom up.
- b. Network, analog audio, and dry contacts can be looped from either end. Refer to user manual for more information.
- c. Using pre-wired cabling, wire the AC6 unit in both upper and lower locations.
- d. If WP covers are being used, install the covers at this stage.
- e. Using two people, line up the flush wall mount to the AC6 bracket, then slide into place.
- f. The button head screws (M6x35) on the cabinet bracket are loose, it will be tightened once the cabinet is mounted to the wall bracket. Have a 4mm allen driver available to tighten immediately. **The cabinet should not be left unattended if this hardware has not been tightened.**
- g. Using 4mm allen, tighten the button head screws so the cabinet cannot be removed from the mount.
- h. . If additional cabinets are being mounted, repeat steps 5 and 6 until all units within an array are mounted.



Installed flush mount bracket

AC6 User Manual

Maintenance of an AC6 Bracket installation

- a. **WARNING: Not following Maintenance instructions could result in equipment damage, serious injury or death.**
- b. Maintenance should only be performed by an experienced technician.
- c. As with any professional loudspeaker system, routine maintenance must be conducted in order to ensure the longevity and safe, consistent performance.
- d. Inspect the AC6 Wall Bracket for corrosion and other damage. Brackets with visible damage should be replaced and discarded.
- e. Inspect hardware securing the u-bracket to the mounting surface for corrosion or looseness. Tighten loose hardware and consider installing hardware locking methods. Replace and discard corroded hardware.
- f. Inspect hardware mounting the AC6 loudspeaker to the bracket for corrosion or looseness. Tighten loose hardware. Replace and discard corroded hardware.
- g. For weather protected applications (using WP Covers), inspect hardware sealants for cracking or gaps in sealant. Replace damaged sealant with user-supplied, waterproof, non-hardening, non-locking sealant per the sealant's instructions. Failure to do so could result in water ingress and damage to the loudspeaker.
- h. Clean the AC6 Wall Bracket and AC6 Loudspeaker with a dry cloth.

AC6 User Manual

Stinger Instructions

Inventory your kit

Part #	Part Name	Quantity	Reference
2071927-9999	PLATE LOCKING ASSY	1	A
2071924	M5X20 FLH SKT SS BLK	7	B
2071918-9999	Slide Plate	1	C
2072045-9999	Stinger Mount	2	D
2072041-9999	Stinger	2	E
2071404-9999	Mohawk	1	F

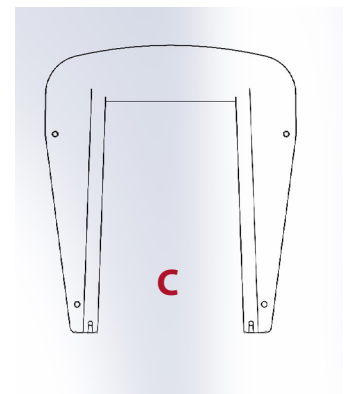
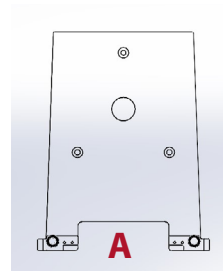
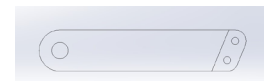
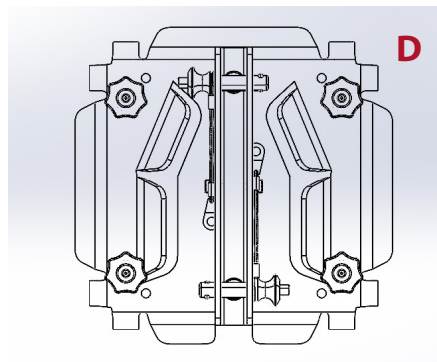
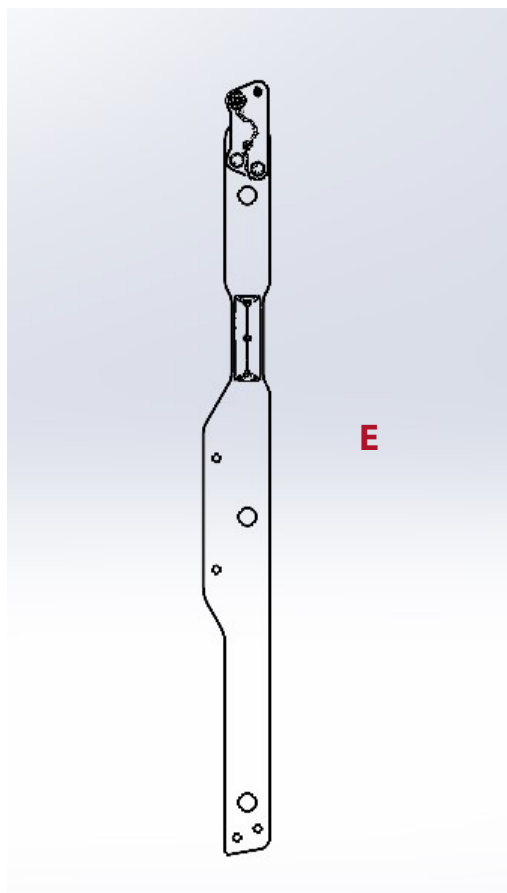

AC6 User Manual

Prepare AC6 for Stacking

1. Attach Locking Plate (A) to the top of the first AC6
 - Remove 3x M5x12mm screws from top of AC6 (Figure 1).
 - Position Locking Plate over open holes, then use 3x screws (B) to secure plate to the cabinet (Figure 2)

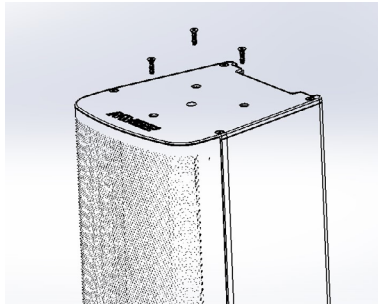

Figure 1 - Remove screws

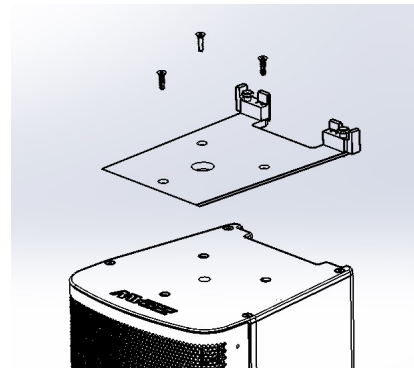

Figure 2 - Install Locking Plate

2. Attach slide plate (C) to bottom of next AC6
 - Remove 4x M5x12mm screws from bottom of AC6 (Figure 3).
 - Position Slide Plate over open holes, then use 4x screws (B) to secure plate to the cabinet (Figure 4)

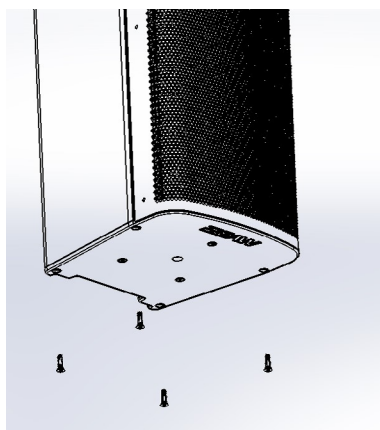

Figure 3 - Remove screws

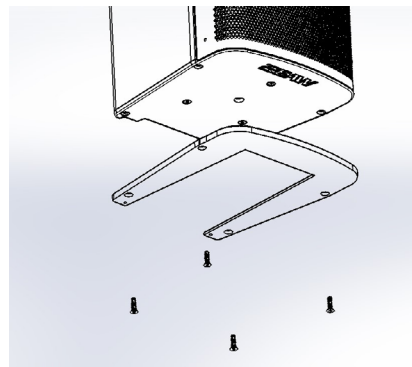

Figure 4 - Install Slide Plate

AC6 User Manual

Connect two AC6 Column loudspeakers with stacking plates

3. Attach two AC6 columns

- Slowly lay down AC6 with slide plate grill down on a rug or blanket
- Insert next unit with locking plate to connect (Figure 5)
- On rear of first AC6 locking plate, rotate both screw knobs clockwise to lock into position.

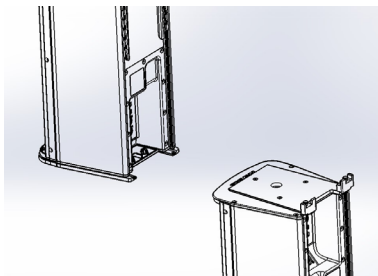

Figure 5 - Attach AC6 columns

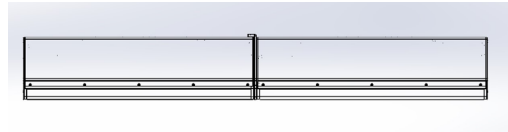

Figure 6 - AC6 columns grill down

Attach Stinger to AC6 Array

4. Attach Stinger Mounts (D) to AC6

- Center the mount on the Flytracks for each AC6 (Figure 6)
- Turn the knobs on the mount clockwise to lock into place.

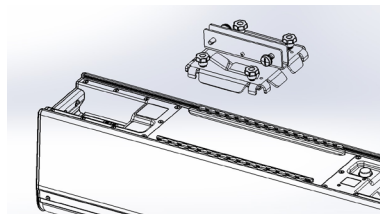

Figure 7 - Position Mount

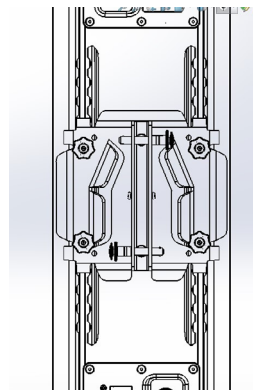

Figure 8 - Stinger Mount attached

AC6 User Manual

5. Attach Stinger (E) to Mounts

- Place stingers in place on the mounts (Figure 9)
- Use supplied pins to secure the two stingers together
- Using pins on mount, secure stinger assembly to mount plates (Figure 10)

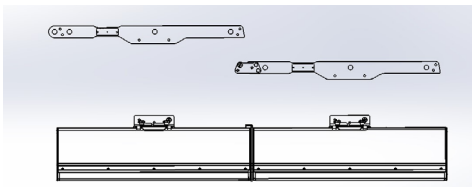

Figure 9 - Position Stingers on mounts

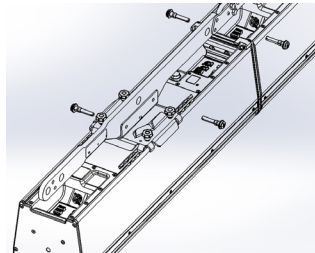

Figure 10 - Pin stinger assembly to mount plate

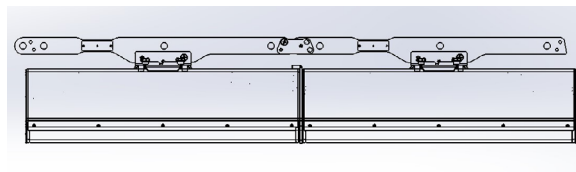

Figure 11 - Stingers assembled with AC6 array

6. Attach Mohawk (F) and suspend/fly array

- Attach Mohawk with pins at the end of the stinger (Figure 12)
- Once all pins and knobs are verified as secure, suspend array using a shackle.

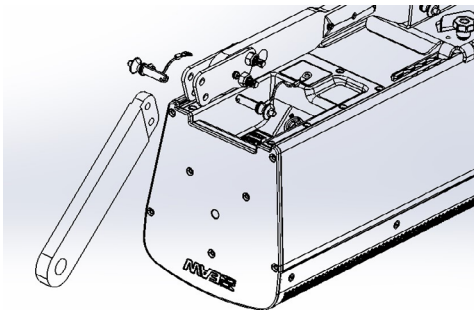

Figure 12 - Attach Mohawk to Stinger

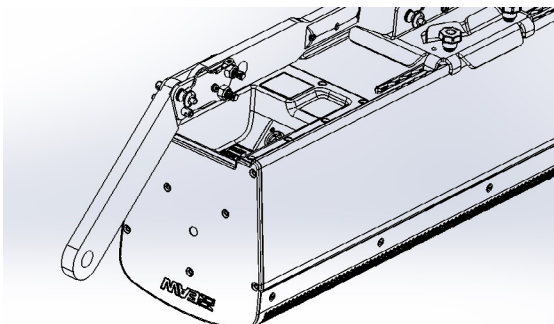

Figure 13 - Mohawk installed on Stinger

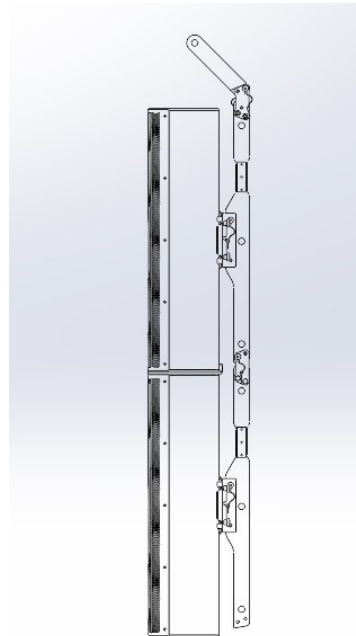

Figure 14 - Completed Stinger Array

AC6 User Manual

Stacking Plate Instructions

Inventory your kit

Part #	Part Name	Quantity	Reference
2071927-9999	PLATE LOCKING ASSY	1	A
2071924	M5X20 FLH SKT SS BLK - Use w/Reference A	3 per assembly	B
2071924	M5X20 FLH SKT SS BLK	4 per plate	B
2071918-9999	Slide Plate	2	C
2071929-9999	MOUNT PLATE ASSY AC6	1	D
2071920	SCREW M20X40 HHCS SS BLK OX	1	E
2071922	WASHER CURVED LOCK M20X34mm	1	F
2071923	WASHER FLAT M20 X 60mm OD SS BLK OX	1	G
0022095	SCREW M6 X 55 SHCS BLK	4 per assembly	H
105059	WASHER SPLIT-LOCK M6 SS BLK	4 per assembly	I
2071921	WASHER FLAT M6 X18mm OD SS BLK OX	4 per assembly	J

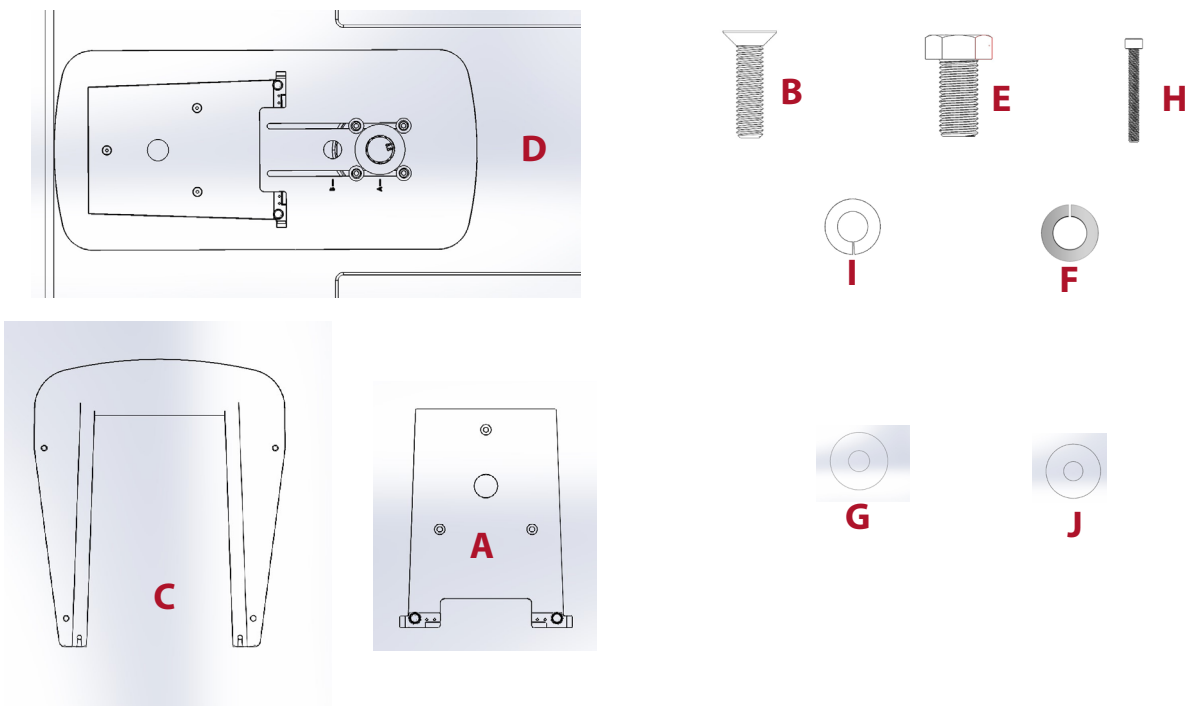

AC6 User Manual

Required Tools & Supplies

- M3 Allen Wrench
- M4 Allen Wrench
- 30mm Wrench

Prepare AC6 for Stacking

1. Attach Locking Plate (A) to the top of the first AC6 (If using with subwoofer mount plate, follow instructions in step 2 to attach slide plate to bottom of first AC6)

- Remove 3x M5x12mm screws from top of AC6 (Figure 1).
- Position Locking Plate over open holes, then use screws (B) to secure plate to the cabinet (Figure 2)

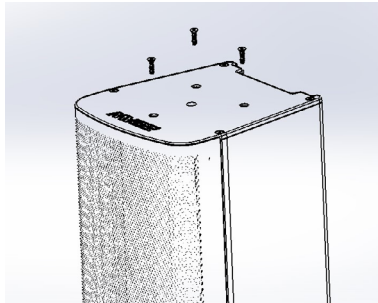

Figure 1 - Remove screws

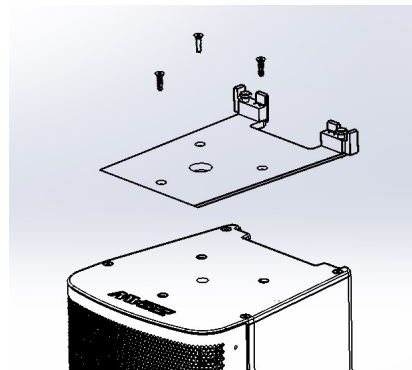

Figure 2 - Install Locking Plate

2. Attach slide plate (C) to bottom of next AC6

- Remove 4x M5x12mm screws from bottom of AC6 (Figure 3).
- Position Slide Plate over open holes, then use screws (B) to secure plate to the cabinet (Figure 4)

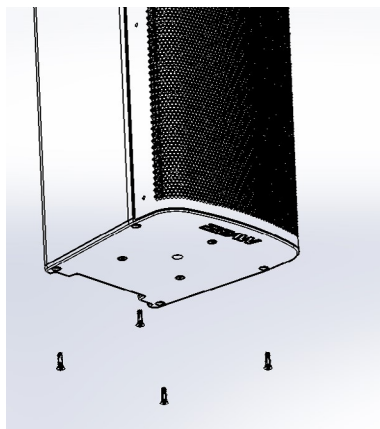

Figure 3 - Remove screws

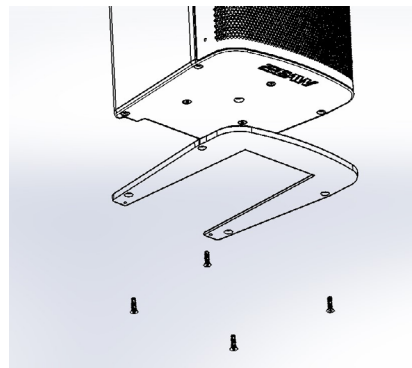

Figure 4 - Install Slide Plate

AC6 User Manual

Prepare Subwoofer Mount Plate for Stacking (if applicable)

3. Attach Mount Plate (D) to the top of SBX218/SBX118/RSX18F (Figure 5)

- Remove M6x35mm screws from subwoofer pole mount.
- Place Mount Plate on top of subwoofer, aligning hole **A** with pole cup.
- Lock into place with M6 screws (H), lock washer (I) and flat washer (J)
- Secure mount with M20 Screw (E), lock washer (F) and flat washer (G)

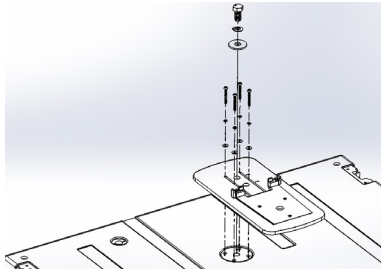

Figure 5 - Attach Mount Plate

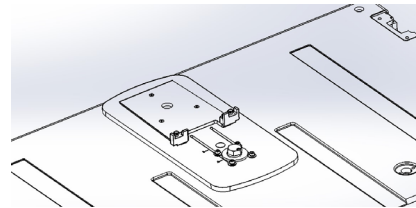

Figure 6 - Mount Plate installed

Configure AC6 Column on Subwoofer Mount Plate

4. Attach first AC6 to Subwoofer with mount plate

- Using two people, lift AC6 and line up bottom slide plate with subwoofer mount plate
- Slide into place (Figure 7). An audible clicking sound may be heard if pins are not in up position.
- On rear of mount plate, rotate both pin knobs clockwise to lock into position.

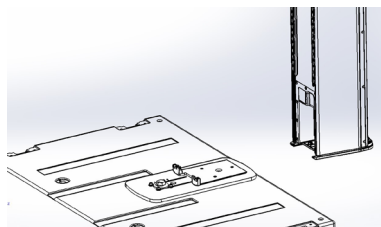

Figure 7 - Slide first AC6 to mount plate

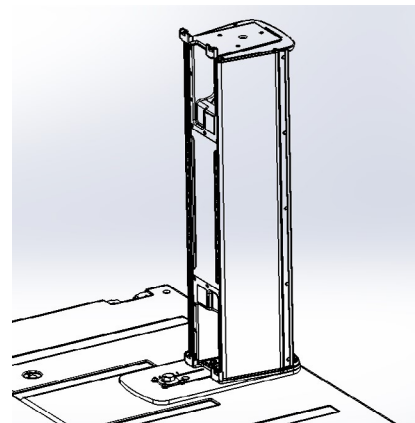

Figure 8 - AC6 Installed on mount plate

AC6 User Manual

Connect two AC6 Column loudspeakers with stacking plates

5. Attach two AC6 columns (Procedure is the same whether using Subwoofer Mounting Plate or not)

- Ensure first AC6 (bottom position) is standing flat on a surface or locked into place with the subwoofer mounting plate.
- If connecting a second AC6 on a subwoofer stack, using two steady ladders and two people, lift second AC6 and line up slide plate with the first AC6 locking plate.
- If connecting the second AC6 to first AC6 without utilizing the subwoofer mount plate, a ladder may not be needed. Still using two people, position second AC6 slide plate to line up with first AC6 locking plate.
- Slowly slide into plate until an audible click is heard. (Figure 9)
- On rear of first AC6 locking plate, rotate both screw knobs clockwise to lock into position.
- When using subwoofer mounting plate, only two AC6's are supported.

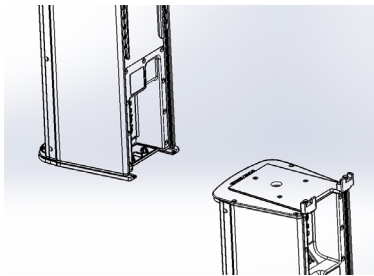

Figure 9 - Attach AC6 columns

AC6 User Manual

Pole Mount Instructions

These instructions are for the various ways to install the AC6 pole mount kit. There are three available mounting options with this kit:

- Pole Mount installed with slide plate and screws as support
- Pole Mount with screws only
- Pole Mount with slide plate and no screws

PREPARATION

1. Confirm the configuration of the AC6 arrays:
 - Number and location of AC6 column arrays to be deployed
 - Location and quantity of audio, network, and power cabling needed
2. Ensure that speaker stands are rated to hold weight of AC6 (70lbs)

Inventory your kit

Part #	Part Name	Quantity	Reference
2072035-9999	ASSY POLE MOUNT PLATE	1	A
2071924	M5X20 FLH SKT SS BLK	4	B
2071918-9999	Slide Plate	1	C
2072040	SCREW M5X22 BH SS BLK ZC	3	D
0016417	WASHER LOCK M5 BLK	3	E
2071679	WASHER FLAT M5 SS BLK ZC	3	F

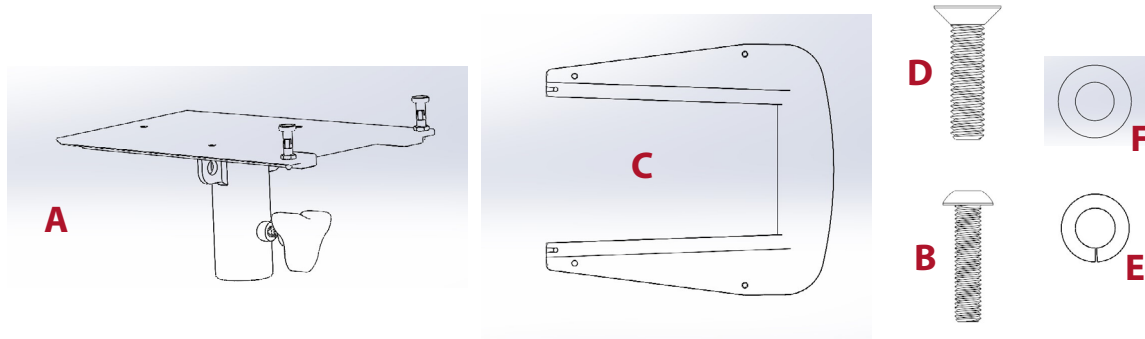

AC6 User Manual

Required Tools & Supplies

- 3mm Allen Wrench

Install Pole Mount with screws and slide plate

1. Attach slide plate to bottom of AC6

- Remove 4x M5x20 outer screws from bottom of AC6 for slide plate(Figure 1).
- Position Slide Plate over open holes, then use screws (B) to secure slide plate to the cabinet (Figure 2))
- Remove 3x M5x20 inner screws from bottom of AC6 for pole mount plate.

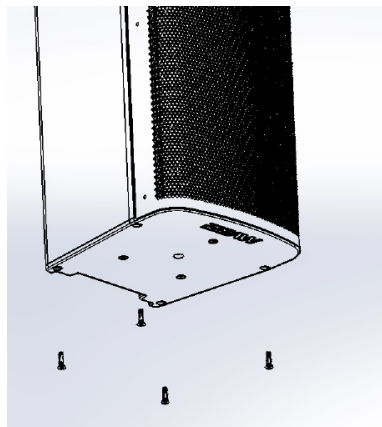

Figure 1 - Remove screws

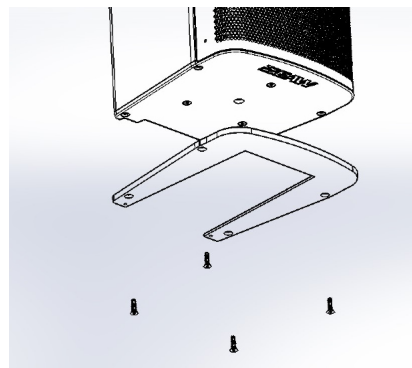

Figure 2 - Install Slide Plate

2. Slide Pole Mount Plate into Slide Plate (Figure 3)

3. Install flat washers (F), locking washers (E) and M5x22 screws (D) to secure Pole Mount Plate in place (Figure 4)

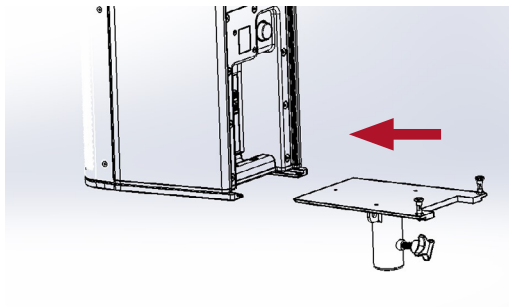

Figure 3 - Slide Pole Mount into place

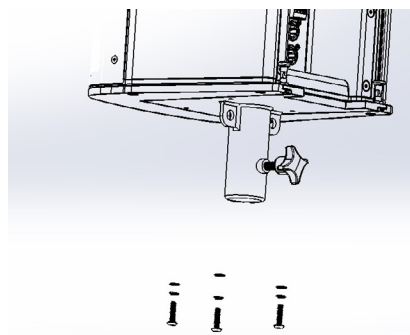

Figure 4 - secure screws and washers to Pole Mount & Cabinet

AC6 User Manual

Install Pole Mount with screws and **NO** slide plate

1. Attach Pole Mount to bottom of AC6

- Remove 3x M5x20 inner screws from bottom of AC6 for pole mount plate.
- Position Pole Mount Plate on bottom of AC6 (Figure 5).
- Secure plate into place using M5X2 screws (D), lock washer (E), and flat washer (F) (Figure 6)

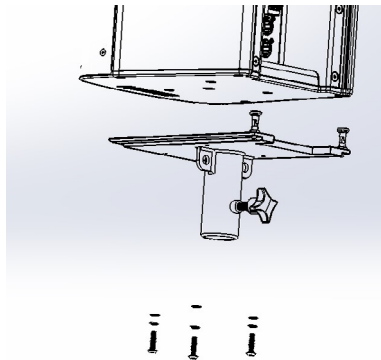

Figure 5 - Position Pole Mount Plate

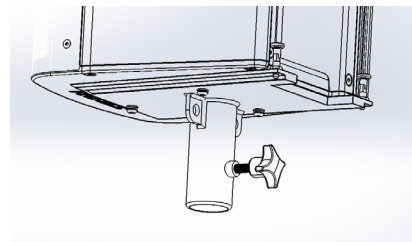

Figure 6 - Pole Mount, No slide plate

Install Pole Mount with **NO** screws and slide plate only

1. Attach slide plate to bottom of AC6

- Remove 4x M5 screws from bottom of AC6 (Figure 7).
- Position Slide Plate over open holes, then use 4x M5x20 (B) to secure slide plate to the cabinet (Figure 8)

2. Slide Pole Mount Plate into Slide Plate (Figure 9)

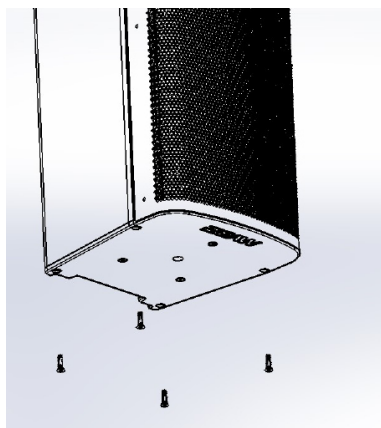

Figure 7 - Remove screws

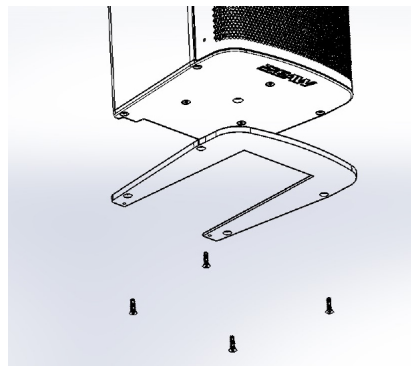

Figure 8 - Install Slide Plate

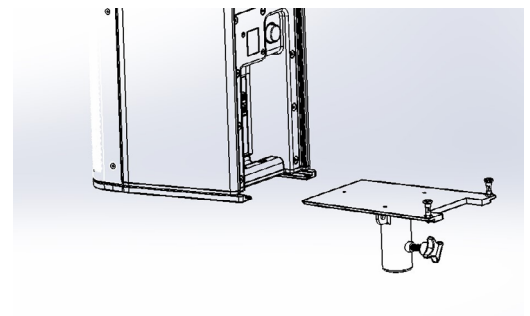

Figure 9 - Slide Pole Mount into place

AC6 User Manual

Installing Weather Protection Covers

Be sure to reference the installation instructions for the mounting solution, since the sequence may vary depending on how the array will be suspended.

NOTE: Instructions must be followed completely to ensure water tight seal. Failure to properly install weather protection covers could result in premature product failure and/or void the warranty.

Preparation

1. Confirm the configuration of the AC6 arrays:
 - Number of AC6 modules
 - Location and quantity of audio, network, and power cabling. One end of each cable must be left unterminated to pass through the knockouts.
 - Identify if covers will be fitted before or after mounting (refer to mount instructions)
2. Based on the quantity of AC6 modules determine the quantity of covers required:
 - 2X End Cover – (1) per array
 - Joint Cover – One less than number of speakers in array [i.e. (2) for (3) speakers]



WARNING: Installation should only be done by an experienced technician. Wear safety glasses and take proper safety precautions when using tools.

Inventory your kit

End Cover (each kit)

Qty	Description
2	Input Cover
2	Input Cover Gasket
18	M5 x 18 Buttonhead Head Allen Drive Screws
3	3/4" Gland Nuts



AC6 User Manual

Joint Cover (each kit)

Qty	Description
1	Input Joint Cover
1	Input Joint Cover Gasket
1	Joint Gasket
18	M5 x 18 Buttonhead Head Allen Drive Screws
3	3/4" Gland Nuts



Required Tools & Supplies

- 3mm Allen Wrench
- Flat head screw driver
- Mallet or Hammer
- Torque Driver (with 3mm Hex/Allen bit)
- Thread locker, Medium Strength - Loctite 242, Herson 423, or equivalent.

Remove cable knock outs (as needed)

- Place a flat head screwdriver into the slot of a 3/4" knockout that is to be removed.
- Hit the end of the screw driver to shear the knockout and remove the rest of the knockout by hand if necessary.
- If burrs remain, remove them with a countersink or deburring tool.



Note: 1/2" knockout size is for reference only and must be drilled out.

- To make the connection water tight, a 3/4" (or 1/2" as needed) gland nut (included), rigid conduit adapter or flexible conduit adapter (not included) should be fitted to each knockout prior to installing cables.
- Silicone sealant should be used as needed to make any cable connections water tight.